

# **BRUKER**

## **NMR Magnet System**

**UltraShield™ NMR Magnet System**  
**Magnet Manual**

**Version 001**

---

**BRUKER Magnetics**

---

The information in this manual may be altered without notice.

BRUKER Magnetics accepts no responsibility for actions taken as a result of use of this manual. BRUKER Magnetics accepts no liability for any mistakes contained in the manual, leading to coincidental damage, whether during installation or operation of the instrument. Unauthorised reproduction of manual contents, without written permission from the publishers, or translation into another language, either in full or in part, is forbidden.

This manual was written by

Joerg Arnold  
magnetics@bruker.ch

© 01.10.1998: BRUKER Magnetics AG

CH-8117 Faellanden, Switzerland

P/N: Z31242  
DWG-Nr: 913007

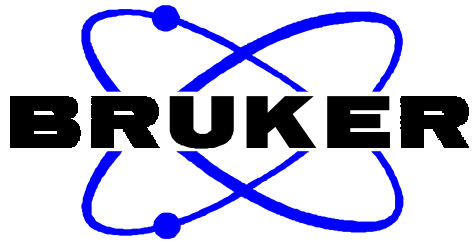

**BRUKER Magnetics**

Low Loss Cryostats

Superconducting Magnets

phone: ++41 1 825 91 11

fax: ++41 1 825 92 15

e-mail: [magnetics@bruker.ch](mailto:magnetics@bruker.ch)

[service@magnetics.bruker.ch](mailto:service@magnetics.bruker.ch)

[sales@magnetics.bruker.ch](mailto:sales@magnetics.bruker.ch)

**SUPERCONDUCTING  
ULTRASHIELD™  
NMR MAGNET SYSTEM**  
Coil Number BZH fff/ddv  
Dewar Number D xxx/ddd



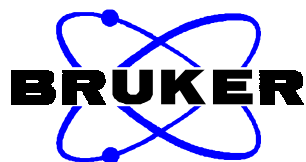

**Konformitätserklärung  
Declaration of Conformity  
Déclaration de Conformité  
Declarazione di Conformità  
Declaración de Conformidad**

Wir, We, Nous, Noi, Nosotros,

**BRUKER AG**

**Industriestrasse, 26  
CH - 8117 FAELLANDEN**

**Tel. ++41 / 1 / 825 9111  
Fax. ++41 / 1 / 825 9696**

erklären in alleiniger Verantwortung, dass das Magnetsystem  
declare under our sole responsibility that the magnet system  
déclarons sous notre seule responsabilité que le système magnétique  
dichiariamo in nostra unica responsabilità che questo sistema magnetico  
declaramos que de nuestra única responsabilidad ésta sistema magnético

**Coil Number BZH fff/ddv  
Dewar Number D xxx/ddd**

auf das sich diese Erklärung bezieht, mit den folgenden Richtlinien und Normen übereinstimmt:

to which this declaration relates, is in conformity with the following standards or other normative documents:

auquel se réfère cette déclaration, est conforme aux normes ou autres documents normatifs:

su quale si riferisce questa dichiarazione, e conforme alle norme o altri documenti normativi:

a lo que ésta declaración se refiere, y conforme a las normas u otros documentos normativos:

**89/392/EWG, 91/368/EWG, 93/44/EWG, SN EN 292/1995**

CH - 8117 Fällanden, 20.09.1998

.....  
Dr. R. Jeker, director

.....  
O. Schett, director

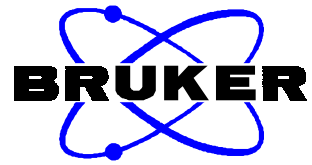

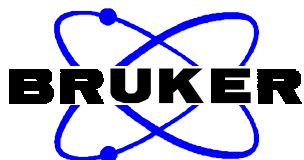

---

<b>Konformitätserklärung</b>	
<b>Declaration of Conformity</b>	
<b>Déclaration de Conformité</b>	
<b>Declarazione di Conformità</b>	
<b>Declaración de Conformidad</b>	<b>1</b>
<b>1 Safety Notes</b>	<b>1.1</b>
1.1 Introduction	1.1
1.2 The Magnetic Field	1.2
1.3 The safe handling of Cryogenic Substances	1.3
1.4 The safe operation of an UltraShield™ superconducting NMR Magnet System: Refill of liquid nitrogen and liquid helium	1.7
1.5 General Properties of Cryogenic Substances	1.9
1.5 Table of Properties of Cryogenic Substances	1.10
<b>2 Important Notes</b>	<b>2.1</b>
2.1 Important Notes	2.1
2.2 Hazards	2.1
2.3 Cryostat Installation	2.2
2.4 Handling of UltraShield™ superconducting NMR Magnet Systems	2.2
2.5 Special NMR Experiments	2.3
2.6 Discharging and Warming Up of the UltraShield™ NMR Magnet System	2.4
<b>3 Superconducting UltraShield™ NMR Magnet</b>	<b>3.1</b>
3.1 Characteristic Data	3.1
3.2 Resistance Measurements	3.2
3.3 Cool down Data	3.3
3.4 Charging Rates	3.5
3.5 Cycling of Shims and Shimmiing	3.6
3.6 Replacing the main current lead with the 32 pin main shorting plug	3.8
3.7 Replacing the shim current lead with the 32 pin shim shorting plug	3.8
3.8 Standard operation	3.9
3.9 Replacing the 32 pin main shorting plug with the main current lead	3.9
3.10 Replacing the 32 pin shim shorting plug with the shim current lead	3.10
3.11 Discharging Rates	3.11

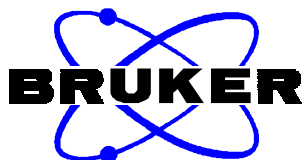

---

<b>4 Long Hold Cryostat</b>		<b>4.12</b>
4.1 Cryostat Installation	Dewar xxx/dd	4.12
4.2 Preparation of Disassembly of the Transport Fixture		4.13
4.3 Disassembly of the Transport Fixture		4.13
4.4 Preparation of Disassembly of the Transport Fixture at Low Ceiling Heights		4.13
4.5 Disassembly of the Transport Fixture at Low Ceiling Heights		4.14
4.6 Disassembly of the Transport Fixture of the Nitrogen Vessel		4.14
4.7 Assembly of the Transport Fixture		4.14
4.8 Assembly of the Transport Fixture of the Nitrogen Vessel		4.15
4.9 Alignment of the N2 Vessel and the Outer Vacuum Chamber (OVC)		4.16
4.10 Alignment of the Helium Vessel and the N2 Vessel	Dewar xxx/dd	4.16
4.11 Insertion and Alignment of the N2 Bore Tube and of the Room Temperature Bore Tube		4.17
4.12 Liquid Helium	Dewar xxx/dd	4.18
4.13 Liquid Nitrogen	Dewar xxx/dd	4.18
<b>5 Installation procedures for Bruker Cryostats</b>		
<b>Safe handling of Bruker NMR Magnet Systems</b>		<b>5.1</b>
5.1 Assembly of the NMR magnet system		5.1
5.2 Pumping of the NMR magnet system		5.1
5.3 Preparing the NMR magnet system for the Cool Down Procedure		5.1
5.4 Cool down procedure with Automatic Cooling Device (ACD*)		5.2
5.5 Cool down without the Automatic Cooling Device		5.3
5.6 Cool down with liquid helium		5.4
5.7 Charging and Shimming		5.5
5.8 Discharging Procedure		5.7
5.9 Warm up procedure for Cryostats		5.8
5.10 Temperature Sensor PT100		5.10
5.11 Safety Recommendations in the High Field NMR Laboratory		5.11
5.12 Helium Transfer Line (optional)		5.13
5.13 Vacuum Valve KF40 and Drop Off Plate		5.14
5.14 Installation of the Vacuum Valve during Installation of a Magnet System		5.14
5.15 Vacuum Valve KF40 and Valve Operator Body (optional, installation kit only)		5.16
5.16 Vacuum Valve KF40: Operation of the Sealing Plug		5.17
5.17 Operation of the Vacuum Valve KF40 to Pump an Evacuated Dewar		5.18
5.18 Breaking the Vacuum		5.19
5.19 Vacuum Valve KF25 and Drop Off Plate		5.21
5.20 Installation of the Vacuum Valve KF25 during Installation of a Magnet System		5.22
5.21 Vacuum Valve KF25 Diagram		5.23
5.22 Operation of the Vacuum Valve KF25 to Pump an Evacuated Dewar		5.24
5.23 Breaking the Vacuum		5.25



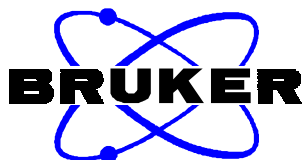

---

<b>6</b>	<b>Integrated Anti Vibration Stand</b>	<b>6.1</b>
6.1	Operation of the Anti Vibration Stand	6.1
6.2	Safe Operation of the Anti Vibration Magnet Stand	6.1
6.3	Moving the NMR Magnet System After Installation	6.2
6.4	Assembly of the Anti Vibration Stand	6.3
6.5	Adjustment of the Vibration Damping Columns	6.4
6.6	Function control of the Anti Vibration Magnet Stand	6.5
6.7	Disassembly of the Anti Vibration Magnet Stand	6.5
<b>7</b>	<b>Trouble Shooting</b>	<b>7.1</b>
7.1	Trouble shooting during Assembly	7.1
7.2	Trouble shooting during Cool Down Procedure	7.3
7.3	Trouble shooting during Charging and Shimming	7.8
7.4	Trouble shooting during Standard Operation	7.12
7.5	Trouble shooting during Discharging and Warm up	7.14
7.6	Trouble shooting of the Anti Vibration Magnet Stand	7.17
<b>8</b>	<b>Appendices</b>	<b>8.1</b>
8.1	Packing List	8.1
8.2	Options	8.1
8.3	Printed Forms	8.1

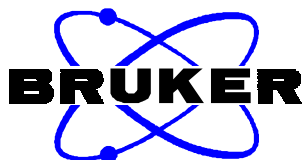

---

**Numerics**

22 pin shorting plug 5.5, 5.6  
32 pin main shorting plug 3.8  
32 pin shim current rod 3.3  
32 pin shim shorting plug 3.7, 3.8

**A**

Accessories 8.1  
Activated operation 6.1  
Adjusting screws 6.4  
After a quench 3.6, 5.7  
After ramping the magnet to field 1.3  
Alignment 6.4  
Alignment of the helium vessel and the N<sub>2</sub> vessel 4.16  
Alignment of the N<sub>2</sub> vessel and the outer vacuum chamber 4.16  
Assembly of the anti vibration stand 6.3  
Assembly of the NMR magnet system 5.1  
Assembly of the transport fixture 4.14  
Assembly of the vibration damping columns 6.4  
Attractive forces 2.1  
Automatic Cooling Device 3.3  
Auxiliary shorting plug 5.5

**B**

Baffle 3.8, 3.9  
Before cryoshimming 5.6  
Before ramping the magnet to field 1.3  
Before starting the cycling of the cryo shims 3.6  
Before starting the shimming procedure 3.7  
Boil off 1.7, 1.8  
Boil off rate 4.18  
Boiling point 1.10  
Break the vacuum 5.8, 5.20, 5.25  
Breaking the vacuum 2.2, 2.4, 5.19, 5.25  
Bursting disk 3.8

**C**

Cardiac pacemakers 2.1  
Central field 3.1  
Characteristic data 3.1  
Charging after cool down 5.5  
Charging cables 5.6  
Charging rates 3.5  
Charging record 3.5, 5.5, 8.1  
Charging table 5.5  
Charging time 3.5  
Checking the necks 1.8  
Coil inductance 3.1  
Condensing oxygen 1.6

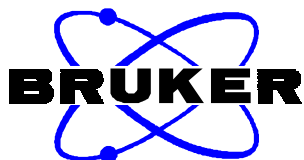

- 
- Connection lead for the ACD\* 3.3
  - Containers for cryogenic liquids 1.4
  - Control cable 5.6
  - Cool down data 3.3
  - Cool down procedure 5.2
  - Cool down with liquid helium 5.4
  - Cryo power supply 2.4, 5.6, 5.7
  - Cryo shim current 5.6
  - Cryo shimming 5.6
  - Cryogenic liquids 1.9
  - Cryogenic substances 1.9, 1.10
  - Cryogens 1.3
  - Cryostat installation 2.2, 4.12
  - Cryostat warm up 2.2
  - Current lead 5.5
  - Current polarity 3.8
  - Cycling of shims 2.3, 3.6
  - Cycling of shims and shimming 3.6
- D**
- Deactivated operation 6.1
  - Definitive place of operation 6.3
  - Difference between maximum and minimum allowed level 4.18
  - Disassembly of the bottom transport fixture 4.13, 4.14
  - Disassembly of the transport fixture of the nitrogen vessel 4.14, 4.15
  - Discharging procedure 5.7
  - Discharging rates 3.11
  - Discharging record 3.11
  - Discharging time 3.11
  - Discharging voltage 3.8
  - Drop off plate 5.14, 5.21
- E**
- Effective damping mechanisms 6.1
  - Electronic devices 2.1
  - Equipment 1.6
  - Excessive cooling losses 2.3
  - Experiments at the at extreme specified lowest and highest probe temperatures 2.3
  - Explosion hazard 1.3, 1.8
- F**
- Fast warm up 2.4
  - Fast warm up procedure 5.8
  - Ferromagnetic objects 5.11
  - Filling a warm container 1.5
  - Final pressure 5.1
  - First aid 1.5
  - Flush and pump 5.2, 5.3

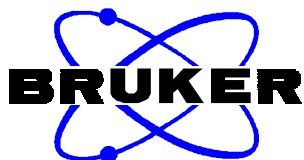

---

	Freezing of the O rings 1.7
	Function control 8.1
	Function control of the anti vibration magnet stand 6.5
<b>G</b>	
	Gas supply 6.1
	General safety rules 1.3
<b>H</b>	
	Handling of shielded superconducting magnets 2.2
	Handling of the helium transfer line 1.9
	Hazards 1.2
	Hazards associated 2.1
	Health hazards 1.5
	Heater Automatic 3.5, 3.11
	Helium boil off 8.1
	Helium level 1.8
	Helium level sensor 5.1
	Helium recovery system 2.2
	Helium transfer line 1.9, 5.13
	Helium transfer line with the extension piece 5.4
	Helium turrets 5.1
	Helium vessel 1.8
	High boil off 1.4
	High pressure containers for cryogenic liquids 1.3, 1.8
	High pressure transport containers for liquid nitrogen 1.6
	High temperature experiments 2.3
	High temperature gradients 3.3
	Hold time 4.18
<b>I</b>	
	Initial filling 4.18
	Insert the baffle 3.8, 3.9
	Inserting open ended pipes 1.5
	Insertion and alignment of the N2 bore tube and of the room temperature bore tube 4.17
	Installation of the vacuum valve during installation 5.14
	Installation of the vacuum valve KF25 during installation 5.22
	Installation procedures 5.1
	Internal diode 2.4, 3.8, 3.11
	Irreversible frequency shifts 2.3
<b>L</b>	
	Large coils 5.6
	Large spillage 1.4
	Liquid helium 1.6, 4.18
	Liquid nitrogen 1.6
	Low ceiling heights 4.13, 4.14
	Low temperature experiments 2.3

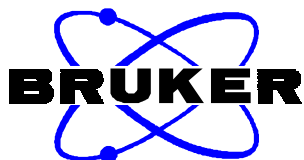
**M**

Magnet charging procedure 2.2  
Magnet current 3.1  
Magnet discharging procedure 2.4  
Magnet field forces 1.2  
Magnet shimming 2.3  
Magnet system warming up procedure 2.4  
Magnetic center 3.1  
Magnetic center from top flange 3.1  
Magnetic energy 3.1  
Magnetic field 1.2  
Magnetic stray field 5.11  
Main coil heater current 3.1  
Main current cable 5.6  
Main current lead 3.9  
Maximum allowed operation pressure 4.18  
Measuring of the helium level 1.8  
Mechanical platform 6.1  
Medical electronic implants 1.2  
Medical implants 1.2  
Minimum helium level 3.5  
Moving the NMR magnet system 6.2

**N**

Nitrogen boil off 8.1  
Nitrogen flow system 1.7, 5.2, 5.3, 5.4, 5.5  
Nitrogen security flow system 3.9  
Nitrogen vessel 1.7  
NMR system 2.1, 8.1

**O**

Once the vacuum is broken 5.9, 5.20, 5.25  
One way valve 5.5  
Operating the Shim Heater Automatic 5.6  
Operation of equipment 1.2  
Operation of the vacuum valve KF25 to pump an evacuated dewar 5.24  
Operation of the vacuum valve KF40 to pump an evacuated dewar 5.18  
Operation position 6.1  
Oscillation damper 3.9  
Overheated liquid gas 1.4  
Overshoot 3.5  
Oxygen shortage 1.5

**P**

Packing list 8.1  
Persistent mode 2.3, 3.6  
Pneumatics 6.4

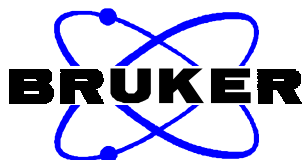

- 
- Precooling tube 5.2
  - Preparation of disassembly of the transport fixture 4.13
  - Preparing the NMR magnet system for the cool down procedure 5.1
  - Pressure dependence of the boiling temperature 1.4
  - Pressure loss 6.2
  - Protective clothing 1.5, 1.8
  - Proton frequency 3.1
  - PT100 5.10
  - PT100 temperature sensors 3.3
  - Pump and flush 5.4
  - Pump and flush the vacuum vessel 5.1
  - Pumping of the NMR magnet system 5.1
  - Pumping unit 5.2, 5.3, 5.4
- Q**
- Quench 1.10
  - Quench risks 2.2
  - Quench valves 5.1
- R**
- Radiation shields 2.2
  - Rapid transfer 1.7
  - Rapid warm up procedure 5.8
  - Reasons for precooling 3.3
  - Recool the magnet 5.7
  - Reference surface for the levelling 6.3, 6.4
  - Refill of liquid helium 1.8
  - Refill of liquid nitrogen 1.7
  - Refill record 8.1
  - Regulation rod 6.4
  - Regulation valves 6.4
  - Releasing overpressure 1.5
  - Replacing the 32 pin main shorting plug 3.9
  - Replacing the 32 pin shim shorting plug 3.10
  - Replacing the main current lead 3.8
  - Replacing the shim current lead 3.8
  - Resistance measurements 3.2
  - RT shim system angle 3.1
  - Run out of liquid helium and nitrogen 5.8
- S**
- Safety hazards 5.11
  - Safety recommendations 5.11
  - Save operation 6.1
  - Sealing plug 5.14, 5.17, 5.22
  - Self ignition 1.6
  - Shielding 2.1
  - Shim coil heater current 3.1
  - Shim current 3.1, 3.7

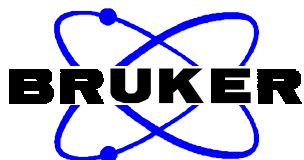

- 
- Shim current lead 3.7, 3.10
  - Shim heater 3.5, 3.11, 5.6
  - Shim Heater Automatic 5.6
  - Shimming 3.6
  - Shimming procedure 2.3
  - Shorting connector 5.6
  - Shorting plug 2.3, 3.6, 5.5
  - Smoking 1.6
  - Special 22 pin connection lead for the ACD\* 5.2
  - Special N2 blow out tube 5.8
  - Special NMR experiments 2.3
  - Specified hold time 1.8
  - Specified loss rates 2.2
  - Stray field 2.1, 5.18, 5.24
  - Strong oscillations 1.4
  - Super insulation 2.4
  - Supercooling 1.7
  - Syphon 1.9, 5.4, 5.8
- T**
- T emperature of liquid nitrogen 1.4
  - Temperature diagram 1.4
  - Temperature rise 1.4
  - The safe handling of cryogenic substances 1.3
  - Time between charging and shimming 3.6
  - Time between cool down and charging 3.3
  - Time constants 5.6
  - Training quenches 2.2
  - Transfer of liquid helium 1.9
  - Transfer of liquid nitrogen 1.8
  - Transfer pressure 1.8, 1.9
  - Transferring liquid nitrogen 1.5
  - Transport dewars 1.6
  - Transport fixture 5.1
- U**
- Ultra low loss cryostat 2.2
  - UltraShield superconducting NMR magnet system 2.1
  - Users manual for NMR magnet systems 1.1, 1.7
- V**
- Vacuum chamber of the cryostat 2.2
  - Vacuum insulated pipes 1.6
  - Vacuum valve 5.21, 5.23
  - Vacuum valve KF40 5.14, 5.16, 5.17
  - Valve operator body 5.14, 5.16, 5.18
  - Valve stem 5.15
  - Vaporisation 1.3
  - Very high boil off 1.4
-

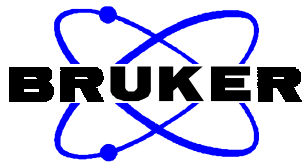

	Vibration damping 6.1
	Vibration damping columns 6.1
	Volume between maximum and minimum allowed level 4.18
	Volume x pressure 4.18
<b>W</b>	
	Warm up 5.9
	Warning areas 1.1
<b>Z</b>	
	Z and Z2 shim heaters 2.2, 2.4, 3.5, 3.11
	Z and Z2 shims 2.2
	Z2 shift 2.3
	Zeolith getter 4.16
	Zero reading of the helium level sensor 5.1, 5.4



---

## 1 Safety Notes

---

### 1.1 Introduction

---

**Read this first!**

Within this manual the Users Manual for NMR Magnet Systems is found in chapters 8 to 12 in english, german, french, italian and spanish. Please read it carefully and make it accessible to everybody working with the magnet system. An UltraShield™ superconducting NMR Magnet System can be operated easily and safely provided the correct procedures are obeyed and certain precautions observed.



**These notes must be read and understood by everyone who comes into contact with an UltraShield™ superconducting NMR Magnet System.** They are not for the sole information of senior or specialist staff. Proper training procedures must be undertaken to educate effectively all people concerned with such equipment with these requirements. Since the field of the NMR magnet system is three dimensional, consideration must be given to floors above and below the magnet as well as to the surrounding space at the same level.

**Warning areas**

The installation and operation of an UltraShield™ superconducting NMR magnet system presents a number of hazards of which all personnel must be aware. **It is essential that:**

- Areas in which NMR magnet systems are to be installed and operated, and the process of the installation generally, **are planned with full consideration for safety.**
- Such premises and installations are operated in a safe manner and in accordance with proper procedures.
- Adequate training is given to personnel.
- Clear notices are placed and maintained to effectively warn people that they are entering a hazardous area.
- All health and safety procedures are observed.

These notes outline aspects of operation and installation which are of particular importance. However, the recommendations given cannot cover every eventuality and if any doubt arises during the operation of the system the user is strongly advised to contact the supplier. It is the intention of Bruker's customers to communicate effectively the information in this manual regarding safety procedures and hazards associated with NMR magnet systems to their own customers and to users of the equipment.

## 1.2 The Magnetic Field



### Hazards

Certain precautions must be taken to ensure that hazards will not occur due to the effects of a magnetic field on magnetic materials or on surgical implants. Typical of such effects are the following:



### Magnet field forces

Large attractive forces may be exerted on equipment in proximity to the NMR magnet system. The force may become large enough to move the equipment uncontrollably towards the NMR magnet system. Small pieces of equipment may therefore become projectiles. Large equipment (e.g. gas bottles, power supplies) could cause bodies or limbs to become trapped between the equipment and the magnet. The closer to the NMR magnet system, the larger the force. The larger the equipment mass, the larger the force.



### Shielding

**Due to the very effective shielding of the superconducting coil, the effects of the magnetic stray field are minimized. Nevertheless keep in mind that directly above and directly below the magnet the stray field is very high and the attractive forces on magnetic items are very strong!**



### Medical electronic implants

**The operation of medical electronic implants, such as cardiac pacemakers, may be affected either by static or changing magnetic fields. Pacemakers do not all respond in the same way or at the same field strength if exposed to fields above 5 gauss.**



### Medical implants

**Other medical implants, such as aneurysm clips, surgical clips or prostheses, may contain ferromagnetic materials and therefore would be subject to strong attractive forces near to the NMR magnet system. This could result in injury or death. Additionally, in the vicinity of rapidly changing fields (e.g. pulsed gradient fields), eddy currents may be induced in the implant resulting in heat generation.**

### Operation of equipment

The operation of equipment may be directly affected by the presence of large magnetic fields. Items such as watches, tape recorders and cameras may be magnetised and irreparably damaged if exposed to fields above 10 gauss. Information encoded magnetically on credit cards and magnetic tapes may be irreversibly corrupted. Electrical transformers may become magnetically saturated in fields above 50 gauss. The safety characteristics of equipment may also be affected.

### Reading attentively

To prevent situations as described above to occur, the following general precautions are provided as guidelines. They should be regarded as minimum requirements. Every magnet site location should be reviewed individually to determine precautions to be taken against these hazards. Also, since the field of the NMR

---

	magnet system is three dimensional, consideration must be given to floors above and below the magnet as well as the surrounding space at the same level.
<b>Before ramping the magnet to field</b>	Ensure all loose ferromagnetic objects are removed from within 5 meters of the NMR magnet system. <ul style="list-style-type: none"><li>• Especially remove the pumping unit.</li><li>• Display illuminated warning signs that the NMR magnet system is operating at all points of access to the magnet room.</li><li>• Display warning signs giving notice of the possible presence of magnetic fields and of the potential hazards in all areas where the field may exceed 5 gauss.</li><li>• The safe working field level of other equipment must be individually assessed by the system manufacturer.</li></ul>
<b>After ramping the magnet to field</b>	Do not bring ferromagnetic objects into the magnet room. Use only nonmagnetic cylinders and dewars for storage and transfer of compressed gas or cryogenic liquids. Equipment for transportation of cylinders and dewars must also be non magnetic.

### 1.3 The safe handling of Cryogenic Substances

---

<b>Cryogenics</b>	Cryogenic liquids can be handled easily and safely provided certain precautions are obeyed. The recommendations in this section are by no means exhaustive and when in doubt the user is advised to consult the supplier. The safe handling of cryogenic liquids requires some knowledge of the physical properties of these liquids, common sense and sufficient understanding to predict the reactions of such liquids under certain physical conditions. The substances referred to in these recommendations are nitrogen, helium and air.
-------------------	--



<b>General safety rules</b>	Cryogenic liquids, even when kept in insulated storage vessels (dewar vessels), remain at a constant temperature by their respective boiling points and will gradually evaporate. The very large increase in volume accompanying the vaporization of the liquid into gas and the subsequent process of warming up is approximately 700:1 for helium and nitrogen and therefore:
-----------------------------	--



<b>Warning:</b>	<b>Do not use cryogenics that have been stored in high pressure containers for cryogenic liquids! If no other containers are available the pressure must be released completely before connecting the high pressure transport container to the cryostat. This would present an explosion hazard for the magnet system and could lead to severe damage!</b>
-----------------	--

---

**Temperature rise** The high pressure within high pressure transport containers leads to a large increase of the boiling temperature of the liquid gas. Transferring such overheated liquid gas into the low loss cryostat will result in very high boil off and strong oscillations until the liquid gas has cooled down to the boiling temperature at atmospheric pressure again!



**Temperature diagram** The pressure dependence of the boiling temperature and thus of the temperature of liquid nitrogen stored at a given pressure within a transport vessel is given in the diagram below. As soon as the pressure is released the liquid will start to boil off strongly and will reduce its temperature back to 77 K at atmospheric pressure.

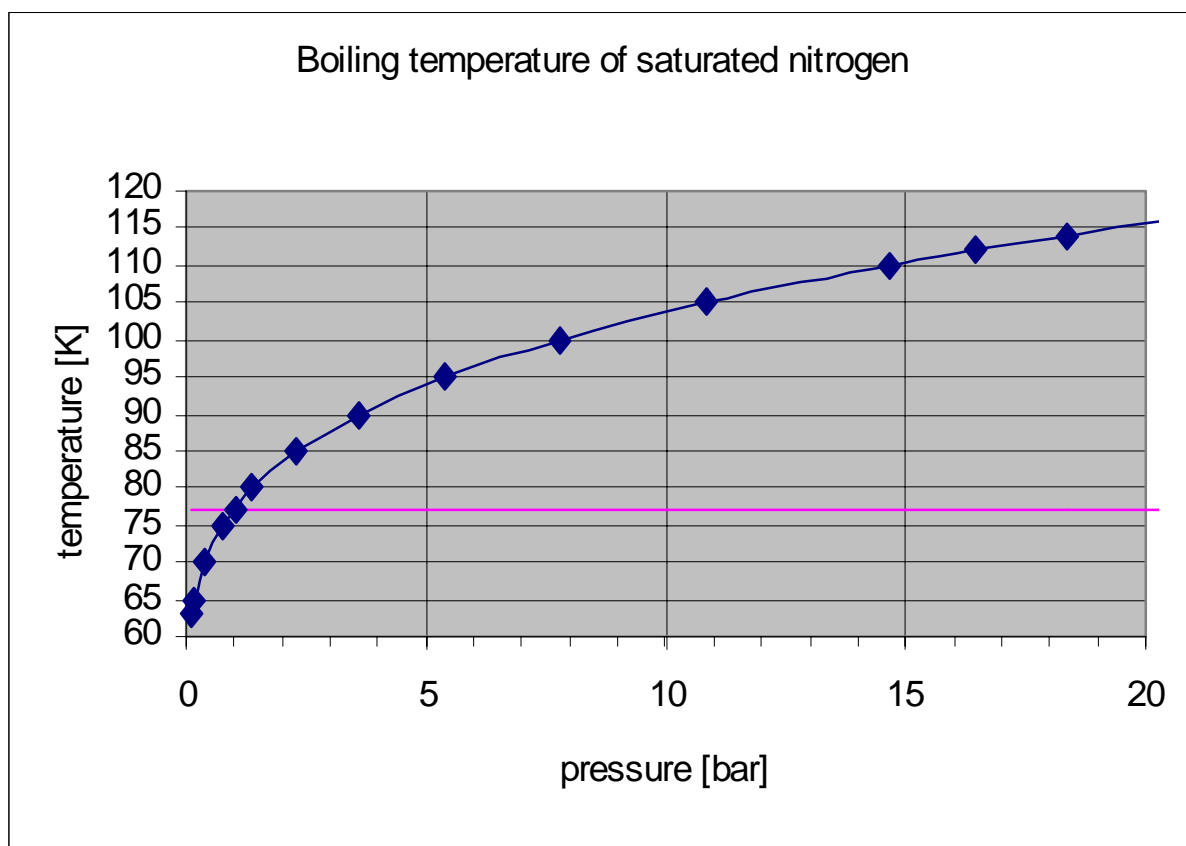

**Warning:** Containers for cryogenic liquids must not be closed completely as this would result in a large build up of pressure. This will present an explosion hazard and leads to large product losses!

In the event of a large spillage, immediately evacuate the area.

**Health hazards**

An oxygen shortage of varying severity may occur if the magnet room is not properly ventilated. Helium can displace air in the upper parts of a room and cold nitrogen can displace air in the lower parts.

Cryogenic substances in liquid or vapour form (or as low temperature gases) produce effects on the skin similar to burns (cold burns).

Exposed or insufficiently protected parts of the body coming into contact with uninsulated venting pipes or vessels (see ventilation section) will immediately stick and the flesh will be torn if the affected body part is removed.

**First aid**

If any of the cryogenic liquids come into contact with eyes or skin, immediately flood the affected area with large quantities of cold or tepid water and then apply cold compresses. Never use hot water or dry heat.

**Medical advice should be sought immediately.**

**Protective clothing**

Protective clothing must be worn mainly to avoid cold burns. Therefore dry leather or P.V.C gloves must be worn when handling or working with cryogenic liquids.

Gloves must be loose fitting so that they can be removed easily in case of liquid spillage.

Eyes must be protected by goggles.

Do not wear any metallic objects (e.g. jewellery) on those parts of the body which may come into contact with the liquid.

**Handling**

Cryogenic liquids must be handled and stored in well ventilated areas.

Do not allow cryogenic liquids to come into contact with the body.

Always handle the liquids carefully. Boiling and splashing will always occur when filling a warm container or releasing overpressure from a container.

Beware of liquid splashing and rapid flush off of helium when lowering equipment at ambient temperature into the liquid. This operation must be carried out very slowly.

When inserting open ended pipes into the liquid, block off the warm end until the cold end has cooled down, otherwise cold liquid may spurt out of the open end under self generated pressure. Never allow such pipes to point directly towards any person.

Use only metal or teflon tubing connected by flexible metal or teflon hose for transferring liquid nitrogen. Use only gum rubber or teflon tubing.



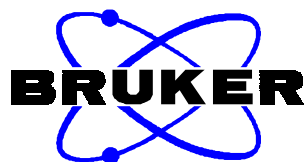

---

	<p>Do not use tygon or plastic tubing. They may split or shatter when cooled by the liquid flowing through it and could cause injury to personnel.</p>
<b>Equipment</b>	<p>Use only containers constructed of non magnetic materials and specifically designed for use with particular cryogenes. <b>We do not recommend the use of any high pressure transport containers for liquid nitrogen!</b></p>
<b>Liquid nitrogen</b>	<p><b>Good ventilation is essential.</b> Store and use in a well ventilated place. If sufficient gas evaporates from the liquid in an unventilated place (e.g. overnight in a closed room) the oxygen concentration in the air may become dangerously low. Unconsciousness may result suddenly without prior warning symptoms and may be fatal. For example, the evaporation of 40 litres of liquid nitrogen produces 27'000 litres (1'070 cubic feet) of nitrogen gas. If this vaporisation takes place in an unventilated room of 27m<sup>3</sup> (3m x 3m x 3m) (1'070 cubic feet = 10,2 ft x 10,2 ft x 10,2 ft) it can produce a very dangerous situation. Appropriate multiplication of these parameters will indicate actual site conditions.</p>
<b>Condensing oxygen</b>	<p><b>Minimise contact with air.</b> Since liquid nitrogen is colder than liquid oxygen, the oxygen in the air will condense out. If this happens for some time, the oxygen concentration in the liquid nitrogen may become so high that it becomes as dangerous to be handled as liquid oxygen. This applies particularly to wide necked dewars due to the large surface area. Therefore ensure that contact with air is kept to a minimum.</p>
 <b>Smoking</b>	<p><b>Do not smoke.</b> Rooms in which cryogenic liquids are being handled should be designated „No Smoking“ areas. While nitrogen and helium do not support combustion, their extreme cold can cause oxygen from the air to condense on cold surfaces and may increase the oxygen concentration locally. There is a particular fire danger if the cold surfaces are covered with oil or grease which are combustible. <b>Self ignition could occur!</b></p>
<b>Liquid helium</b>	<p><b>Liquid helium is the coldest of all cryogenic liquids. It will therefore condense and solidify any other gas (air) coming into contact with it. The consequent danger is, that pipes and vents may become blocked with frozen gas!</b></p> <p>Liquid helium must be kept in specially designed storage or transport dewars. Dewars should have a one way valve fitted in the helium neck at all times, in order to avoid air entering the neck and plugging it with ice. Vacuum insulated pipes should be used for liquid transfer. Breakdown of the insulation may give rise to the condensation of oxygen.</p> <p>Helium is inert.</p>

## 1.4 The safe operation of an UltraShield™ superconducting NMR Magnet System: Refill of liquid nitrogen and liquid helium



### Read this first!

Within this manual the Users Manual for NMR Magnet Systems is found in chapters 8 to 12 in english, german, french, italian and spanish.

**Please read it carefully and make it accessible to anybody working with the magnet system.** An UltraShield™ superconducting NMR Magnet System can be operated easily and safely provided the correct procedures are obeyed and certain precautions observed.

The recommendations in this section cannot cover every eventuality and if any doubt arises during the operation of the system, the user is strongly advised to contact the supplier.

### The nitrogen vessel

The nitrogen vessel should be checked daily for boil off and nitrogen level. These values should be recorded. If the boil off falls to zero, the necks should immediately be checked for the presence of ice as described below.

### Nitrogen flow system

A pressure relief valve is provided for the nitrogen vessel to ensure that at least the rear neck tube cannot be blocked by the ingress of air or moisture. **This valve should be mounted at all times even when the vessel is being refilled.**

In addition the other nitrogen necks should be checked for blockages after every refill of either nitrogen or helium. This can be done simply by inserting a brass or copper rod of 0,635 cm diameter into each neck in turn.



### Rapid transfer

During a rapid transfer of liquid helium, supercooling of the liquid nitrogen occurs. This can reduce the static boil off to zero and create a negative pressure in the nitrogen vessel. Thereby air or moisture could be sucked into the necks of the vessel, where it would solidify. Do not remove the nitrogen security flow system during any transfer liquid helium!

### Refill of liquid nitrogen

When the vessel is being refilled, liquid nitrogen should not be allowed to spill onto the room temperature bore closure flange. Put gum rubber tubes or teflon tubes on the nitrogen neck tubes during refill!

**The transfer should be stopped immediately when the vessel is full.**

Failure to observe this can lead to the freezing of the O rings and a subsequent vacuum loss of the NMR magnet system.



**Important Note:** Transfer of liquid nitrogen can be done easily and safely, provided the transfer pressure does not exceed 350 mbar (5 psi). Never apply a transfer pressure of more than 350 mbar (5 psi) to the nitrogen vessel and always make sure, that all nitrogen neck tubes are fully open!



**Warning:** Do not use cryogenics that have been stored in high pressure containers for cryogenic liquids! If no other containers are available the pressure must be released completely before connecting the high pressure transport container to the cryostat. This would present an explosion hazard for the magnet system and could lead to severe damage!

Protective clothing must be worn when handling liquid nitrogen. This includes dry leather or P.V.C. gloves to avoid cold burns and goggles for eye protection.

**The helium vessel** The helium vessel should be checked weekly for boil off and helium level. Use a helium flowmeter or a helium gas counter!

These values should be recorded. If the boil off falls to zero for a period greater than 24 hours, the neck tubes should be checked for the presence of ice. The procedure for checking the neck tubes and removing any blockage should be attempted only by a trained technician with considerable experience on cryogenic systems.



**Important:** Note that every measuring of the helium level incorporates some helium loss due to the heating of the level sensor. The specified hold time is guaranteed only when the helium level is measured once a week or less!

A one way valve is supplied to be mounted on the helium manifold to ensure that the helium neck tubes cannot be blocked by the ingress of air or moisture. This valve should be mounted at all times except during a helium transfer.



**Important:** Do not leave the helium manifold open to the atmosphere longer than 5 seconds unless a large gas flow is present!

**Refill of liquid helium** We recommend to refill the helium vessel within the specified hold time period and certainly before the level falls below the allowed minimum level (see chapters 3 and 4).



**Important Note:**

**Transfer of liquid helium can be done easily and safely, provided the handling of the helium transfer line is correct, the helium transfer line is not damaged and the transfer pressure does not exceed 350 mbar (5 psi).**

Never insert a warm helium transfer line into the cryostat, the warm helium gas could lead to a quench of the magnet! Always allow the helium transfer line to cool down to helium temperature before inserting it into the right helium neck tube. You should see liquid helium leaving of the short end transfer lines for a few moments, before inserting it into the right helium neck tube.

**Do not use extensions on the helium transfer line that will reach the syphon for refilling.**

**Important Note:**

Normally there is no extension needed for refilling. Only special transfer lines used at very low ceiling heights need an extension also during the refill process.

**Never apply a transfer pressure of more than 350 mbar (5 psi) to the helium vessel and always make sure, that the outlet of the helium manifold is fully open either to the atmosphere or to a helium recovery system.**

**Checks after refill of helium**

The O ring sealing the syphon entry port should be checked after every transfer. The helium vessel should never be left open to atmosphere for more than 5 seconds.

Check that there is a gas flow through the flow meter after the refill of helium.

Check that the nitrogen neck tubes are free of ice.

Check that after some time the nitrogen neck tubes become cool again. Ice or condensing moisture should be visible.

Protective clothing must be worn when handling liquid helium. This should include dry leather or P.V.C gloves to avoid cold burns and goggles for eye protection.

## 1.5 General Properties of Cryogenic Substances

**Cryogenic liquids**

Superconducting magnets use liquid nitrogen and liquid helium as cooling agents. These liquids expand their volume by a factor of 700 when they are evaporated and then allowed to warm up to room temperature.

The gases are nontoxic and completely harmless as long as an adequate ventilation is provided to avoid suffocation. During normal operation only 3-5 m<sup>3</sup>/day (100-180 cubic feet/day) of

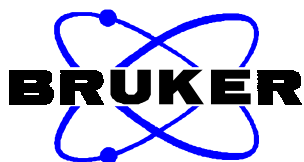

nitrogen are evaporated, but during a quench 50-100 m<sup>3</sup> (1800-3600 cubic feet) of helium are produced within a short time. Windows and doors are sufficient for ventilation even after a quench, but the NMR magnet system should never be in an airtight room.

The magnet location should be selected such that the door and the ventilation can be easily reached from all places in the room.

Room layout, ceiling clearance and magnet height should be such that an easy transfer of liquid nitrogen and helium is possible. This will considerably reduce the risk of accidents.

## 1.5 Table of Properties of Cryogenic Substances

Properties	Nitrogen	Helium
Molecular weight	28	4
Normal boiling point	-196 77	-269 4.2
Approximate expansion ration (volume of gas at 15°C and atmospheric pressure produced by unit volume of liquid at normal boiling point).	680	740
Density of liquid at normal boiling point	[kg m <sup>-3</sup> ] 810	125
Color (liquid)	none	none
Color (gas)	none	none
Odour (gas)	none	none
Toxicity	very low	very low
Explosion hazard with combustible material	no	no
Pressure rupture if liquid or cold gas is trapped	yes	yes
Fire hazard: combustible	no	no
Fire hazard: promotes ignition directly	no	no
Fire hazard: liquefies oxygen and promotes ignition	yes	yes

---

## 2 Important Notes

---

### 2.1 Important Notes

---

**Read this first!**

Please read the following pages carefully before installation or operation of your NMR magnet system:

- Hazards associated with UltraShield™ superconducting NMR magnet systems
- Cryostat installation
- Magnet charging procedure
- NMR experiments at extreme temperatures

### 2.2 Hazards

---

**Hazards associated**

The high stray field in the close vicinity of an UltraShield™ superconducting NMR magnet system is potentially dangerous. This tends to be overlooked as it is belied by a relatively harmless appearance.

**Shielding**

The fact that the UltraShield™ superconducting NMR magnet system has a minimized stray field leads to another danger: Directly above and directly below the magnet, the stray field is very strongly increasing with decreasing distance and thus the attractive forces on magnetic items are very strong!

**Attractive forces**

The stray field will exert an enormous attractive force on any iron or magnetic object in the immediate vicinity of the NMR magnet system, transforming such objects into projectiles capable of causing considerable harm to persons in the way and of course, the magnet and the objects themselves. Special care is essential in the vicinity of high field or large bore magnets because their attractive forces are effective even at rather large distances from the cryostat.

**Electronic devices**

It must also be realised that strong magnetic fields may adversely affect a range of electronic devices including those directly controlling or assisting human vital functions, eg. cardiac pacemakers. Great attention must be paid to this possible hazard as even comparatively low magnetic fields may prove dangerous in this respect. In conclusion, for the reasons outlined above, it is essential to declare the area around the NMR magnet system a hazardous zone and to limit the access. Detailed recommendations for this particular NMR magnet system are given in chapter 3 of this manual.

## 2.3 Cryostat Installation

**Cryostat installation** Cryostat installation must be done by experienced cryogenic engineers only.

The vacuum chamber of the cryostat was closed under nitrogen atmosphere in order to avoid penetration of moisture and impurities. Please do not open the vacuum valve unless necessary.



**Specified loss rates**

This is an ultra low loss cryostat. Because of its excellent thermal insulation it normally takes a very long time (often several weeks), before the internal radiation shields have cooled down to their operation temperatures. During this cooling down period the helium losses can be considerably higher than specified.

In order to accelerate this cooling down process we recommend transferring liquid helium in stages at intervals of 3 to 4 days into the helium can. Each transfer will overcool the neck tubes and in this way help to remove the heat from the radiation shields.

The helium vessel of the cryostat must always be closed with a one way valve when cold.



**Important**

Cryostat warm up must be done exactly according to the procedures outlined in chapter 3 of this manual. Fast warm up by breaking the vacuum should be done by **experienced cryogenic engineers only**.

**Helium recovery systems**

If a helium recovery system is used, this system must be connected only with a special assembly available as an accessory from Bruker. Failure to do so or modifications of the assembly will terminate the magnet system warranty, due to high quench risks.

## 2.4 Handling of UltraShield™ superconducting NMR Magnet Systems

**Magnet charging procedure**

This magnet is operating at a very high field. It is possible that during the charging procedure a few training quenches may occur to accommodate the stress changes in the magnet. These quenches are usually harmless, however they must be considered as a temporarily high thermal and mechanical strain to the magnet and should be avoided as far as possible.

Therefore we recommend that the NMR magnet system is kept on field permanently, even during longer periods where no measurements are performed, such as vacation times.



**Z and Z<sup>2</sup> Shims**

Normally, the magnet is equipped with a superconducting Z shim and Z<sup>2</sup> shim. **The Z and Z<sup>2</sup> shim heaters must be permanently "ON" during the charging and discharging of the magnet to avoid quenching the magnet.**

<b>Z<sup>2</sup> Shift</b>	The magnet should be charged above or below the nominal field to compensate the Z <sup>2</sup> shift (some kHz) generated by the Z <sup>2</sup> shim.
<b>Persistent mode</b>	The use of the shorting plugs for permanent magnet protection in the persistent mode is described in chapters 3 and 5 of this manual.
<b>Magnet shimming</b>	Before starting the shimming procedure itself, set the shim currents as stated in the characteristic data table. Due to the high efficiency of the cryo shims, they are influencing strongly the magnetic field of the magnet.

**Important****Change shim currents slowly.****Cycling of shims**

If setting of cryo shims causes irreversible frequency shifts, cycling of shims helps to get stable conditions within the magnet system. Cycling of shims is essential for 600 MHz NMR magnet systems and UltraShield™ 500 MHz NMR magnet systems!

## 2.5 Special NMR Experiments

**NMR Experiments at extreme temperatures**

This spectrometer is designed to make longtime experiments at the specified lowest and highest probe temperatures. However, when preparing and running such experiments, some care must be taken to avoid excessive temperatures on the magnet flanges and O rings.

For high temperature experiments, adequate cooling has to be provided to the cooling lines of the probehead.

For epoxy shim systems, adequate air cooling between the shims and the magnet bore tube has to be permitted. For low temperature experiments, cooling losses to the magnet bottom flange have to be avoided.

A good indicator of cooling losses during low temperature experiments is the formation of ice at the lower part of the probehead and its connection to the cold gas supply. A small cover of ice is normal, however this cover should not exceed 1 cm in thickness, and not reach the magnet bottom flange. The following parts have to be checked if excessive ice formation is observed.

1. Nitrogen transfer tube (N<sub>2</sub> supply to the probehead): Evacuate (stainless steel version) or replace if necessary (glass version).
2. Vertical transfer dewar within probehead: Replace if necessary.
3. Probehead dewar (around probe and receiver coil): Replace if necessary.
4. Dewar seal on probehead dewar: Seal with teflon tape if leaky.

In extreme cases, excessive cooling losses may lead to a cool down

of the magnet bottom flange. In this case the cryostat vacuum seal may get leaky and the magnet will quench due to helium loss. To prevent this, the low temperature experiment must be interrupted before the cryostat bottom flange reaches the freezing point. The bottom flange must be allowed to warm up. The reason for the cooling losses has to be eliminated before the experiment can be continued.

## 2.6 Discharging and Warming Up of the UltraShield™ NMR Magnet System

### Magnet discharging procedure

Bruker NMR magnet systems are equipped with an internal diode for switch protection and discharging. Before starting the discharging of a NMR magnet system, be sure to have enough helium in the helium vessel. Prepare the cryo power supply and all cabling before extracting the shorting connector from its place. Discharge the magnet according to the discharging rates in chapter 3 of this manual. **The Z and Z<sup>2</sup> shim heaters must be permanently "ON" during discharging of the magnet.**

### Magnet system warming up procedure

After having discharged the magnet coil, blow out the remaining cryogenic liquids from the helium vessel and the nitrogen vessel before breaking the vacuum in the vacuum chamber!



### Important

Cryostat warm up must be done exactly according to the procedures outlined in chapter 4 and 5 of this manual. Fast warm up by breaking the vacuum should be done by **experienced cryogenic engineers only.**



### Breaking the vacuum

The use of nitrogen gas to break the vacuum is **essential**. Never use helium gas to flood the vacuum chamber - the super insulation would be irreversibly contaminated with helium gas!

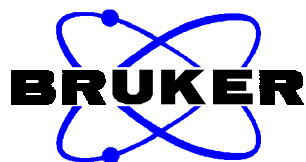

### 3 Superconducting UltraShield™ NMR Magnet

#### 3.1 Characteristic Data

Proton Frequency	MHz
Central Field	Tesla
Coil Inductance	Henry
Magnetic Energy	M Joule
Magnetic center from top flange *)	mm
Main Coil Heater Current	mA
Shim Coil Heater Current	mA

		Magnet-Test	System-Test	Customer Site
Magnet Current	A			
X-Shim Current	A			
Y-Shim Current	A			
Z-Shim Current	A			
XZ-Shim Current	A			
YZ-Shim Current	A			
XY-Shim Current	A			
X <sup>2</sup> -Y <sup>2</sup> -Shim Current	A			
Z <sup>2</sup> -Shim Current	A			
Z <sup>3</sup> -Shim Current	A			
Frequency change due to Z <sup>2</sup> -Shim and Cycling of Shims	kHz			
Magnetic center from top flange	mm			
RT Shim System Angle **)	Deg			
Visa				
<b>Important: During charging Z and Z<sup>2</sup> shim heaters must be permanently ON</b>				
<b>Remarks:</b>				

\*) Approximate values (mechanical drawings) after cool down.

\*\*) Measured from the righthand He stack to the cable input of the RT shim system.

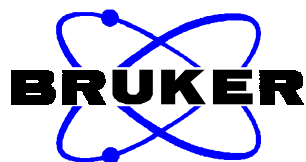

### 3.2 Resistance Measurements

<b>Measurements at room temperature with the current lead mounted in the cryostat:</b>					
from	A	Connector A		OHM	Main Heater
to	L	Connector B			
from	C	Connector A		OHM	Z Heater
to	L	Connector B			
from	E	Connector A		OHM	X Heater
to	L	Connector B			
from	F	Connector A		OHM	Y Heater
to	L	Connector B			
from	H	Connector A		OHM	XZ Heater
to	L	Connector B			
from	J	Connector A		OHM	YZ Heater
to	L	Connector B			
from	K	Connector A		OHM	XY Heater
to	L	Connector B			
from	L	Connector A		OHM	X <sup>2</sup> -Y <sup>2</sup> Heater
to	L	Connector B			
from	D	Connector A		OHM	Z <sup>2</sup> Heater
to	L	Connector B			
from	K	Connector B		OHM	Z <sup>3</sup> Heater
to	L	Connector B			
from	A,B	Connector B		OHM	Shim Coils +/-
to	D,E	Connector B			
from	+	High Curr. Conn.		OHM	High Current to
to	H	Connector B			Sense +
from	+	High Curr. Conn.		OHM	Main Coil
to	-	High Curr. Conn.			
from	-	High Curr. Conn.		OHM	High Current to
to	J	Connector B			Sense -
from	H	Connector B		OHM	Sense +
to	J	Connector B			Sense -
from	A,B	Connector B		OHM	Shim Coil to
to	L	Connector B			Heater common
from	D,E	Connector B		OHM	Shim Coil to
to	H	Connector B			Maincoil
from	H	Connector B		OHM	Sense to
to	L	Connector B			Heater common
from		the Connectors		OHM	Insulation
to		the Ground			Magnet to Dewar
<b>At room temperature with connection lead for the ACD* mounted in the cryostat:</b>					
from	K	Connector ACD*		OHM	Upper Temperature
to	J	Connector ACD*			Sensor PT100
from	A	Connector ACD*		OHM	Lower Temperature
to	B	Connector ACD*			Sensor PT100



### 3.3 Cool down Data

#### Reasons for precooling

Superconducting magnets are operated at the temperature of liquid helium, at 4,2°K.

To cool down the magnet, one uses liquid nitrogen and liquid helium. Precooling with liquid nitrogen saves a lot of liquid helium.

Since liquid nitrogen has a rather high specific heat, it is possible to generate high temperature gradients within the coil during the cool down procedure. These temperature gradients cause large mechanical stress that may result in quenches during charging!

Large coils and high field magnets must be cooled down very slowly. Coils made of aluminium are less sensitive than coils made of stainless steel, because of the very high thermal conductivity of aluminium.



#### Important Note:

**Magnets containing stainless steel coils and/or NbSn<sub>3</sub> coils manufactured by Bruker AG must not be cooled down without an Automatic Cooling Device (ACD\*).**

To prevent damage to the sensitive coils during cool down, Bruker AG has developed the Automatic Cooling Device and equipped all coils with two PT100 temperature sensors. The ACD\* limits the maximum temperature difference between the top and the bottom of the coil to 25°K.

#### Time between cool down and charging

Due to the large mass of the coil, some time is needed after the initial cool down procedure for the inner parts of the magnet coil to stabilize at the temperature of liquid helium.



#### Important Note:

With this magnet type, the time between cool down and charging must be **at least 12 hours!**

#### Cool down with liquid helium

The ACD\* may be used to control the temperature of the coil also during the cool down with liquid helium. Due to the characteristics of the PT100 sensors, the linearisation of the PT100 below 50°K is very difficult. Below 50°K the display shows no more values in °K! As the temperature reaches 4.2°K of liquid helium, the display will show approximately "30".



#### Connection lead for the ACD\*

The 32 pin shim current rod fits in the left helium turret and makes the connection between the PT100 sensors on the magnet coil and the ACD\*.

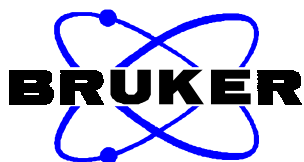

<b>Cooling down WITH Automatic Cooling Device ESSENTIAL</b>				
Magnet system	with ACD* cooling	without ACD* cooling	Time A	Time B
300/174A	yes	prohibited	x	-
400/107C	yes	prohibited	x	-
600/70A	yes	prohibited	x	-
600/70B	yes	prohibited	x	-
700/70A	yes	prohibited	x	-

<b>Cooling down WITH Automatic Cooling Device RECOMMENDED</b>				
Magnet system	with ACD*	cooling without ACD*	cooling Time A	cooling Time B
300/107B	yes	yes	x	-
300/174B	yes	not recommended	x	-
400/67C	yes	yes	x	-
400/70E & F	yes	yes	x	-
400/107E	yes	not recommended	x	-
500/67E	yes	not recommended	x	-
500/67H	yes	not recommended	x	-
500/70A & B	yes	not recommended	x	-

<b>Cooling down WITHOUT Automatic Cooling Device POSSIBLE</b>				
Magnet system	with ACD* cooling	without ACD* cooling	Time A	Time B
all other magnet types	yes	yes	x	-

\* ACD = Automatic Cooling Device

### 3.4 Charging Rates

**Charging record** To prevent quenching the magnet strictly follow the charging table. Keep a charging record with time table, magnet current and helium level. These informations are very helpful in case of problems.



**Shim heaters** To prevent inducing currents in the shim coils during the charging procedure, all shim heaters must be periodically heated.  
**Always put Heater Automatic to the ON position!**  
 Due to the strong action of the Z and Z<sup>2</sup> shims, these two shim heaters should be quenched permanently.  
**Always put Z and Z<sup>2</sup> shim heaters to the ON position!**

MAGNET CURRENT				SENSE VOLTAGE
0	to	70	Ampere	4000 mV
70	to	100	Ampere	3000 mV
100	to	120	Ampere	2000 mV
120	to	140	Ampere	1000 mV
140	to	150	Ampere	500 mV
<b>Pause over nighth</b>				
150	to	155	Ampere	300 mV
155	to	160	Ampere	200 mV
160	to		Ampere	100 mV
			% Overshoot	50 mV
<b>10 Minutes Pause at Overshoot Current</b>				0 mV
Back to final field				- 50 mV

**Charging time** Calculated charging time (first day): 6 hours 2 minutes  
 Calculated charging time (second day): 5 hours 6 minutes  
 Total charging time (without pause): 11 hours 8 minutes



**Minimum helium level** **Keep the helium level above 85% while charging or shimming the magnet.**

**Persistent mode** For persistent operation the two 32 pin shorting plugs must be mounted in place of the main current lead and of the shim current lead in the rear respectively in the left helium turret. Immediately after having the magnet persistent, the 32 pin main shorting plug must be inserted into the rear helium turret.

**32 pin main shorting plug** The 32 pin main shorting plug will make a short circuit only across the main coil.  
**Leave it in its place also during the shimming procedure of the magnet.**



**After a quench** After a quench and after having refilled the helium vessel, the coil should be allowed to cool down for **12 hours** before energizing it again.

### 3.5 Cycling of Shims and Shimming

**32 pin main shorting plug** While shimming, the 32 pin main shorting plug must be mounted in the third helium neck to protect the main coil switch. This 32 pin main shorting plug will make a short circuit only across the main coil.

**Time between charging and shimming** After having charged the magnet, the coil needs some time to reach stable conditions. During the first hours in the persistent mode, rather high drift rates may be observed due to internal stabilisation of the current densities in the superconducting wires.



**Important Note:** Leave the **Shim Heater Automatic ON** during the first night after charging the magnet.

During the first hours after having the magnet persistent, it is not recommended to change any shim currents.



**Cycling of cryo shims** **With this type of magnet wait overnight before starting the cycling of the cryo shims.**

**Stable conditions**

Before shimming the magnet, the operator should charge all the shims at least two times with the shim currents given below and allow the shims some minutes to hold these currents.

**Change these currents slowly!**

X-Shim Current		A
Y-Shim Current		A
Z-Shim Current		A
Z <sup>2</sup> -Shim Current		A
Z <sup>3</sup> -Shim Current		A
XZ-Shim Current		A
YZ-Shim Current		A
XY-Shim Current		A
X <sup>2</sup> -Y <sup>2</sup> -Shim Current		A
Approximate frequency shift during cycling of shims		kHz



**Shimming of cryo shims**

**With this type of magnet wait overnight before starting the shimming procedure!**

The shim currents for optimum homogeneity, found during magnet and system test, are stated in chapter 3.1. These shim currents have to be optimized during the installation.

**Please note the actual currents under "customer site"!**



**Important Note:**

**After having finished the shimming procedure, replace the shim current lead with the 32 pin shim shorting plug with the correct procedure!**



**Bursting disk**

After having energized and shimmed the magnet, replace the sealing plug on the rear helium turret with the bursting disk and the second radiation baffle.

### 3.6 Replacing the main current lead with the 32 pin main shorting plug

**Internal diode** This magnet is equipped with an internal diode for switch protection and discharging. The diode protects the main switch at all times, as long as the current polarity is not reversed. If the magnet's main switch should open accidentally, this diode limits the discharging voltage to ~ 1.2 volts.

1. Before extracting the 32 pin main current lead from its place, the 32 pin shim shorting plug must be inserted into the left helium neck. Be sure, the 32 pin shim shorting plug is inserted completely into the left connector.
2. Remove the main current lead.
3. Immediately close the helium neck by inserting the dry and warm 32 pin main shorting plug into the rear helium turret using the shorting plug insertion rod.
4. Remove the shorting plug insertion rod and close the rear helium neck with the sealing plug immediately before proceeding.



**Baffles** **Do not forget to insert the two radiation baffles into the left and the rear helium necks!**

**Bursting disk** 5. The rear helium turret is closed with the bursting disk. Check the O-ring on the sealing surface before fixing the bursting disk with the second radiation baffle on the rear helium neck.

### 3.7 Replacing the shim current lead with the 32 pin shim shorting plug

**Internal diode** This magnet is equipped with an internal diode for switch protection and discharging. The diode protects the main switch at all times, as long as the current polarity is not reversed. If the magnet's main switch should open accidentally, this diode limits the discharging voltage to ~ 1.2 volts.

1. Before extracting the shim current lead from its place, the 32 pin shorting plug must be inserted into the rear helium neck. Be sure, the 32 pin main shorting plug is inserted completely into the rear connector.
2. Remove the shim current lead.
3. Immediately close the helium neck by inserting the dry and warm 32 pin shim shorting plug using the shorting plug insertion rod.
4. Remove the shorting plug insertion rod and close the left helium neck with the helium oscillation damper, baffle, O ring and screw cap.



**Baffles** Do not forget to insert the two radiation baffles into the left and the rear helium necks!

### 3.8 Standard operation

**Standard operation** Please refer to chapters 3 to 4 for standard operation specifications.

**Shorting plug** During standard operation of the NMR magnet system the two 32 pin shorting plugs are always inserted in the left and the rear helium turret.

**Radiation baffles** Always leave the two radiation baffles in the left and in the rear helium neck tube.

**Bursting disk** Always leave the bursting disk on the rear helium turret when the magnet is energized.

**Oscillation damper** Always leave the oscillation damper mounted on the left helium neck. Otherwise thermoacoustic oscillations could lead to high boil off and thus reduce the helium hold time!

**One way valve** Always leave the one way valve mounted on the helium manifold. This one way valve may stay on the helium manifold even when refilling helium!

**Nitrogen security flow system** Always leave the nitrogen security flow system mounted on the nitrogen necks, especially during refill of helium, to prevent moisture and air entering the nitrogen vessel. Do not remove the heat exchanger with the red nitrogen security one way valve - leave it always at its place also during the refill of nitrogen!

**Trouble shooting** Please refer to chapter 6 for trouble shooting procedures.



**Important** Before shimming, charging or discharging the magnet, replace the two shorting plugs with the main current lead and the shim current lead with the correct procedures.

### 3.9 Replacing the 32 pin main shorting plug with the main current lead



**Important** Prepare the cryo power supply and all cabling before extracting the main shorting plug from its place in the rear helium turret! This operation is needed before changing the current in the main coil only.

1. Before extracting the 32 pin main shorting plug from its place, be sure, the 32 pin shim shorting plug is inserted completely into the left connector.

2. Remove the 32 pin main shorting plug with the shorting plug insertion rod.
3. Immediately close the helium neck by inserting the dry and warm current lead with mounted O ring and screw cap. Close the helium neck with O ring and screw cap.
4. **Immediately connect the main current cable to the current lead. Put a short circuit connector to the main current cable until charging or discharging**
5. Remove the 32 pin shim shorting plug and insert the shim current lead according to chapter 3.11 .

### 3.10 Replacing the 32 pin shim shorting plug with the shim current lead



#### Important

**Prepare the cryo power supply and all cabling before extracting the shim shorting plug from its place in the left helium turret! This operation is needed before shimming the cryo shims or before changing the current in the main coil after having inserted the main current lead !**

1. **Before extracting the shorting plug from its place make sure either the 32 pin main shorting plug is inserted completely into the rear connector or the main current cable is connected correctly to the inserted main current rod..**
2. Remove the 32 pin shim shorting plug with the shorting plug insertion rod.
3. Immediately close the helium neck by inserting the dry and warm shim current lead with mounted O ring and screw cap. Close the helium neck with O ring and screw cap.
4. **Immediately connect the control cable to the shim current lead. Make sure the two cable connectors A and B are connected correctly to the two connectors A and B on the shim current lead!**



### 3.11 Discharging Rates

**Discharging record** To prevent quenching the magnet strictly follow the discharging table. Keep a discharging record with time table, magnet current and helium level. This information is very helpful in case of problems.



**Shim heaters** To prevent inducing currents in the shim coils during the discharging procedure, all shim heaters must be periodically heated.  
**Always put Heater Automatic to the ON position!**  
 Due to the strong action of the Z and Z<sup>2</sup> shims these two shim heaters should be quenched permanently.  
**Always put Z and Z<sup>2</sup> shim heaters to the ON position!**

**Internal diode** This magnet is equipped with an internal diode for switch protection and discharging. The diode protects the main switch at all times, as long as the current polarity is not reversed.

MAGNET CURRENT				SENSE VOLTAGE
	to	160	Ampere	150 mV
160	to	155	Ampere	300 mV
155	to	150	Ampere	500 mV
150	to	140	Ampere	800 mV
140	to	120	Ampere	1400 mV
120	to	100	Ampere	2000 mV
100	to	0	Ampere	through external diodes

**Discharging time** Calculated discharging time (without pause): 8 hour 57 minutes

## 4 Long Hold Cryostat

### 4.1 Cryostat Installation

Dewar xxx/dd

**Unpacking**                      Unpack the cryostat carefully. Inspect the shock watches and the tilt indicators.



**Important:**                      **Any indication of transportation damages must be reported immediately to the transport company and to Bruker Magnetics! The transportation insurance will be void if the damages are not reported in detail.**

**Lifting by crane**                      To lift the NMR magnet system always use the special hoist or four (4) slings and all four (4) hooks at the cryostat! The minimum lifting capacity must be 3000 kg!

**Assembling feet**                      Immediately mount the three assembling feet to the bottom of the cryostat.



**Important:**                      **Make sure that the cryostat is always carefully levelled also when the cryostat is hanging on the crane!**

**Room height**                      The entire assembly of the cryostat may be done on the long (850 mm) assembling feet and on the Anti Vibration Stand if there is 3.6 meters (12 ft) or more of ceiling height.



**Level Sensor**                      **Insert the helium level sensor into the right helium neck before lifting the cryostat up on the Anti Vibration Stand.**

With 3.3 meters to 3.6 meters (11 - 12 ft) of ceiling height the assembly has to be done on the short and on the long assembling feet alternately. The cryostat is mounted on the Anti Vibration Stand after the assembly is finished .

**Levelling**                      Due to the large mass of the magnet coil in the helium vessel the entire assembly and aligning procedure must be done with a perfectly levelled system!

**Moving after assembly**                      **The NMR magnet system must not be moved after assembly at all!**



**Important:**                      **Do not transport the NMR magnet system without inserted transport fixture! The magnet stand and the cryostat must be assembled directly at the final place of operation.**

---

## 4.2 Preparation of Disassembly of the Transport Fixture

---

1. Lift the magnet system with the special hoist to the maximum height of the special mounting crane or with any crane that allows a minimum load of 3000 kg at least 850 mm above the floor.
2. Mount the 850 mm long mounting feet to the bottom plate and put the magnet system on these mounting feet.
3. Secure the magnet system with lifting belts to the mounting crane.
4. Remove the special hoist to get free access to the upper end of the room temperature bore.

---

## 4.3 Disassembly of the Transport Fixture

---



**Caution:** The different parts of the transport fixture are heavy - be careful during disassembly!

---

1. Loosen the central steel rod. Remove the two nuts (30 mm) and the upper steel rod.
2. Loosen the six outer screws and remove the two top fixture plates. Do not loosen the six inner screws!  
It is not necessary to take the two pieces apart.
3. Extract the long top fixture flange.
4. Extract the two parts of short top fixture flanges. Do not loosen the six screws! It is not necessary to take the two pieces apart.



**Caution:** The metallic parts of the transport fixture are heavy and could cause injury when disassembly is not done carefully. Two people are needed to carry out the following steps!

---

5. Loosen the six outer screws in the bottom fixture plates.
6. Carefully remove the entire bottom fixture (2 parts) and the threaded, central rod. Do not loosen the six inner screws!  
It is not necessary to take the two pieces apart.

---

## 4.4 Preparation of Disassembly of the Transport Fixture at Low Ceiling Heights

---

1. Lift the magnet system with the special hoist to the maximum height of the special mounting crane or with any crane that allows a minimum load of 3000 kg.
2. Mount the short mounting feet to the bottom plate and put the magnet system on these mounting feet.
3. Remove the special hoist to get free access to the upper end of the room temperature bore.

#### 4.5 Disassembly of the Transport Fixture at Low Ceiling Heights



**Caution:**

**The different parts of the transport fixture are heavy - be careful during disassembly!**

1. Loosen the central steel rod. Remove the two nuts (30 mm) and the upper steel rod.
2. Loosen the six outer screws and remove the two top fixture plates. Do not loosen the six inner screws!  
It is not necessary to take the two pieces apart.
3. Extract the long top fixture flange.
4. Extract the two short top fixture flanges. Do not loosen the six screws! It is not necessary to take the two pieces apart.
5. Lift the magnet system with the special hoist to the maximum height of the special mounting crane or with any crane that allows a minimum load of 3000 kg at least 850 mm above the ground.
6. Mount the 850 mm long mounting feet to the bottom plate and put the magnet system on these mounting feet.
7. Secure the magnet system with lifting belts to the mounting crane.



**Caution:**

**The metallic parts of the transport fixture are heavy and could cause injury when disassembly is not done carefully. Two people are needed to carry out the following steps!**

8. Loosen the six outer screws in the bottom fixture plate.
9. Carefully remove the entire bottom fixture (2 parts) and the threaded, central rod. Do not loosen the six inner screws!  
It is not necessary to take the two pieces apart.

#### 4.6 Disassembly of the Transport Fixture of the Nitrogen Vessel

1. Loosen the nuts on the rods of the transport fixtures of the nitrogen vessel.
2. Remove the rods of the transport fixtures of the nitrogen vessel.

#### 4.7 Assembly of the Transport Fixture



**Caution:**

**Disassembly of a cold cryostat leads to massive collection of moisture within the whole vacuum chamber. All metallic surfaces and the super insulation become wet and may be damaged or destroyed!**

2. Remove the cryostat's top and bottom closure flanges and take the RT bore tube out of the cryostat.
3. Remove the cryostat's top and bottom reduction flanges and take the N<sub>2</sub> bore tube out of the cryostat.
4. Loosen the alignment rods between the N<sub>2</sub> vessel and the outer vacuum chamber (OVC).
5. Insert the two short top fixture flanges. They may be fixed non concentrically to fit exactly into the cryostat.
6. Insert the long top fixture flange.
7. Insert the two top fixture plates and fix them with the outer six screws to the OVC.
8. Insert the bottom fixture flange, the bottom plate and the threaded, central rod. They may be fixed non concentrically to fit exactly into the cryostat.

**Important Note:**

**Push back the super insulation before inserting the fixture flanges. The super insulation must not be trapped by the fixture flanges!**

---

9. Insert the top steel rod through the top fixture flanges and screw it into the threaded nut of the bottom steel rod.
10. Tighten the steel rods. Apply some prestress with the 30 mm nut and secure the whole transport fixture with the second 30 mm counter nut.

#### **4.8 Assembly of the Transport Fixture of the Nitrogen Vessel**

---

1. Insert the rods of the transport fixtures into the nitrogen turrets.
2. Tighten the nuts on the rods of the transport fixtures of the nitrogen vessel.

#### 4.9 Alignment of the N<sub>2</sub> Vessel and the Outer Vacuum Chamber (OVC)



**Important:** Due to the large mass of the magnet coil in the helium vessel the entire assembly and aligning procedure must be done with a perfectly levelled system!

1. Fix the zeolith getter on the bottom plate of the helium vessel.
2. Fix the N<sub>2</sub> bottom flange and the bottom reduction flange with two screws each and check the alignment of the N<sub>2</sub> vessel and of the OVC.
3. Adjust the alignment if necessary.
4. Repeat 2. and 3. as long as needed.



**Important:** Do not apply prestress to all three alignment rods. Move the N<sub>2</sub> vessel in the correct position with one or two of the alignment rods and slightly tighten the others!



**Important:** 5. If the alignment is completed, tighten all the alignment screws by exactly 1 + 1/3 turn.

6. Check the final alignment of the N<sub>2</sub> vessel and the OVC.
7. Remove the bottom reduction flange.
8. Check the final alignment from the top with the bottom flange inserted between the N<sub>2</sub> vessel and the OVC. It must be exactly concentric.

#### 4.10 Alignment of the Helium Vessel and the N<sub>2</sub> Vessel

Dewar xxx/dd



**Important** The following steps have to be carried out by an experienced cryogenic engineer only!  
The alignment between the He vessel and the N<sub>2</sub> vessel has been adjusted during production and normally does not require adjustment after transportation!

9. Check the alignment between the He vessel and the N<sub>2</sub> vessel.



**Important:** Due to the large mass of the magnet coil in the helium vessel, the entire assembly and aligning procedure must be done with a perfectly levelled system!

10. Adjust the alignment if necessary.
11. Repeat 9. and 10. as long as needed.
12. Mount the N<sub>2</sub> bottom flange definitively on the N<sub>2</sub> vessel.
13. Fix the bottom reduction flange with two screws and check whether the alignment of the N<sub>2</sub> vessel and the OVC is still ok.

14. Remove the bottom reduction flange.
15. Mount the N<sub>2</sub> super insulation definitively on the N<sub>2</sub> bottom flange.



Note:

**Make sure that the superinsulation is not touching any other vessel.**

16. Mount the bottom reduction flange definitively with the cleaned and slightly greased O ring and tighten all screws.

#### 4.11 Insertion and Alignment of the N<sub>2</sub> Bore Tube and of the Room Temperature Bore Tube

17. Mount the bottom closure flange without O ring and fix it with two screws.
18. Depending on the ceiling height the cryostat must be lowered on the short mounting feet.



Note:

**The two holes for improved pumping efficiency must be at the lower end of the N<sub>2</sub> bore tube!**

19. Insert the N<sub>2</sub> bore tube from the top of the cryostat and press it firmly into the bottom N<sub>2</sub> flange. The two holes for improved pumping efficiency are located at the lower end!
20. Align the N<sub>2</sub> bore tube and the helium can at the upper end with the alignment tool (Z54368) and fix the top N<sub>2</sub> flange with the fixture ring. (see next figures)
21. Insert the top flange and fix it as marked. This flange may be non concentric - be sure to fix it with the correct orientation!
22. Check the alignment of the upper end of the N<sub>2</sub> bore tube and the OVC.
23. Insert the RT bore tube. Insert the top reduction and closure flanges with the O rings and fix them.
24. Remove the bottom closure flange, insert the bottom closure flange with the O ring and fix it again.
25. Insert the KF 40 vacuum valve and the check the two drop off plates on the top of the cryostat.
26. Pump and flush the OVC three to four times with dry nitrogen gas.
27. Start pumping the OVC.

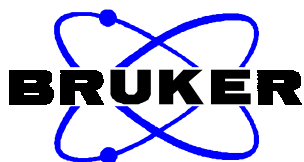
**4.12 Liquid Helium****Dewar xxx/dd**

Initial filling	ltr
Difference between maximum and minimum allowed level	ca. ltr
Boil off rate <sup>1)</sup>	ca. mltr / h
Hold time <sup>2)</sup>	> days
(Volume He vessel) x (maximum allowed pressure difference) <sup>3)</sup>	bar x ltr

**4.13 Liquid Nitrogen****Dewar xxx/dd**

Initial filling	ltr
Volume between maximum and minimum allowed level	ca. ltr
Boil off rate <sup>1)</sup>	< mltr/h
Hold time <sup>2)</sup>	> days
(Volume N <sub>2</sub> vessel) x (maximum allowed pressure difference) <sup>3)</sup>	bar x ltr

- 1) Mean value measured under stable normal conditions (@ 20°C and @ 1030 mbar)
- 2) Maximum time interval between two fillings
- 3) Maximum allowed operation pressure: 350 mbar (4.9 psi), maximum allowed pressure difference between vessels and outer vacuum chamber: 1350 mbar (19 psi)



---

## 5 Installation procedures for Bruker Cryostats

### Safe handling of Bruker NMR Magnet Systems

---

#### 5.1 Assembly of the NMR magnet system

---

##### Transport fixture

1. Disassemble the transport fixture carefully. For the details of the construction of the transport fixture see chapter 4.



##### Caution

**The transport fixtures of large NMR magnet systems contain heavy metallic parts - be careful during disassembly!**

##### Assembly

2. Check the radial fixtures of the helium and of the nitrogen can.
3. Assemble the cryostat carefully. Avoid contamination of all clean surfaces. Clean and slightly grease all O rings. For details of the assembling procedure see chapter 4.

#### 5.2 Pumping of the NMR magnet system

---

4. Pump and flush the vacuum vessel at least three to four times with dry and clean nitrogen gas to remove moisture.
5. Pump the vacuum vessel for at least 24 hours. Final pressure should be below  $5 \times 10^{-5}$  mbar, measured at the pumping unit.

#### 5.3 Preparing the NMR magnet system for the Cool Down Procedure

---

6. Mount the helium turrets carefully to avoid any leak. Clean and slightly grease all O rings. Check the proper position of the spheres and O rings in the quench valves.
7. Insert the current lead, mark the correct depth on the lead head. Check all resistances according to chapter 3.3.
8. Check the cabling of the helium level sensor.
9. Check the zero reading of the helium level sensor.

### 5.4 Cool down procedure with Automatic Cooling Device (ACD\*)

1. Remove the current lead and insert the connection lead for the ACD\*. Dry the plug with warm air before insertion.
2. Test the connection lead for the ACD\*. The Automatic Cooling Device shows approximately room temperature (~ 293°K).
3. **Test insertion of the auxiliary shorting plug.**
4. Make sure the magnet is dry before cool down. Flush and pump several times at room temperature with dry nitrogen gas.



**Minimum vacuum**

Do not start the cool down procedure before the pressure is below  $5 \times 10^{-5}$  mbar, measured at the pumping unit.

5. Insert the precooling L-tube into the helium syphon and make sure the tube is completely inserted.
6. Install the complete Automatic Cooling Device according to the manual. Mount a one way valve on the helium turret outlets.



**600 MHz Systems only**

There is a special 22 pin connection lead for the ACD\* delivered with any 600 MHz System. It will fit into the third helium neck.

7. Precool with liquid nitrogen using 200-300 mbar (3-4 psi) pressure in the liquid nitrogen storage dewar. Use a one way valve to prevent air and moisture to enter the helium vessel. For details consult the ACD\* manual.
8. Above the temperature of liquid nitrogen (77°K), the Automatic Cooling Device stops the cool down and prevents overfilling of the helium vessel. Leave the ACD\* connected to the dewar overnight. The magnet's temperature should be between 80° K and 90° K.
9. Keep the helium can closed at all times if below room temperature. Have the exhaust only open with a large gas flow to avoid intake of moisture.
10. Mount the safety valve on the rear nitrogen outlet. Mount the teflon tubes and the nitrogen one way valve of the nitrogen flow system on the other nitrogen outlets. Fill the nitrogen vessel slowly to the top.
11. Mount the complete nitrogen flow system according to the drawings in chapter 4.



**Pumping unit**

**Do not remove the pumping unit until collection of liquid helium starts within the helium vessel. Otherwise reduced helium and/or nitrogen hold time or even vacuum loss could result!**

12. Remove all nitrogen very carefully through the precooling tube by applying a pressure of 100-150 mbar (1.5-2 psi) through the helium turrets. Remove the precooling tube.

**Important**

**Check with the dipstick through the syphon to make sure that no liquid nitrogen is left.**

### 5.5 Cool down without the Automatic Cooling Device

1. Remove the current lead and insert the shorting plug in the left-hand helium neck to prevent the connectors from icing. Dry the plug with warm air before insertion.
2. **Test insertion of the auxiliary shorting plug.**
3. Make sure the magnet is dry before cool down. Flush and pump at room temperature several times with dry nitrogen gas.

**Minimum vacuum**

Do not start the cool down procedure before the pressure is below  $5 \times 10^{-5}$  mbar, measured at the pumping unit.

4. Insert the precooling tube into the helium syphon, make sure the tube is completely inserted.
5. Supervise precooling in short intervals. Use either two nitrogen supply vessels, or cool the cryostat helium vessel first and the nitrogen vessel afterwards. Use a very low transfer pressure of 50 - 100 mbar. Often even the pressure built up in the transport dewar may be too high. Collection of liquid nitrogen should start after 4 hours or later.
6. Do not fill the helium can with more than 10 cm of liquid nitrogen. Mount the teflon tubes and the one way valve and close the precooling tube with a rubber plug. Wait overnight.
7. Keep the helium can closed at all times if below room temperature. Have the exhaust only open with a large gas flow to avoid intake of moisture.
8. Fill the nitrogen vessel slowly to the top. Mount the complete nitrogen flow system according to the drawings in chapter 3.

**Pumping unit**

**Do not remove the pumping unit until collection of liquid helium starts within the helium vessel. Otherwise reduced helium and/or nitrogen hold time or even vacuum loss could result!**

9. Remove all nitrogen very carefully through the precooling tube by applying a pressure of 100-150 mbar through the helium turrets. Remove the precooling tube.

**Important**

**Check with the dipstick through the syphon to make sure that no liquid nitrogen is left.**

## 5.6 Cool down with liquid helium

1. Pump and flush the helium vessel with helium gas 6-8 times to progressively lower pressures, starting with 900 mbar and ending below 50 mbar.

**Freezing nitrogen**

**Remember that liquid nitrogen becomes solid very quickly if pumped.  
Use short pumping times!**

2. Mount a KF25 nozzle or a helium recovery system on the helium turrets. Leave the complete nitrogen flow system mounted on the nitrogen outlets. Completely insert the helium transfer line with the extension piece into the syphon.
3. Cool down with liquid helium very slowly. Use 4-8 hours for cool down, depending on the magnet size. Apply a very low transfer pressure at the beginning and increase later.
4. Check the zero reading of the helium level sensor.

**Pumping unit**

**Do not remove the pumping unit until collection of liquid helium starts within the helium vessel. Otherwise reduced helium and/or nitrogen hold time or even vacuum loss could result!**

5. Use a transfer pressure of 10-20 mbar (max. 30 mbar). Often even the pressure built up in the transport dewar may be too high. Increase to 50 mbar at 4.2 K only.
6. Fill the helium can completely. Mount the teflon tubes and the one way valve to the helium turrets.
7. Do not open the helium can more than 5 seconds while at helium temperature and never open both turrets simultaneously. Do not leave the turrets open or directly connected to a recovery system unless a large gas flow is present.



One way valve

Always use the teflon tubes and the one way valve.

### 5.7 Charging and Shimming

1. **Wait at least one night before charging after cool down** according to chapter 3. However, do not leave the NMR magnet system at helium temperature for more than a few days without charging.
2. Refill the helium can if needed. Keep the helium level above the minimum limit given for charging.
3. Remove the shorting plug and insert the current lead. Dry the leads and plugs with warm air before insertion.
4. **Test insertion of the auxiliary shorting plug.**



600 MHz system only

**Test insertion of the 22 pin shorting plug in the third helium neck.**

5. Mount a KF25 nozzle or a helium recovery system on the helium turrets. If a recovery system is used, check the counter pressure to be below 50 mbar. Make sure there is an adequate relief valve which opens at that pressure. Do not use our special recovery line assembly during charging, as the flow is too large. Leave the complete nitrogen flow system mounted on the nitrogen outlets.
6. **Charge the magnet according to the charging table in this manual. Never leave the magnet unattended during charging. Keep a charging record.**

Overshoot

6. The stability of the magnet field after the charging procedure is strongly dependent on the process of reaching the final current. It is essential to reach a slightly higher current first (see chapter 3).



Important

**Leave the magnet with open main coil switch for 10 minutes at this overshoot current.**

7. Reduce the main coil current slowly to its final value. At the final current wait a few moments until the magnet and the cryo power supply are in a stable state with minimum sense voltage. Note the final current under "customer site" in chapter 3.1!
8. Put the main coil heater to the OFF position and supervise main coil current stability and sense voltage stability.
9. Having the magnet persistent, wait several minutes before removing the current continuously. With the B-CN100 or B-CN120 switch I-SUPPLY to the OFF position.



**600 MHz system only**

**With the 600 MHz systems insert the 22 pin shorting plug into the third helium neck to protect the main coil switch. This 22 pin shorting connector will make a short circuit only across the main coil. Leave it in its place also during the shimming procedure of the magnet!**

10. Mount a shorting connector on the main current cable. **Do not disconnect the charging cables from the NMR magnet system.**
11. Mount the teflon tubes and the one way valve on the helium turrets.
12. **Wait at least 1 hour before cryoshimming; with large magnets overnight according to chapter 3. Connect only the control cable to the power supply.**



**Large coils**

Large coils with high magnetic energy must not be shimmed immediately after charging. This concerns 600 MHz and 500 MHz Standard Bore, 400 MHz and 300 MHz Wide Bore and 300 MHz and 200 MHz Superwide Bore NMR magnet systems. **Always wait overnight before cryo shimming. Leave the control cable connected and run the shim Heater Automatic until cryo-shimming. Make sure there is always enough liquid helium in the vessel. Helium boil off will be rather high during operating the Shim Heater Automatic.**

**Cryo shimming**

13. For cryo shimming always leave the main current cable connected to the magnet current lead and mount a shorting connector on the main current cable. Leave the one way valve on the helium turrets mounted. **Change cryo shim currents slowly, especially the Z<sup>2</sup> shim current. Connect only the control cable to the cryo power supply!**



**Time Constants**

**Shims that have large time constants have to be changed very carefully. Leave the shim heater open for at least 1 minute with the needed shim current flowing through the shim before closing it.**

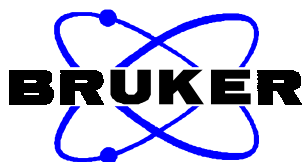

- Shorting plug**
14. After shimming, replace the current lead by the magnet shorting plug with the correct procedure according to chapter 3.
  15. The helium vessel must always be closed with a one way valve when cold. If a helium recovery system is used, this system only has to be connected with a special assembly available as an accessory from Bruker. Failure to do so or modifications of the assembly will terminate the magnet systems warranty due to high quench risks.
  16. After a quench, check the spheres and the O rings in the quench valves as soon as possible. Recool the magnet within an hour after a quench with liquid helium and wait at least the indicated time before charging it again according to chapter 3.
  17. If the magnet can not be re-cooled immediately, make sure the helium vessel is closed airtight with a one way valve.

## 5.8 Discharging Procedure

---

1. Refill the helium can up to the minimum level given for charging.
2. Prepare the cryo power supply and all cabling before extracting the shorting plug from its place.
3. Remove the shorting plug with the correct procedure according to chapter 3.
4. Connect the main current cable and the control cable to the magnet and then to the cryo power supply.
5. Discharge all shims one by one with the following procedure:
  - Set the final shim current as noted in chapter 3.1.
  - Open the shim heater, then reduce the shim current slowly to zero.
  - Close the shim heater.
6. Discharge the magnet following the discharging table in chapter 3.

### 5.9 Warm up procedure for Cryostats

Having discharged the magnet, the system can simply be allowed to run out of liquid helium and nitrogen, and left to warm up, which will take about a month.



#### Rapid warm up procedure

Discharge the magnet. Remove the current lead and mount the turret plug **without** baffle. **The fast warm up procedure should be carried out by experienced cryogenic engineers only.**

1. Remove all liquid nitrogen by passing the special N<sub>2</sub> blow out tube through one of the filler ports and by applying pressurized **dry nitrogen gas** to the other ports.  
**Never apply a pressure of more than 350 mbar (5 psi) to the nitrogen vessel**
2. Check with a dipstick if the nitrogen can is completely empty. Verify that all open nitrogen ports are free of ice. Mount the security valve to one of the ports.
3. Remove the liquid helium by removing the one way valve, inserting the precooling tube into the syphon and passing gently **dry helium gas** through it. **This will boil off the remaining liquid.**



#### Maximum pressure

**Never apply a pressure of more than 350 mbar (5 psi) to the helium vessel.**



#### Warning:

**Never use nitrogen gas or pressurized air in the helium can. Use dry helium gas only.**

4. Check with a dipstick through the syphon if the helium can is completely empty. Immediately replace the one way valve and close the syphon entry.
5. Break the vacuum very slowly with dry nitrogen gas flowing through a needle valve connected to the vacuum valve by an O ring flange **without clamps**. The gas line is then held in position by the vacuum only. It will drop off automatically once the pressure in the vacuum chamber has reached atmospheric pressure.
6. During the first three hours after breaking the vacuum the operator should be present and check repeatedly both the helium boil off as well as the nitrogen boil off: **It may be small, but if no boil off is observed, the corresponding outlets must be checked for icing.**



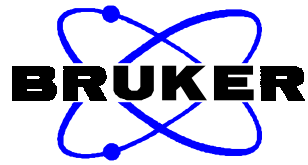

**Warning:**

**Once the vacuum is broken, never reclose the vacuum valve!**

---

7. The cryostat takes approximately four to seven days to warm up. When the room temperature bore is no longer wet and cold, the warm up procedure can be considered completed.



**Important:**

**Never disassemble a dewar before the warm up procedure is completely finished. Condensing moisture will damage the dewar and the super insulation!**

---

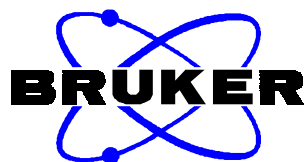

### 5.10 Temperature Sensor PT100

This magnet is equipped with two platinum resistors as temperature sensors.

**Note:** Measure the resistance with a maximum current of 1 mA.

Calibration data	Temperature	Resistance
Room temperature	293 K	107,8 Ohm
	273 K	100,0 Ohm
	250 K	91,0 Ohm
	200 K	71,1 Ohm
	150 K	50,9 Ohm
	100 K	30,0 Ohm
Liquid nitrogen	77 K	20,1 Ohm

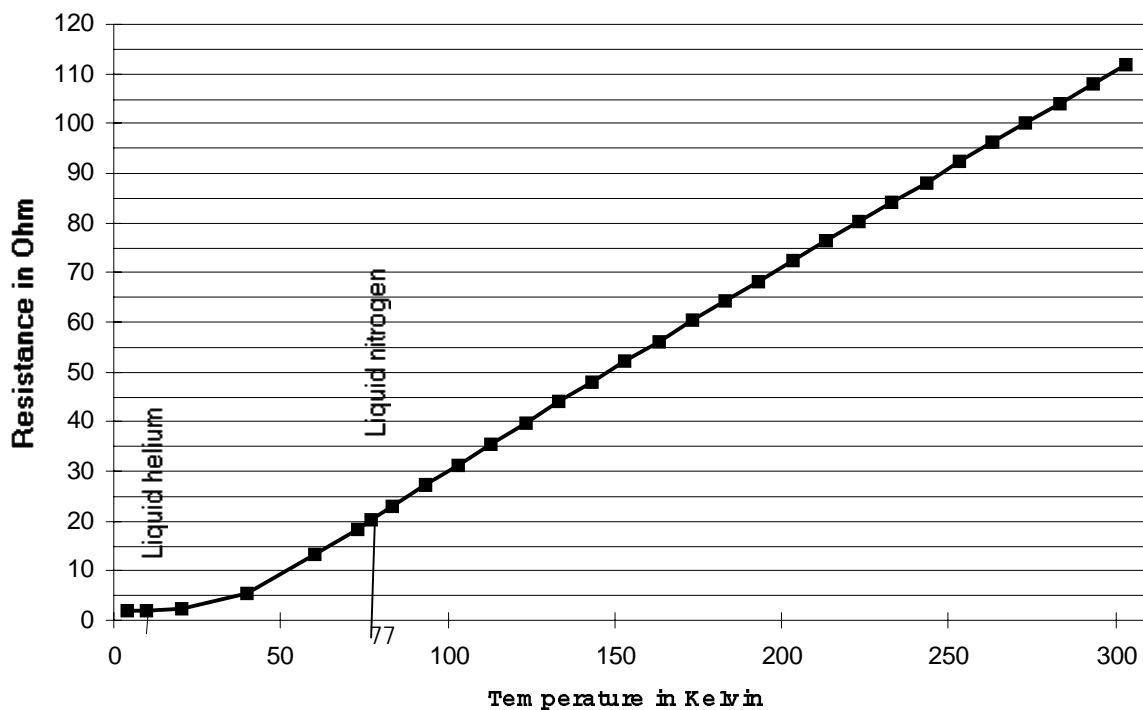

---

## 5.11 Safety Recommendations in the High Field NMR Laboratory

---



**Safety considerations** Superconducting NMR magnet systems cause potential safety hazards due to their extended magnetic stray field, their large attractive forces on ferromagnetic objects and their large content of cryogenic liquids. It is the sole responsibility of our customers to ensure safety in their NMR laboratories and to comply with local safety regulations. Bruker is not responsible for any injuries or damages due to an improper room layout or due to improper operation routines.

**Magnetic stray field** It is generally accepted that stray fields are harmless below 5 Gauss (ten times the earth magnetic field). Stronger stray fields closer to the NMR magnet system may disturb heart pace makers, erase magnetic cards and storage devices and adversely affect watches and micro mechanical devices.



**Limited access** It is therefore recommended to mark the 5 Gauss line with warning signs and to limit access to areas with more than 10 - 20 Gauss field to the NMR staff only. Be aware that a magnetic stray field extends in all three dimensions and does not get blocked by the walls, floor or ceiling.

For vertical NMR magnet systems the vertical extension is even larger than the horizontal one. High fields will also affect the rooms above and below the magnet.



**Ferromagnetic objects** Strong attraction of ferromagnetic objects may occur at close distances to the magnet, where the magnetic field is above 50 to 100 Gauss. Massive iron objects such as pressurized gas cylinders, are extremely dangerous in the vicinity of a superconducting NMR magnet system. They should be mounted very close to the door and away from the NMR magnet system, or preferably outside the magnet room. Inside the magnet room a wall mounted gas distribution system is recommended.

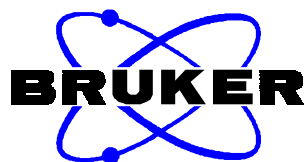

Strayfield	Remarks and recommendations
Below 0.5 mTesla	This region can be opened to the public without restrictions.
Between 0.5 mTesla and 1.0 mTesla	Admission should be forbidden for persons with pace makers and clear warning signs should be fixed on all doors.
Over 1 mTesla	Access must be limited to NMR staff only, by a locked door or by similar means. Admission is clearly forbidden for persons with pace makers and clear warning signs must be fixed on all doors.
Over 5 mTesla	Plastic chains or floor markings should be used to indicate the safety limit for attraction of iron objects.



Note:

**1 mTesla = 10 Gauss**

**Warning signs are delivered with each NMR magnet system.  
Additional signs can be obtained from every Bruker office**

### 5.12 Helium Transfer Line (optional)

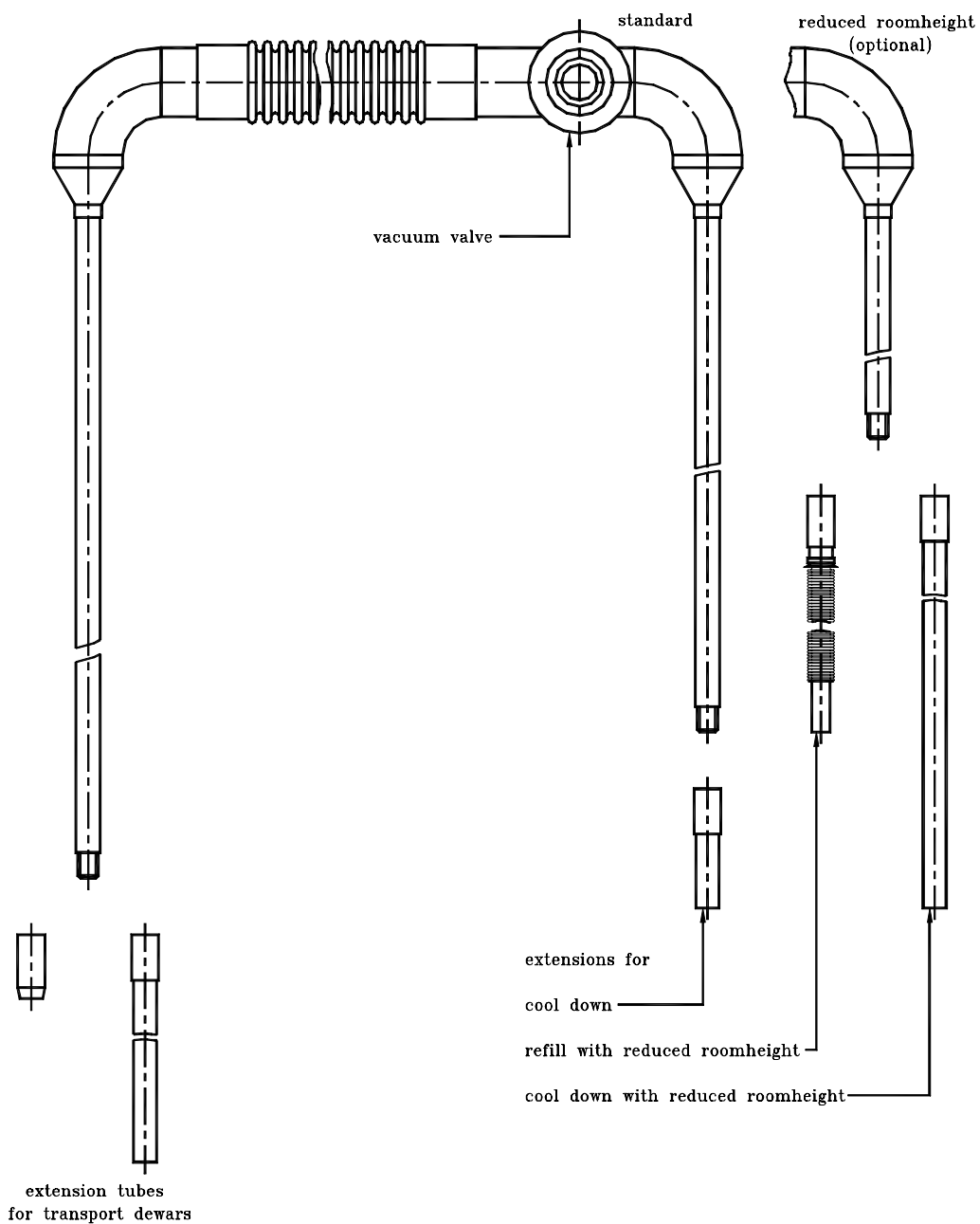

### 5.13 Vacuum Valve KF40 and Drop Off Plate

This dewar is equipped with a permanently mounted vacuum valve with large inner diameter and with a drop off plate for enhanced safety.



**Important**

**Manipulations of the vacuum valve or the drop off plate are absolutely not recommended after system installation. They may lead to a vacuum loss and a subsequent magnet quench. The consequences are not covered by our warranty.**

**Assembly**

1. Do not block or modify the drop off plate.
2. Do not use sticking tape to fix the drop off plate to the dewar plate under vacuum or during warm up.
3. If the vacuum valve has been opened or the vacuum has been accidentally destroyed, do not close the valve or block the drop off plate under any circumstances. This would lead to a dangerous pressure build up in the dewar.

### 5.14 Installation of the Vacuum Valve during Installation of a Magnet System



**No vacuum**

**The following steps have to be carried out if the magnet system is not yet pumped.** (see figure 5.15)

1. Remove the sealing plug from the dewar valve flange.
2. Clean and check the O rings and the sealing surfaces on the valve flange and on the sealing plug.
3. Clean and check the O rings and the sealing surfaces on the valve operator body. The valve operator body is not delivered with the magnet system and is removed after installation.
4. Slightly grease all O rings and sealing surfaces with vacuum grease.
5. Fix the sealing plug on the valve stem and tighten it slightly.
6. Insert the complete vacuum valve into the dewar's valve flange. Be careful not to damage any sealing surface!
7. Turn the valve in the desired position and fix it with the half rings.
8. Check the valve stem to be caught in the outermost position.
9. Connect the pumping unit to the magnet system. Pump and flush the OVC three to four times with dry nitrogen gas.
10. Evacuate the dewar and cool down the whole system. For details see chapters 3 to 5.

11. To close the vacuum valve slightly push the valve stem into the valve operator body until the sealing plug touches the dewar's valve flange. Firmly push the sealing plug into the O ring in the valve flange. The snapping in of the sealing plug is well defined and will be heard and felt! (see figure 5.16)



---

**Closing the vacuum valve**

---

**The vacuum valve can be closed without danger!****Push the valve stem slightly into the valve operator body until the sealing plug touches the dewar's valve flange. Firmly push the sealing plug into the O ring in the valve flange. The snapping in of the sealing plug is well defined and will be heard and felt! (see figure 5.16)**

---

12. Stop pumping. Carefully flood pumping unit and valve operator body with nitrogen gas.
13. Unscrew the valve stem from the sealing plug and carefully pull it out.
14. Remove the valve operator body and check the position of the sealing plug in the valve flange. (see figure 5.15)

**5.15 Vacuum Valve KF40 and Valve Operator Body  
(optional, installation kit only)**

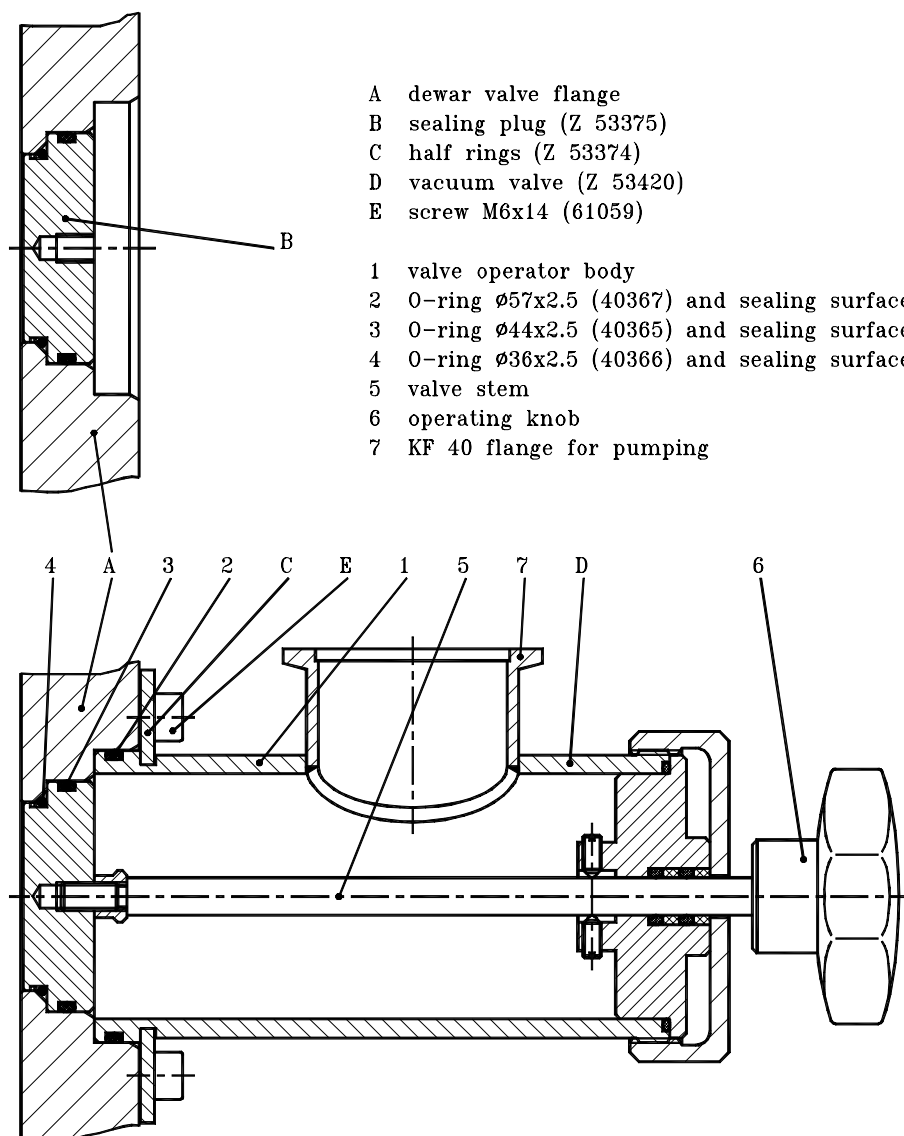

Z4C-29460A



5.16 Vacuum Valve KF40: Operation of the Sealing Plug

sealing plug before snapping in

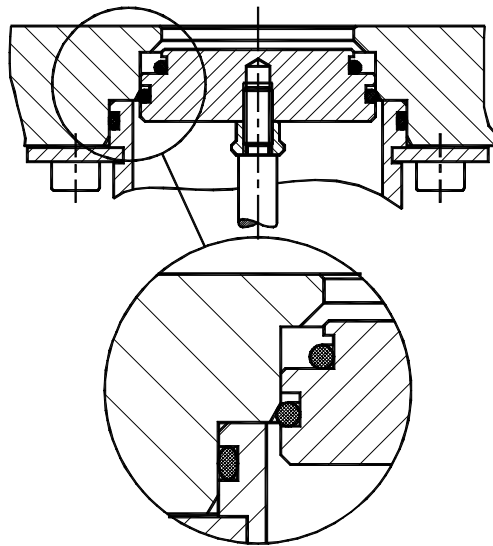

sealing plug inserted completely

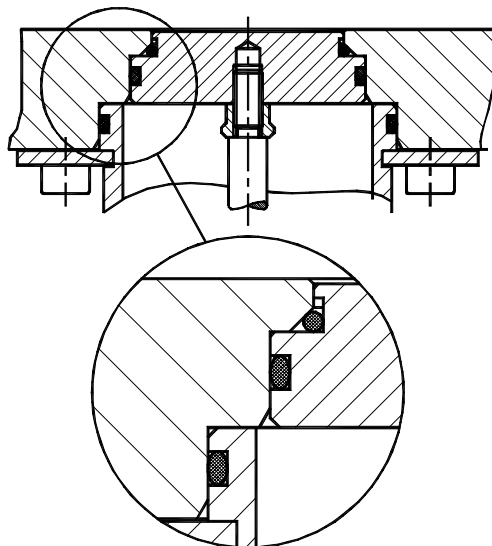

well defined  
snapping in



Z4C-29505A

---

### 5.17 Operation of the Vacuum Valve KF40 to Pump an Evacuated Dewar

---

**Important:**

**The following steps have to be carried out if the magnet system is evacuated and cold.**

For details of construction and operation of the vacuum valve see figures 5.15 and 5.16

**Caution:**

**If pumping on a cold dewar and / or a magnet system on field is needed, the following steps must be carried out only by an experienced Bruker cryogenic engineer.**

**Be sure that the pumping unit may be operated in a stray field as high as found with this magnet system.**

For details refer to the stray field plot in chapter 3!

1. Clean and check the sealing surface on the dewar's valve flange.
2. Clean and check the O rings and the sealing surfaces on the valve operator body. The valve operator body is not delivered with the magnet system and is removed after installation.
3. Slightly grease all O rings and sealing surfaces with vacuum grease.
4. Fix the sealing plug on the valve stem and tighten it slightly.
5. Insert the complete vacuum valve into the dewar's valve flange. Be careful not to damage any sealing surface!
6. Turn the valve in the desired position and fix it with the half rings.
7. Pull the valve stem into the valve operator body until it touches the sealing plug.  
Carefully screw it into the sealing plug.

**Caution:**

**Avoid any strong physical forces on the sealing plug. Tighten the valve stem slightly in the sealing plug.**

8. Connect the pumping unit to the valve operator body. Evacuate the valve operator body and the vacuum tubing to a vacuum better than  $10^{-5}$  mbar.

**Important:**

**Never open the vacuum valve to a cold magnet system with a vacuum worse than  $10^{-5}$  mbar in the vacuum tubing.**

**If the vacuum does not reach  $10^{-5}$  mbar in the tubing, there may be a leak!**

---

9. Carefully pull out the sealing plug with the valve stem. Check the valve stem to be caught in the outermost position.
10. Pump the magnet system as long as necessary.
11. To close the vacuum valve slightly push the valve stem into the valve operator body until the sealing plug touches the dewar's valve flange. Firmly push the sealing plug into the O ring in the valve flange. The snapping in of the sealing plug is well defined and will be heard and felt! (see figure 5.16)



**Closing the vacuum valve**

**The vacuum valve can be closed without danger!**  
**Push the valve stem slightly into the valve operator body until the sealing plug touches the dewar's valve flange. Firmly push the sealing plug into the O ring in the valve flange. The snapping in of the sealing plug is well defined and will be heard and felt! (see figure 5.16)**

12. Stop pumping, carefully flood pumping unit and valve operator body with nitrogen gas.
13. Unscrew the valve stem from the sealing plug and carefully pull it out.
14. Remove the valve operator body and check the position of the sealing plug in the valve flange. (see figure 5.15)

### 5.18 Breaking the Vacuum



**Important:**

**To break the vacuum in the vacuum chamber of the magnet system, proceed in the same way as described in chapter 5.17 to pump an evacuated magnet system.**

1. - 7. Fix the valve operator body to the magnet system as described in chapter 5.17 steps 1. - 7.
8. Connect a vacuum valve and a pumping unit to the valve operator body. Evacuate the vacuum tubing and the valve operator body to a vacuum better than  $10^{-1}$  mbar.
9. Carefully pull out the sealing plug with the valve stem. Check the valve stem to be caught in the outermost position.
10. Close the vacuum valve between magnet system and pumping unit. Stop the vacuum pump.



**Important:**

**To break the vacuum use dry nitrogen gas only!**

11. Break the vacuum very slowly with **dry nitrogen gas** flowing through a needle valve connected to the vacuum valve by an O ring flange **without clamps**.

The gas line is then held in position by the vacuum only. It will drop off automatically once the pressure in the vacuum chamber has reached atmospheric pressure.



---

**Important:**

**Check all nitrogen turrets and the helium manifold to be completely open. There must be a gas flow through these turrets, otherwise they could be blocked with ice!**

---

12. During the first three hours after breaking the vacuum the operator should be present and check repeatedly both the helium boil off as well as the nitrogen boil off: **It may be small, but if no boil off is observed, the corresponding outlets must be checked for icing.**



---

**Warning:**

**Once the vacuum is broken, never reclose the vacuum valve. Strictly avoid any over pressure in the outer vacuum chamber!**

---

---

### 5.19 Vacuum Valve KF25 and Drop Off Plate

---

This dewar is equipped with a permanently mounted vacuum valve with large inner diameter and with a drop off plate for enhanced safety.

Do not abuse the vacuum valve, e.g. as mounting device. Manipulations of the vacuum valve or the drop off plate are absolutely not recommended after system installation. **They may lead to a vacuum loss and a subsequent magnet quench. The consequences are not covered by our warranty.**

#### Assembly

1. Do not block or modify the drop off plate.
2. Do not use sticking tape to fix the drop off plate to the dewar plate under vacuum or during warm up.
3. If the vacuum valve has been opened or the vacuum has been accidentally destroyed, do not close the valve or block the drop off plate under any circumstances. This would lead to a dangerous pressure build up in the dewar.



#### Installation instructions

---

Installation should be carried out by Bruker service engineers. The transport plug must be removed, the vacuum valve inserted and the dewar evacuated.

---

---

## 5.20 Installation of the Vacuum Valve KF25 during Installation of a Magnet System

---



No vacuum

The following steps have to be carried out if the magnet system is not yet pumped.

1. Dismount both half rings and remove the sealing plug from the dewar valve flange.
2. Clean and check the O rings and the sealing surfaces on the valve flange and on the sealing plug.
3. Clean and check the O rings on the valve and the sealing surface on the dewar base plate. Apply a small amount of vacuum grease.
4. Gently insert the vacuum valve. Avoid excessive force, as this may damage the sealing surface.
5. Turn the valve in the desired position and fix it with the half rings.
6. Fix the valve stem with the split tube in the outermost position.
7. Connect the pumping unit to the magnet system. Pump and flush the OVC three to four times with dry nitrogen gas.
8. Evacuate the dewar and cool down the whole system. For details see chapters 3 to 5.
9. Close the vacuum valve by pushing the handle slowly up and turning the red knob clockwise. The sealing force is produced by a spring, so the knob doesn't need to be closed by force.
10. Close the valve with the KF25 sealing cap.

### 5.21 Vacuum Valve KF25 Diagram

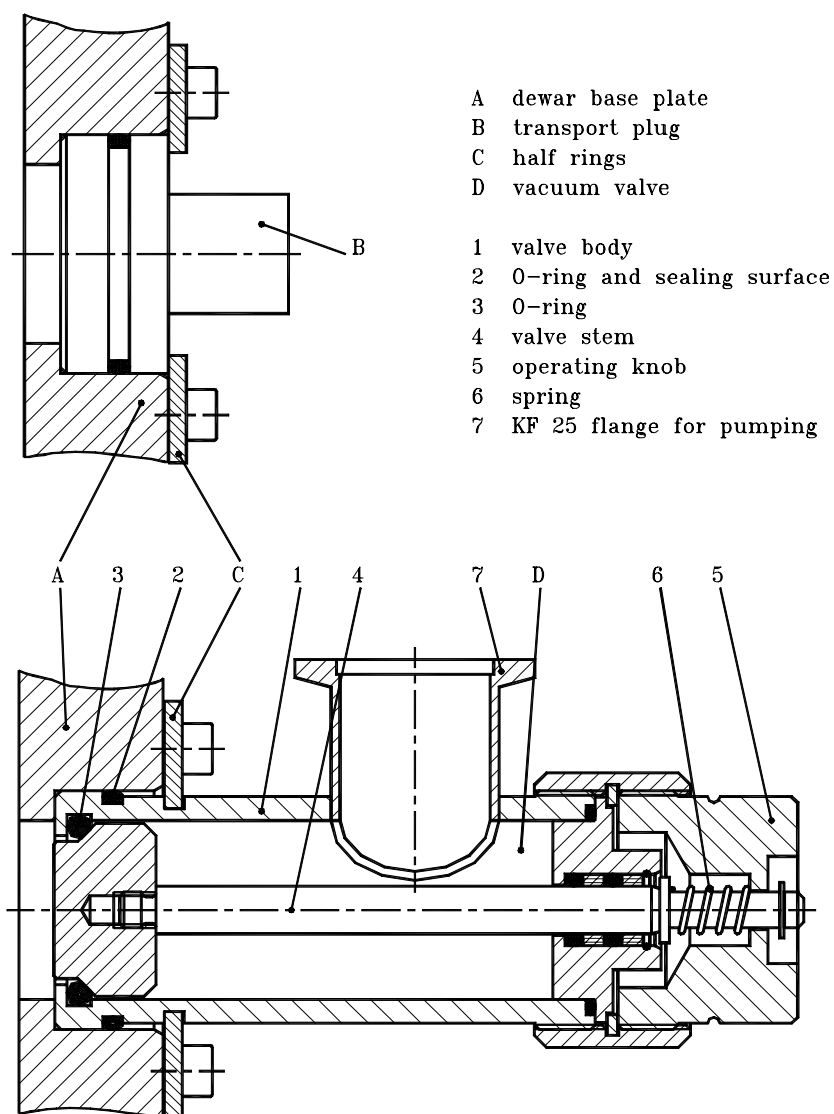

Z4C-3247A

---

## 5.22 Operation of the Vacuum Valve KF25 to Pump an Evacuated Dewar

---

**Important:**

The following steps have to be carried out if the magnet system is evacuated and cold.

For details of construction and operation of the vacuum valve see figure 5.21.

**Caution:**

If pumping on a cold dewar and / or a magnet system on field is needed, the following steps must be carried out only by an experienced Bruker cryogenic engineer.

Be sure that the pumping unit may be operated in a stray field as high as found with this magnet system.

For details refer to the stray field plot in chapter 3!

1. Remove the KF25 sealing cap from the vacuum valve.

**Caution:**

Avoid any strong physical forces on the vacuum valve.

2. Connect the pumping unit to the vacuum valve. Evacuate the vacuum tubing to a vacuum better than  $10^{-5}$  mbar.

**Important:**

Never open the vacuum valve to a cold magnet system with a vacuum worse than  $10^{-5}$  mbar in the vacuum tubing.

If the vacuum does not reach  $10^{-5}$  mbar in the tubing, there may be a leak!

3. Open the vacuum valve by turning the red knob counter clockwise and carefully pulling out the handle.
4. Fix the valve stem with the split tube in the outermost position.
5. Pump the magnet system as long as necessary.
6. Close the vacuum valve by pushing the handle slowly up and turning the red knob clockwise. The sealing force is produced by a spring, so the knob doesn't need to be closed by force.
7. Close the valve with the KF25 sealing cap.



---

### 5.23 Breaking the Vacuum

---

**Important:**

**To break the vacuum in the vacuum chamber of the magnet system, proceed in the same way as described in chapter 5.22 to pump an evacuated magnet system.**

1. Remove the KF25 sealing cap from the vacuum valve.
2. Connect a vacuum valve and a pumping unit to the vacuum valve. Evacuate the vacuum tubing to a vacuum better than  $10^{-1}$  mbar.
3. Open the vacuum valve by turning the red knob counter clockwise and carefully pulling out the handle.
4. Fix the valve stem with the split tube in the outermost position.
5. Close the vacuum valve between magnet system and pumping unit. Stop the vacuum pump.

**Important:**

**To break the vacuum use dry nitrogen gas only!**

6. Break the vacuum very slowly with **dry nitrogen gas** flowing through a needle valve connected to the vacuum valve by an O ring flange **without clamps**.  
The gas line is then held in position by the vacuum only. It will drop off automatically once the pressure in the vacuum chamber has reached atmospheric pressure.

**Important:**

**Check all nitrogen turrets and the helium manifold to be completely open. There must be a gas flow through these turrets, otherwise they could be blocked with ice!**

7. During the first three hours after breaking the vacuum the operator should be present and check repeatedly both the helium boil off as well as the nitrogen boil off: **It may be small, but if no boil off is observed, the corresponding outlets must be checked for icing.**

**Warning:**

**Once the vacuum is broken, never reclose the vacuum valve. Strictly avoid any over pressure in the outer vacuum chamber!**

---

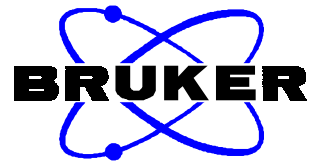

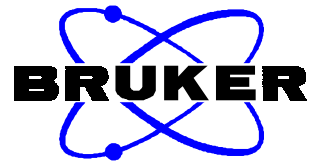

## 6 Integrated Anti Vibration Stand

**Magnet stand**                      The NMR magnet system stand is delivered with a complete anti vibration system. It consists of three active vibration damping columns in massive aluminum pillars.

### 6.1 Operation of the Anti Vibration Stand

**Magnet stand**                      The magnet stand is a very stable mechanical platform for the NMR magnet system and is connected directly to the cryostat's bottom plate.  
The highly sensitive and effective vibration damping columns are integrated in the three pillars of the magnet stand.

**Vibration damping**              Due to sensitive pressure regulation and effective damping mechanisms the vibration damping columns are able to eliminate vibrations down to 2.5 Hertz. So the cryostat is isolated very efficiently from most mechanical disturbances coming from its environment.

### 6.2 Safe Operation of the Anti Vibration Magnet Stand

**Gas supply**                          The anti vibration magnet stand needs dry pressurized air or dry nitrogen gas. For safe operation the pressure must be in the range of 5 bar up to 8 bar (70 psi up to 112 psi).

**Activated Operation**              During standard operation of the NMR magnet system the anti vibration magnet stand may be permanently activated.



**Deactivated Operation**            **Any activities on the NMR magnet system that cause strong vibrations or unusual weight distributions on the anti vibration magnet stand should be done with the anti vibration units deactivated.**

Such activities may be refill of either helium or nitrogen, manipulations at the sample changer and so on.

**Operating Position**                The deactivated as well as the activated operating position are adjusted during installation to make sure, that the NMR magnet system is always operated in its levelled horizontal position.



**Important:**                          **Do not change the adjustment of either the deactivated or the activated operating position after the installation. Malfunction of or damage to the anti vibration magnet stand could result!**

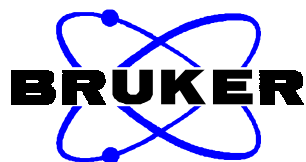

**Vibration damping column**

Every vibration damping column will try to reach the adjusted operating position. If the weight on one column increases, the pressure in the column is increased to reach the operating position again.

**Pressure Loss**

Should the gas supply break down, the anti vibration magnet stand will work normally for some time. There are one way valves within every vibration damping unit that prevent the NMR magnet system from sinking too quickly to the deactivated operating position. Due to small leakage the NMR magnet system will slowly sink to the deactivated operating position.

---

### 6.3 Moving the NMR Magnet System After Installation

---



**Warning:**

**Do never try to move the 700 MHz NMR magnet system after the installation!**

**Damage to or even destruction of the NMR magnet system due to insufficient stability for transportation without transport fixture could result!**

---

### 6.4 Assembly of the Anti Vibration Stand

1. Lift the magnet system with the crane at least 740 mm above the floor.
2. Attach the three pillars to the bottom plate of the hanging cryostat with two M 10x50 mm screws each.



**Orientation**

**Make sure the pillars are oriented correctly with the screws and the positioning bolt. The air controller must be in the rear pillar!**

3. Fix the two hollow pillar braces to the anti vibration units.
4. Adjust the outer screw feet to be about 10 mm (0.4 inches) shorter than the central screw feet. (see figure 6.8)
5. Lower the NMR magnet system at its final place of operation.
6. Level the complete NMR magnet system carefully with the three central screw feet. Use the cryostat flange as the reference surface for the levelling. (see figure 6.8)
7. Lower the three outer screw feet in every pillar until they are loaded equally. (see figure 6.9)



**Important:**

**Make sure that the levelling of the magnet system is not changed when the outer screw feet are loaded!  
The outer screw feet make sure that the three pillars are standing perfectly stabilized on the floor.**

8. Secure the outer screw feet with the securing nuts.
9. Loosen the transport fixtures of the vibration damping columns. The fixture consists of two screws in the top plate and of a third screw on the rear side of each vibration damping column. The third screw is located in the aluminum support that is holding the pillar braces. (see figure 6.6 and 6.7)



**Important:**

**Do not activate the vibration damping columns before the NMR magnet system is at its definitive place of operation and before it is levelled correctly on the magnet stand!**

10. Insert the pneumatic tubings into the hollow pillar braces and connect them to the vibration damping columns. (see figure 6.7, 6.9 and 6.11)



**Important:**

**Do not bend the pneumatic tubings in the magnet stand too sharply!**

### 6.5 Adjustment of the Vibration Damping Columns

1. Check the regulation valves of the vibration damping columns. **They must have free play.**



**Important:** The regulation arms must touch the bottom plate of the cryostat. They must have free play.

**Adjusting screws** 2. Check the length of the adjusting screws in the bars that are operating the regulation valves.  
The bars must be adjusted to be in a more or less horizontal position.

**Pneumatics** 3. Connect the vibration damping columns with the operation control switch and with the pressurized air or nitrogen gas supply. (see figures 6.10 and 6.11)

4. Activate the anti vibration columns.



**Important:** When the NMR magnet system has reached the operating position it must be levelled carefully!

**Alignment** 5. To do this, adjust the screws that operate the regulation valves by touching the bottom plate of the cryostat. (see figure 6.12)

**Levelling** 6. The reference surface for the levelling is the cryostat flange. In the correct operating position there must be a vertical free play of about 5 mm (0.2 inches) on all three pillars (see figure 6.11 and 6.12).

**Securing nuts** 7. Secure the adjusting screws with the nuts.



**Caution:** The anti vibration magnet stand will only work correctly if the levelling procedure in the deactivated as well as in the activated operating position are done carefully!



**Important:** Strictly follow these directions step by step. Otherwise malfunction of the anti vibration magnet stand or damage to the vibration damping columns will occur!

### 6.6 Function control of the Anti Vibration Magnet Stand

**Deactivated Operation**

1. Deactivate the vibration damping columns. Verify the levelling of the NMR magnet system.

**Activated Operation**

2. Activate the vibration damping columns. Check the pneumatic tubing for leakage. Check that the NMR magnet system may play vertically without any touching or scratching.
3. Verify the levelling of the NMR magnet system.
4. Check the vertical free play of about 5 mm (2 inches) on all three pillars.



**Important:**

**There must not be any touching or scratching between the cryostat and the pistons!**

5. Mount all the cover panels and the three protection covers.

### 6.7 Disassembly of the Anti Vibration Magnet Stand

1. Remove the covers from the pillars.
2. Deactivate the vibration damping columns. Release the pressurized gas.
3. Secure every antivibration unit with the three securing screws. These three screws are the transport fixture of each pillar. (see figures 6.6 and 6.7)
4. Loosen the two screws that fix the pillars to the cryostat. (see figure 6.7)
5. Lift up the cryostat with a crane.
6. Disconnect the pneumatic tubing. Remove the pillar braces.



**Important:**

**Leave the vibration damping columns and the pillars connected for transportation!**

7. Place the cryostat onto the assembling feet.



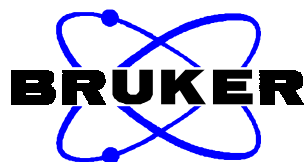

## 7 Trouble Shooting

### 7.1 Trouble shooting during Assembly

Problem indicators	Possible reasons	Solutions
Tilt indicators and/or shock watches are broken.	Uncareful transportation or transportation accident.	Contact shipping agent, check the whole magnet system for damages.
Visible damages.	Uncareful transportation.	Contact shipping agent, check all tilt indicators and shock watches.
Ceiling height too low for assembly on magnet stand.		Do the assembly on the assembling feet.
Ceiling height too low for exchange of helium level sensor.		Insert helium level sensor while magnet system is on the assembling feet.
He vessel and N <sub>2</sub> vessel are not concentric.	Alignment is not done correctly.	Repeat the alignment of the He vessel and the N <sub>2</sub> vessel.
	Alignment rod is lose.	Check fixation of the alignment rods.
	Alignment rod is broken.	Replace defective alignment rod.
	Reduction flanges may be non concentric.	Check orientation of the non concentric reduction flange.
N <sub>2</sub> vessel and OVC are not concentric.	Reduction flanges may be non concentric.	Repeat alignment of the N <sub>2</sub> vessel and the OVC.
Vacuum in OVC does not reach 10 <sup>-5</sup> mbar within 48 hours.	O rings may be leaky	Check vacuum tubing to the vacuum pump. Check O rings in the vacuum valve. Check O rings and sealing surfaces on reduction flanges and on sealing flanges. Check O ring and sealing surfaces of the drop off plate.

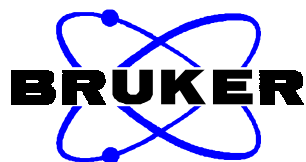

<b>Problem indicators</b>	<b>Possible reasons</b>	<b>Solutions</b>
Vacuum in OVC does not reach $10^{-5}$ mbar within 48 hours.	Room temperature bore tube has scratches or dust on the sealing surfaces.	Check sealing surfaces on the room temperature bore tube: No scratches and no dust must be visible!
	Moisture may have entered the OVC during transportation or during assembly.	Pump and flush the OVC several times with dry nitrogen gas to remove moisture.
	Pump stand is defective and does not reach the required vacuum of $10^{-6}$ mbar.	Check pump stand. Pumping directly against a sealing cap produces pressure below $10^{-6}$ mbar.
Upper pillar brace collides with vacuum valve.	Vacuum valve is not orientates parallel to the pillar brace.	Turn the vacuum valve until the flange does not collide with the pillar brace any more. This operation may be carefully done with evacuated OVC.
Superisolation touches OVC or radiation shield or bore tubes.	Superisolation was not fixed correctly during assembly.	Fix the superisolation on the $N_2$ vessel properly with the supplied polyester tape. Avoid any connection between different vessels or bore tubes in the cryostat carefully!

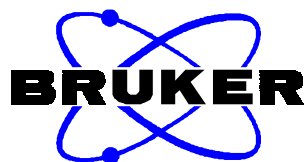

## 7.2 Trouble shooting during Cool Down Procedure

Problem indicators	Possible reasons	Solutions
Precooling with liquid nitrogen proceeds too slowly.	Transport dewar for liquid nitrogen is empty.	Refill transport dewar.
	Transfer pressure is too low.	Increase transfer pressure.
	Transport dewar is leaky, no transfer pressure may be applied.	Check transport dewar for leakage and seal gas supply tubing.
Precooling with liquid nitrogen proceeds too fast.	Transfer pressure is too high.	Immediately stop precooling and adjust transfer pressure properly.
	Large coils must be pre-cooled with ACD* (Automatic Cooling Device).	Connect ACD* correctly to the NMR magnet system for cool down procedure.
Vacuum in OVC does not reach $10^{-6}$ mbar during pre-cooling.	O rings may be leaky.	Stop precooling and warm up the NMR magnet system. Check vacuum tubing to vacuum pump. Check O rings in the vacuum valve. Check O rings and sealing surfaces on reduction flanges and on sealing flanges. Check O ring and sealing surfaces of the drop off plate.
	O ring is frozen due to contact with liquid nitrogen.	Immediately stop transferring liquid nitrogen. Warm up O ring with warm air! Wait until vacuum recovers and prevent liquid nitrogen from splashing on O rings.
	Pump stand is defective and does not reach the required vacuum of $10^{-6}$ mbar.	Check pump stand. Pumping directly against a sealing cap produces pressure below $10^{-6}$ mbar.

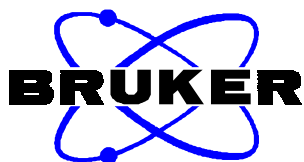

Problem indicators	Possible reasons	Solutions
The OVC becomes cold and wet.	Pumping was stopped. Vacuum is broken or worse than $10^{-3}$ mbar.	Do not remove the pumping unit until collection of liquid helium starts in the helium vessel! Find reason of vacuum problem (O ring, pump, frozen O ring) and proceed following the points mentioned there.
	Cold leak after transportation (transportation damage).	Contact Bruker for further help.
Room temperature bore tube shows cold spot (condensing or freezing moisture on the bore tube).	Room temperature bore tube and N <sub>2</sub> bore are not aligned correctly and are touching each other.	Stop the cool down procedure. Warm up the system and repeat the alignment.
No liquid nitrogen is found when starting to pump back liquid nitrogen after pre-cooling.	The precooling L-tube is not inserted completely into the syphon.	Insert the L-tube completely into the syphon.
	The precooling L-tube is not tight in the syphon.	Check the lower end of the precooling L-tube for deformations and spread it slightly to fit into the syphon.
	No liquid nitrogen is collected into the helium vessel.	Check with the dipstick, to be sure that the helium vessel is completely empty of liquid nitrogen and of frozen nitrogen! (nitrogen ice).
The helium manifold becomes very cold and icy during pumping while pumping and flushing.	There is remaining liquid nitrogen in the helium vessel, boiling off strongly during pumping.	Stop pumping immediately and carefully remove all liquid nitrogen through the L-tube. Check with the dipstick to be sure that the helium vessel is completely empty of liquid nitrogen and of frozen nitrogen! (nitrogen ice).

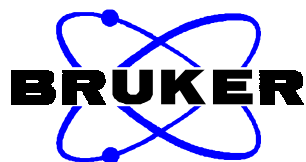

Problem indicators	Possible reasons	Solutions
<p>After some intervals of pumping and flushing it is not possible to reach a vacuum in the range of 1 mbar.</p>	<p>The spheres in the quench valves are not sitting correctly in the O rings and thus the quench valves are leaky.</p>	<p>Immediately stop pumping. Remove frozen air and frozen moisture with warm helium gas. Make tight the quench valves by slightly greasing the O rings and checking the position of the spheres. Check with the dipstick to be sure that the helium vessel is completely empty of liquid nitrogen and of frozen nitrogen! (nitrogen ice).</p>
	<p>There is remaining liquid nitrogen in the helium vessel, boiling off strongly during pumping.</p>	<p>Stop pumping immediately and carefully remove all liquid nitrogen through the L-tube. Check with the dipstick to be sure that the helium vessel is completely empty of liquid nitrogen and of frozen nitrogen! (nitrogen ice).</p>
<p>Frozen nitrogen (nitrogen ice) is found in the helium vessel.</p>	<p>Pumping intervals during pumping and flushing were too long and remaining nitrogen was boiling off and then freezing.</p>	<p>Warm up the magnet coil with warm helium gas through the L-tube and the syphon until the whole coil is warmer than 90° Kelvin. Check the temperature of the coil with the ACD*. Repeat pumping and flushing and carefully check with the dipstick to be sure that the helium vessel is completely empty of liquid nitrogen and of frozen nitrogen! (nitrogen ice).</p>
<p>The transfer of liquid helium does not start.</p>	<p>The transfer pressure in the transport dewar is too low.</p>	<p>Increase the transfer pressure.</p>
	<p>The transfer dewar is leaky, there is no transfer pressure built up.</p>	<p>Check transport dewar for leakage. Make all connections tight.</p>

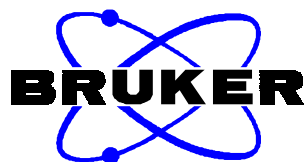

Problem indicators	Possible reasons	Solutions
	The transport dewar is empty.	Use new transport dewar.
	The syphon or the helium transfer line are blocked with ice.	Check syphon and transfer line for blockages, remove ice with warm helium gas.
The cool down of the magnet coil does not proceed although helium is transferred from the transport dewar into the cryostat.	The helium transfer line may be defective.	Check the helium transfer line for icing. If there are cold spots visible, replace the transfer line.
	The extension is not mounted on the transfer line. The liquid helium is not forced to flow through the syphon down to the bottom of the helium vessel.	Mount the extension piece on the transfer line. Check the helium transfer line to be inserted completely into the syphon.
The zero reading of the helium level meter can not be adjusted at the beginning of the cool down with liquid helium.	The level sensor is not connected properly with the connector in the helium manifold.	Check the connection in the helium turret between level sensor and connector.
	The level meter is defective.	Check the level meter with the 0% calibration plug.
The helium level never reaches 100% after the cool down.	The transport dewar is empty, no more helium is transferred into the cryostat.	Use new transport dewar.
	The levelsensor is disturbed by the transfer line's extension piece.	Stop transferring helium. Remove the transfer line and measure the helium level after some minutes without transfer line.
	The final filling should not be done through the syphon. The helium in the vessel is disturbed too much.	Use for final filling and for refilling of the cryostat the helium transfer line <b>without</b> extension piece.

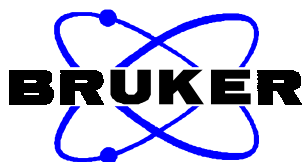

Problem indicators	Possible reasons	Solutions
The OVC becomes wet and cold.	Pumping was stopped. Vacuum is broken or worse than $10^{-3}$ mbar.	Do not remove the pumping unit until collection of liquid helium starts in the helium vessel! Find reason of vacuum problem (O ring, pump, frozen O ring) and proceed following the points mentioned there.
	Cold leak after transportation. (transportation damage)	Contact Bruker for further help.
Room temperature bore tube shows cold spot (condensing or freezing moisture on the bore tube).	Room temperature bore tube and N <sub>2</sub> bore are not aligned (correctly and are touching each other).	Stop the cool down procedure. Warm up the system and repeat the alignment.
After cool down the helium boil off is higher than specified. (up to 5 times)	Normal behaviour. The radiation shields and the insulation need some days to reach final low temperatures.	Wait some days and super- vise helium boil off. The presence of the current lead in the left helium turret during charging and shimming helps to cool down the radiation shield.
After cool down the nitrogen boil off is zero.	The nitrogen security flow system has not been mounted correctly during the cool down with helium. Due to supercooling of the nitrogen vessel during cool down with helium, air was sucked into the N <sub>2</sub> vessel and ice is blocking the N <sub>2</sub> turrets.	Immediately check the nitrogen turrets for the presence of ice and remove the ice with warm helium gas!

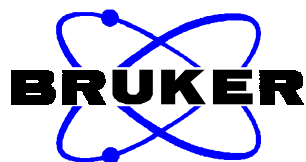

**7.3 Trouble shooting during Charging and Shimming**

<b>Problem indicators</b>	<b>Possible reasons</b>	<b>Solutions</b>
The current lead can not be inserted completely into the connector.	The connector is covered with ice. (frozen moisture or frozen nitrogen)	Carefully remove the ice with warm helium gas. To remove little ice spots use the dipstick as tubing for the warm helium gas.
	The shorting plug was not removed after cool down.	Remove the shorting plug with the extraction rod.
	The orientation of the current lead is not correct.	Turn the current lead carefully until it can be inserted correctly into the connector.
The shim heaters and/or the main heater can not be activated with the cryo power supply.	The current lead is not inserted correctly into the connector.	Turn the current lead carefully until it can be inserted correctly into the connector.
	The connector is covered with ice. (frozen moisture or frozen nitrogen)	Carefully remove the ice with warm helium gas. To remove little ice spots use the dipstick as tubing for the warm helium gas.
	The connectors "A" and "B" of the control cable are mismatched on the current lead's connectors.	Connect the control cable correctly to the current lead. See figures in chapter 3 for details of the current lead.
With closed main heater it is not possible to do the 100 A (120 A) test with the cryo power supply.	The main current cable is not connected properly to the current lead and/or the cryo power supply.	Connect the main current cable correctly to the current lead and the cryo power supply.
	The switch "Main Coil/OFF/Shim Coil" is not put on the "Main Coil" position.	Put the switch on the "Main Coil" position.



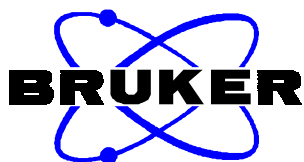

Problem indicators	Possible reasons	Solutions
With closed main heater it is not possible to do the 100 A (120 A) test with the cryo power supply.	The main current contacts on the current lead and/or the main current cable are oxidated and thus have too high resistance.	Clean main current contacts carefully. Connect current lead and main current cable correctly.
	The cryo power supply and/or the main current cable are defective.	Check the cryo power supply and the main current cable with a short circuit plug.
The sense voltage can not be set correctly to charge the magnet.	The main heater switch is set to the "OFF" position. The main switch is not opened.	Put the main heater switch to the "ON" position and check the main heater current to be adjusted correctly.
	The main heater current is set too low. The main switch is not opened.	Adjust main heater current correctly. See chapter 3.1 for specified values.
	The auxiliary shorting plug is inserted in the right helium turret and makes a short circuit across the main coil.	Remove the auxiliary shorting plug.
	600 MHz systems: The 22 pin shorting plug is inserted in the rear helium turret and makes a short circuit across the main coil.	Remove the 22 pin shorting plug.
The magnet quenches during charging.	Happens sometimes, caused by internal stress during charging.	Repeat cool down with helium within an hour after the quench. Wait the indicated time before charging the magnet again. For details see chapters 3 and 4 in the manual.
	The helium level was too low for charging.	Never try to charge the magnet with less than the minimum allowed level in the helium vessel. See chapter 3 for details.

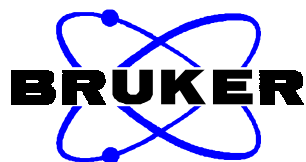

Problem indicators	Possible reasons	Solutions
The magnet quenches during charging.	The cryo power supply is defective! The main current is oscillating.	Replace cryo power supply.
The main coil switch can not be closed on field.	The helium level is too low for charging. The main coil switch is not covered with liquid helium.	Never try to charge the magnet with less than the minimum allowed level in the helium vessel. See chapter 3 for details.
	The cryo power supply is defective! The main current is oscillating.	Replace cryo power supply.
The shim current can not be set correctly.	The control cable is not connected correctly to the current lead and/or the cryo power supply.	Correctly connect the control cable to the current lead and to the cryo power supply.
	The switch "Main Coil/OFF/Shim Coil" is not put on the "Shim Coil" position.	Put the switch "Main Coil/OFF/Shim Coil" on the "Shim Coil" position.
The shim current stops at approximately 80 mA and can not be set to a higher value	"A" and "B" connectors of the control cable are mismatched on the current lead. <b>Caution:</b> The shim current flows through the main heater and will open it!	Immediately check whether the magnet is in the persistent mode anymore. If not, immediately prepare the main current cable and put the cryo power supply in the "Main Coil" mode. Recharge the magnet and make it persistent on the correct field!
The shims have no effect on the NMR signal.	The shim heater current is set too low. The shim switches are not opened.	Set the shim heater current to the specified value according to chapter 3.

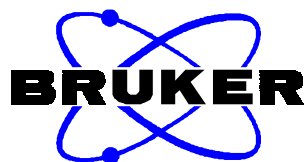

Problem indicators	Possible reasons	Solutions
The magnet can not be shimmed to reach specifications again.	There is some magnetic material in the room temperature bore tube (bostich, iron chip, rusty dust or similar).	Carefully clean the room temperature bore tube with a wet kleenex. <b>Caution:</b> Magnetic chips will be strongly attracted and will be drawn to the magnetic center. Try to wrap them up with the kleenex at the end of the bore tube!
	Massiv ferromagnetic parts are in the vicinity of the magnet that are strongly influencing the magnet.	Keep maximum possible distance between magnet and ferromagnetic parts. Repeat cryoshimming, starting with the low order shims and the values stated in chapter 3.1 of the manual.
The shimming procedure produces irreversible field shift.	Normal behaviour with 600 MHz systems.	Charge the magnet to a higher (lower) field as stated in chapter 3. The $Z^2$ -shift consists of the values of the $Z^2$ -shim itself and the effects of shimming.

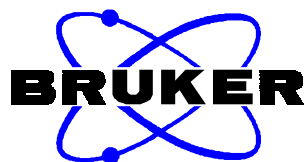

### 7.4 Trouble shooting during Standard Operation

Problem indicators	Possible reasons	Solutions
The N <sub>2</sub> boil off falls to zero.	The N <sub>2</sub> neck tubes are blocked with ice.	Remove the heat exchangers and remove the frozen moisture. Check the O rings in the heat exchangers and mount them correctly on the N <sub>2</sub> turrets.
	During refill of helium supercooling of the N <sub>2</sub> vessel leads to reduced boil off.	Check some hours after the refill of helium, that there is normal N <sub>2</sub> boil off. Otherwise remove ice as described above.
	The N <sub>2</sub> vessel is empty.	Immediately refill the N <sub>2</sub> vessel. Keep a filling record. For specified hold time see chapter 4.
The helium boil off falls to zero.	The atmospheric pressure is increasing.	Normal behaviour, watch helium boil off daily.
	The He neck tubes are blocked with ice.	Immediately call a Bruker service engineer. <b>Do not try to remove ice in the helium turrets without special knowledge!</b>
The helium boil off is too high.	The helium level meter is permanently on (service mode) or used frequently.	Measure the helium level once a week or less. Keep a helium level record. Every measuring of the helium level incorporates some helium losses due to the heating of the sensor.
	The atmospheric pressure is decreasing.	Normal behaviour. The Electronic Atmospheric Pressure Device (EAPD) is able to stabilize the pressure in the helium vessel within 0,1 mbar. (optional)

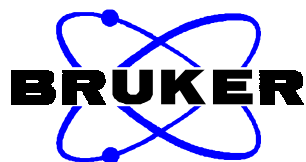

Problem indicators	Possible reasons	Solutions
The helium boil off is too high.	The pressure in the helium vessel is increasing due to blocked helium neck tubes or blocked helium manifold.	Immediately check helium boil off. If the helium neck tubes are blocked immediately call a Bruker service engineer. <b>Do not try to remove ice in the helium turrets without special knowledge!</b>
	The radiation baffles are not inserted in the helium turrets.	Insert the radiation baffles into the left (and rear) helium turret.
	The helium oscillation damper is not mounted on the left helium neck tube.	Mount the helium oscillation damper on the left helium neck tube.
The NMR spectrum shows strong vibrations at approximately 43 Hz.	The helium oscillation damper is not mounted on the left helium neck tube.	Mount the helium oscillation damper on the left helium neck tube.

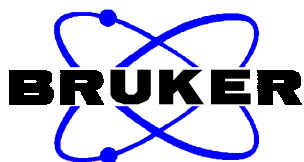

**7.5 Trouble shooting during Discharging and Warm up**

<b>Problem indicators</b>	<b>Possible reasons</b>	<b>Solutions</b>
The shorting plug cannot be removed from its place.	The connectors are covered with ice.	Carefully remove the ice with warm helium gas. To remove little ice spots use the dipstick as tubing for the warm helium gas.
The current lead can not be inserted completely into the connector.	The connector is covered with ice. (frozen moisture or frozen nitrogen)	Carefully remove the ice with warm helium gas. To remove little ice spots use the dipstick as tubing for the warm helium gas.
	The shorting plug was not removed.	Remove the shorting plug with the extraction rod.
	The orientation of the current lead is not correct.	Turn the current lead carefully until it can be inserted correctly into the connector.
The shim heaters and/or the main heater can not be activated with the cryo power supply.	The current lead is not inserted correctly into the connector.	Turn the current lead carefully until it can be inserted correctly into the connector.
	The connector is covered with ice. (frozen moisture or frozen nitrogen)	Carefully remove the ice with warm helium gas. To remove little ice spots use the dipstick as tubing for the warm helium gas.
	The connectors "A" and "B" of the control cable are mismatched on the current lead's connectors.	Connect the control cable correctly to the current lead. See figures in chapter 3 for details of the current lead.
With closed main heater it is not possible to do the 100 A (120 A) test with the cryo power supply.	The main current cable is not connected properly to the current lead and/or the cryo power supply.	Connect the main current cable correctly to the current lead and the cryo power supply.

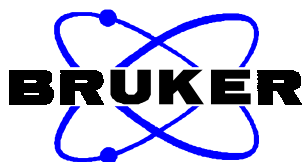

Problem indicators	Possible reasons	Solutions
With closed main heater it is not possible to do the 100 A (120 A) test with the cryo power supply.	The switch "Main Coil/OFF/Shim Coil" is not put on the "Main Coil" position.	Put the switch on the "Main Coil" position.
	The main current contacts on the current lead and/or the main current cable are oxidated and thus have too high resistance.	Clean main current contacts carefully. Connect current lead and main current cable correctly.
	The cryo power supply and/or the main current cable are defective.	Check the cryo power supply and the main current cable with a short circuit plug.
The sense voltage can not be set correctly to charge the magnet.	The main heater switch is set to the "OFF" position. The main switch is not opened.	Put the main heater switch to the "ON" position and check the main heater current to be adjusted correctly.
	The main heater current is set too low. The main switch is not opened.	Adjust main heater current correctly. See chapter 3.1 for specified values.
	The auxiliary shorting plug is inserted in the right helium turret and makes a short circuit across the main coil.	Remove the auxiliary shorting plug.
	600 MHz systems: The 22 pin shorting plug is inserted in the rear helium turret and makes a short circuit across the main coil.	Remove the 22 pin shorting plug.
The magnet quenches during charging.	The helium level was too low for charging.	Never try to charge the magnet with less than the minimum allowed level in the helium vessel. See chapter 3 for details.
	The cryo power supply is defective! The main current is oscillating.	Replace cryo power supply.

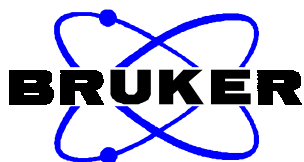

Problem indicators	Possible reasons	Solutions
The shim current can not be set correctly.	The control cable is not connected correctly to the current lead and/or the cryo power supply.	Correctly connect the control cable to the current lead and to the cryo power supply.
	The switch "Main Coil/OFF/Shim Coil" is not put on the "Shim Coil" position.	Put the switch "Main Coil/OFF/Shim Coil" on the "Shim Coil" position.
The nitrogen boil off is zero after the discharging of the magnet.	Due to supercooling of nitrogen air was sucked into the nitrogen vessel and frozen moisture blocks the nitrogen turrets.	Remove the ice from the nitrogen turrets.
After breaking the vacuum with nitrogen with a needle valve, the helium and nitrogen boil off are very high.	The liquid cryogenes have not been removed from the vessels before breaking the vacuum.	Blow out the liquid helium with warm helium gas blown through the L-tube into the syphon. Blow out the liquid nitrogen into a transport dewar.
The vacuum is not broken completely after 12 hours.	The vacuum valve has closed itself due to pressure differences.	Block the operator of the vacuum valve with the split plastic tube.
The room temperature bore tube is wet and cold before disassembly of the dewar.	The magnet coil has not yet warmed up completely.	<b>Wait one more day.</b> Never open a dewar before the room temperature bore tube is warm and dry!



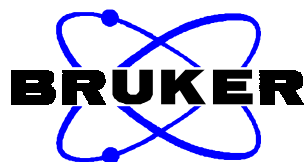

### 7.6 Trouble shooting of the Anti Vibration Magnet Stand

Problem indicators	Possible reasons	Solutions
The anti vibration magnet stand does not reach the operating position.	The air controller is on the "DOWN" position.	Put the air controller to the "UP" position.
	The pressure of the gas supply is too low.	Check the pressure of the gas supply. It must be in the range of 5 bar to 8 bar (70 psi to 112 psi).
	The pneumatic tubings or connectors are leaky.	Check the pneumatic tubings and connectors for leakage.
	The NMR magnet system is not leveled correctly.	Deactivate the anti vibration units or the vibration dampers. Check the leveling of the cryostat as described in chapter 6.
	The operating position is not leveled correctly.	Activate the anti vibration units or the vibration dampers. Check the leveling of the cryostat as described in chapter 6. Contact a Bruker service engineer to repeat the leveling of the NMR magnet system if necessary.
	A level valve is defective.	Contact a Bruker service engineer to exchange the defective level valve..
	The membrane of a vibration damping unit is defective.	Contact a Bruker service engineer to repair or exchange the defective vibration damping unit.
The NMR spectrum shows massive vibrations.	The air controller is on the "DOWN" position.	Put the air controller to the "UP" position.

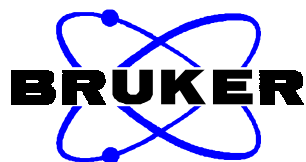

Problem indicators	Possible reasons	Solutions
	The vibration dampers are pumped to strongly. The damping efficiency is reduced.	Check the pressure in the vibration dampers. Adjust the pressure as described in chapter 6.
	The cryostat can not play freely in the operating position. The dewar has direct mechanical contact with the floor.	Check the leveling of the NMR magnet system with deactivated as well as with activated vibration damping units. With activated vibration damping units no scratching or touching between cryostat and magnet stand is observed.
	The dewar has direct mechanical contact with the floor.	Check that no direct mechanical contact between cryostat and floor is produced by any accessory close to the NMR magnet system.

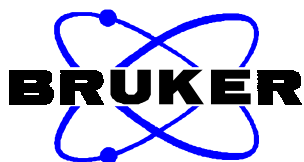

---

## 8 Appendices

---

### 8.1 Packing List

---

**Unpacking** Please check the following packing list carefully before installation of your NMR magnet system.

### 8.2 Options

---

**Accessories** Please remind, that the list of optionally available accessories may have changed since the installation of the NMR magnet system. Please contact Bruker for current information.

### 8.3 Printed Forms

---

**Function Control** This form may be used to record the measured resistances of the magnet coil before the installation at room temperature and after the cool down procedure.

**Charging Record** This form is used to record the charging of the magnet coil.

**Refill Record** This form should be used to record the helium level and the nitrogen level. Please use it also to record the refills of liquid helium and of liquid nitrogen.

**Helium Boil Off** This form may be used if gas counters are installed to measure the helium boil off. The factor of 1430 is exact with an average atmospheric pressure of 965 mbar and an average room temperature of 20°C.

**Nitrogen Boil Off** This form may be used if gas counters are installed to measure the nitrogen boil off. The factor of 1414 is exact with an average atmospheric pressure of 965 mbar and an average room temperature of 20°C.

