

Frequency System

SE451-3CH

Technical Manual

Version 004

BRUKER

The information in this manual may be altered without notice.

BRUKER accepts no responsibility for actions taken as a result of use of this manual. BRUKER accepts no liability for any mistakes contained in the manual, leading to coincidental damage, whether during installation or operation of the instrument. Unauthorised reproduction of manual contents, without written permission from the publishers, or translation into another language, either in full or in part, is forbidden.

This Manual was written by

S.Leemann, Ch.Schumacher, F.Althaus

Spectrospin AG, CH-8117 Fällanden

©November 5, 1994 - Spectrospin AG

Fällanden, Switzerland

Updated for BASH 2.0 by U. Roos - December 1996

P/N: Z31243
DWG-Nr.: 914 004

Contents

	Index	5
1	SE451 3-CHANNEL	7
1.1	Features	7
1.2	General Description	7
1.3	Block Diagram	7
	Frequency Generation Function Diagram	9
1.4	Receiver Gain	9
	Receiver Gain calculation	9
	Receiver Gain Table	10
2	Connectors and Signals	11
2.1	General	11
2.2	Burndy1 connector (SE451 Control)	11
2.3	Burndy2 connector (4Phase Modulator Control)	13
2.4	25 Sub-D Connector (male, RXC-Control)	13
2.5	SMA and BNC connectors	14
2.6	Alternativ signal names	15
2.7	ext. Fan Supply connector	16
3	Motherboard Z4P2997	17
3.1	General	17
3.2	Block diagram LO-switch	17
4	PAL Equations	19
4.1	General	19
4.2	Jumpers	19
	Factory configuration	20
	Jumper settings for other configurations	20
	Detailed jumper description:	21
4.3	PAL inputs and outputs	22
4.4	PAL equations	23
4.5	PAL: PLCC Pin Connections	24
5	4Phase Modulator	25
5.1	General	25
5.2	Block Diagram of 4Phase Modulator RF Board (RF part only)	25
5.3	Block diagram and function description of a QPSK-modulator	26
5.4	Function description of the 4Phase Modulator	27
6	Temperature Controller	29
6.1	General	29
6.2	Function description	29
6.3	Operation	29

	Operating point adjustment index Z4P3032	30
	Operating point adjustment index A and higher	30
6.4	LED descriptions	30
	LED green: +19V	30
	LED red: ERROR	31
	LED red: Not Adjusted (Z4P3032A and higher only)	31
6.5	External fan supply	31
6.6	External fan supply monitor	31
7	BBIS for SE451-3CH	33
7.1	General	33
7.2	Block / page description	33
	BBIS production page	33
	BBIS service page	34
	BBIS device block	35
	BBIS application block	36
8	Technical Data	37
8.1	General Specifications	37
8.2	Power Supply (including 4Phase Modulator)	37
8.3	Warm-up time constant	38
8.4	Pulse Propagation Delay (Motherboard only)	38
8.5	Receiver Gain Table	38
9	ECL Information	39
10	Y-Cable Z12621	41
10.1	General	41
10.2	Operation of SE451-3CH with Y-cable	41
10.3	Wiring of the Y-cable	41
11	Schematics Motherboard	45
11.1	Schematics and Assembly	45
12	Schematics BBIS Board	55
12.1	Schematics and Assembly	56
13	Schematics Temp. Contr.	61
13.1	Schematics and Assembly	62
14	Schematics Receiver Board	67
14.1	Schematics and Assembly	67
15	Schematics LO-Board II	81
15.1	Schematics and Assembly	81
	List of Figures	97
	List of Tables	99

Index

Zahlen

	4Phase Modulator.....	17
	4Phase Modulator control board	25
	4Phase Modulator RF board	13, 25
A	acquisition rack (AQR)	25
	AQR	25
B	BBIS	33
	BBIS application block	36
	BBIS device block.....	35
	BBIS production page.....	33
	BBIS service page	34
	block diagram	7
	Burndy connectors.....	11, 41
	Burndy1 connector	11, 41
	Burndy2 connector	13, 25
E	External fan supply monitor	31
F	features	7
G	general description	7
I	I2C-EEPROM	33
J	Jumper	19
L	LED descriptions	30
	LO-switch	17
M	Motherboard Z4P2997	17
O	operating point.....	30
	Operating point adjustment index A and higher	30
	Operating point adjustment index Z4P3032.....	30
P	PAL equations	19, 23
	PAL jumpers.....	12, 24
Q	QPSK modulator	26
	QPSK phase shifter	25
R	RF-SMA connectors	11
S	Schematics	45
	schematics	45
	SEL_OBS signal	12
T	Technical Data.....	37
	Temperature Controller.....	29
	temperature sensor	29

U		
	UXNMR.....	33
V		
	variofan.....	29
W		
	wobbling	15
Y		
	Y-cable	12, 41
	Y-cable wiring diagrams	41, 55, 61, 67, 81

Features

1.1

- Wideband transmit-receive unit
- SE451 high frequency housing with 5 slots
- 3 broadband transmitter RF-channels
- 3 channel observe capability
- 3 channel 4 Phase Modulator (optional)

General Description

1.2

The 3 channel SE451 consists of three transmitter boards (TF1, TF2 and TF3, or TFX, TFH and TFY), a local oscillator unit (generating signals for frequency synthesis in the transmitter boards) and a receiver. These five boards are plugged onto a motherboard which provides power supply lines and distributes logic signals from the front panel connectors via a PAL to the individual units. On the motherboard a SP3T-RF-switch selects the local oscillator signal of the observed channel.

Block Diagram

1.3

The following block diagram gives overall information about the 3 channel SE451 unit and its frequency generation principle.

SE451 3-CHANNEL

Figure 1: SE451-3CH frequency generation and block diagram

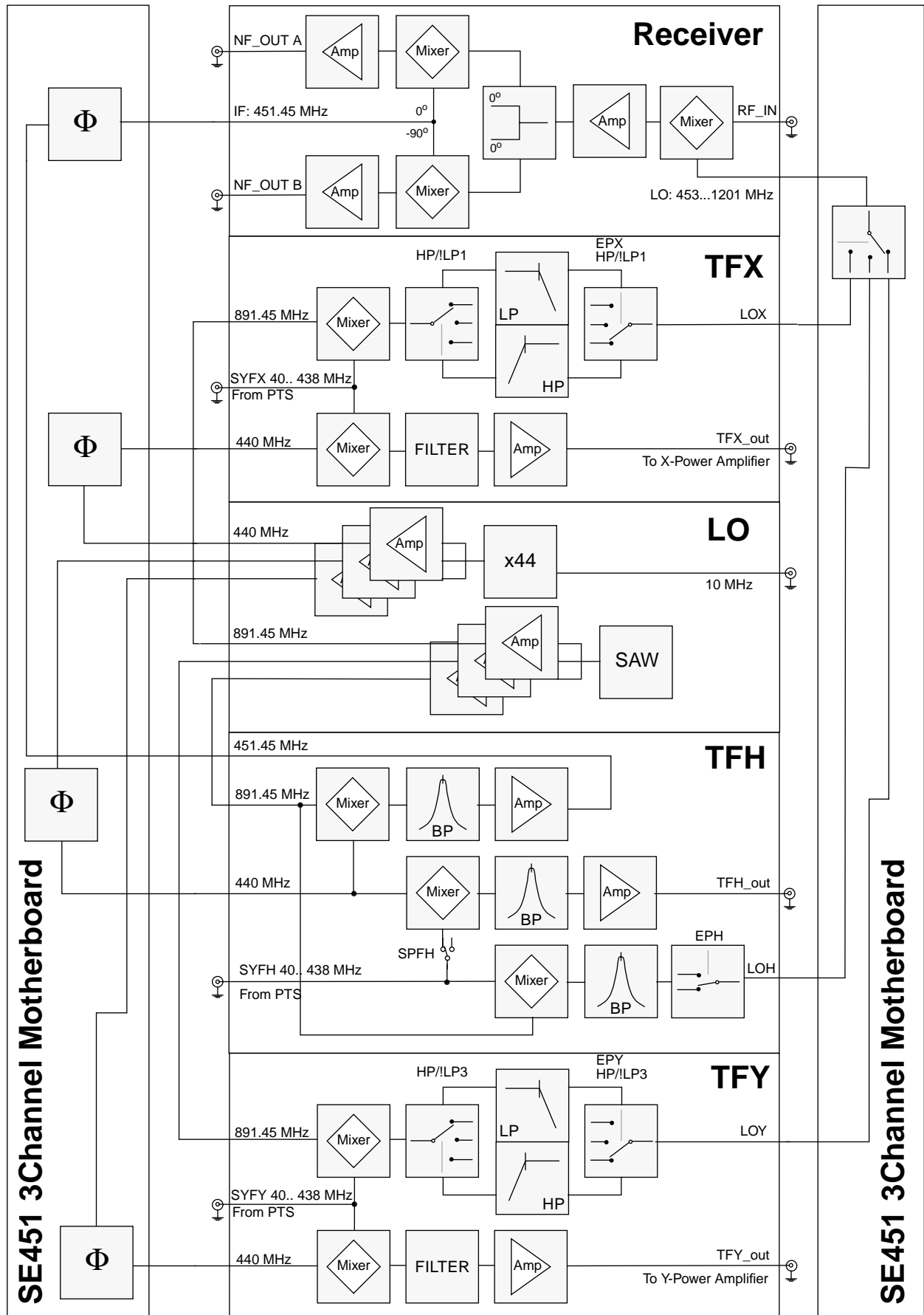
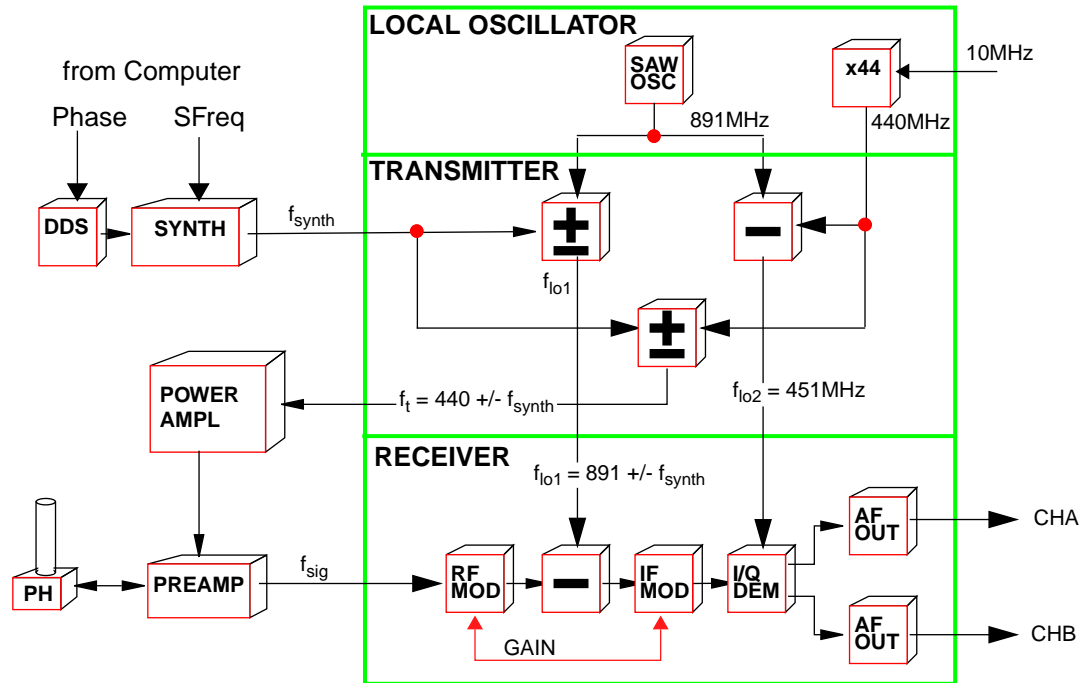

Figure 2: Function diagram SE451



Receiver Gain

1.4

The most used parameter which is set by the operator is the receiver gain. The following description gives information about the receiver gain.

Receiver Gain calculation

1.4.1

The receiver gain (voltage gain) can be set within a range of 12dB to 102dB. The operator is used to set a linear gain via the UXNMR. The following equation describes the relationship of the 'UXNMR-Gain' and the logarithmic voltage gain (between input RF_IN and the audio outputs CHA and CHB) of the SE451 receiver.

$$Gain_{UXNMR} = 10^{\left(\frac{Gain_{RFT} - 12}{20}\right)}$$

$$Gain_{RFT}[dB] = 20\log(Gain_{UXNMR}) + 12dB$$

In the SE451 receiver the gain can be set in steps of 6dB. The following table lists the different gains and the according control signals

Tabelle 1. Gain Table for 6dB Steps SE451-3CH

RG	RG UXNMR	RG [dB]	DRG0 (RG6)	DRG1 (IF0)	DRG2 (AGC_A)	DRG3 (AGC_B)	DRG4 (RF_A)	DRG5 (RF_B)
1	1	12	0	1	0	0	0	0
2	2	18	1	1	0	0	0	0
4	4	24	0	1	0	0	1	0
8	8	30	1	1	0	0	1	0
16	16	36	0	1	0	0	0	1
32	32	42	1	1	0	0	0	1
64	64	48	0	1	0	0	1	1
128	128	54	1	1	0	0	1	1
256	256	60	0	0	0	0	1	1
512	512	66	1	0	0	0	1	1
1k	1024	72	0	0	1	0	1	1
2k	2048	78	1	0	1	0	1	1
4k	4096	84	0	0	0	1	1	1
8k	8192	90	1	0	0	1	1	1
16k	16384	96	0	0	1	1	1	1
32k	32768	102	1	0	1	1	1	1

General

2.1

This chapter describes the Burndy connectors, the RF-SMA and RF-BNC connectors and the Sub-D connector on the front panel of the SE451-3CH.

Burndy1 connector (SE451 Control)

2.2

Burndy1 is used as general purpose connector (SE451 Control), where all control-, pulse- and power supply- signal are wired. Pins B, C, F, H, L, M, R, S, V, W, Z, AA, DD, JJ, NN are coaxial RF-wires with female connectors whereas pins A, D, E, J, K, N, P, T, U, X, Y, BB, CC, FF, HH, LL and MM are DC-wires with male connectors.

Figure 3: Burndy1: SE451-3CH control connector



Tabelle 2. Burndy1 signal description

Signal name	signal description
DRG0 - DRG6 (RG6, IF0, AGC_A, AGC_B, RF_A, RF_B, RES(TP9))	Signals controlling the receiver gain, in brackets signal names of earlier SE451 2channel units.
RGPa, RGPb	Receiver gating pulse A (RGPA) and B (RGPB)
!TGPCH1a, !TGPCH2a, !TGPCH3a	Transmitter gating pulse signals of channel 1, 2 and 3, low activ
HP!/LP1, HP!/LP2, HP!/LP3	Highpass/Lowpass control lines for transmitter channels 1, 2 and 3.
!OBS_CH1_(X), !OBS_CH2_(H), !OBS_CH3_(Y)	These signals determine the observe channel and select the appropriate local oscillator reference signal.
10MHz_4, 10MHz_7	10 MHz OUTPUTs from the LO-Board.
SEL_OBS	Select observe signal (also called reverse signal), used only for compatibility to earlier SE451 2 channel units when using the Y-cable as interface and setting the PAL-jumpers on the motherboard accordingly. SEL_OBS is connected to OBSERVE_H~ on the SE451 3channel motherboard. SEL_OBS high selects the X-channel, SEL_OBS low the H-channel as observe-channel.

Burndy2 wires all control signals for the 4Phase-Modulator which is located on the SE451-3Channel motherboard. All connected pins are RF-coaxial wires with male connectors.

Figure 4: Burndy2: 4 Phase Modulator Control Connector

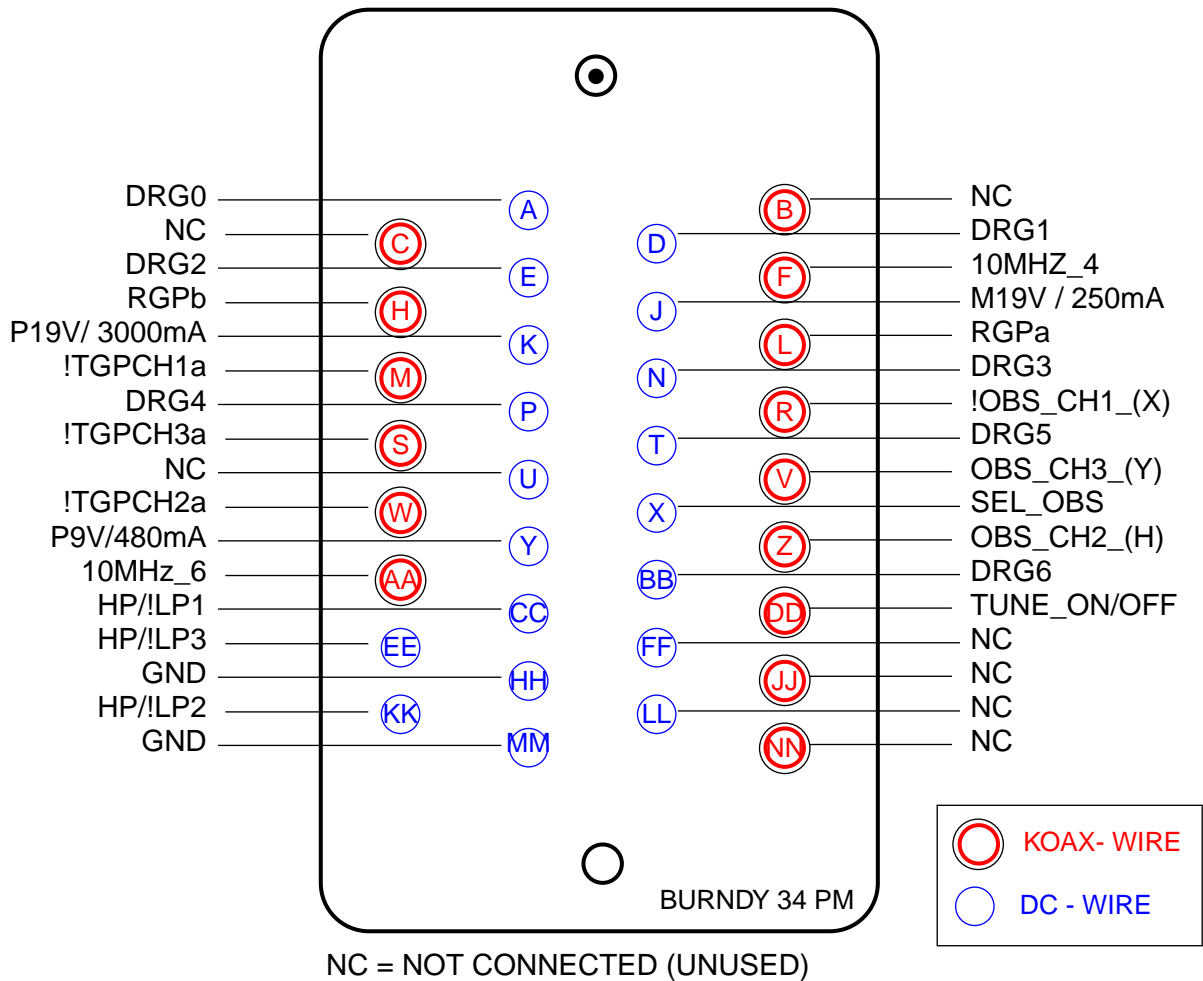
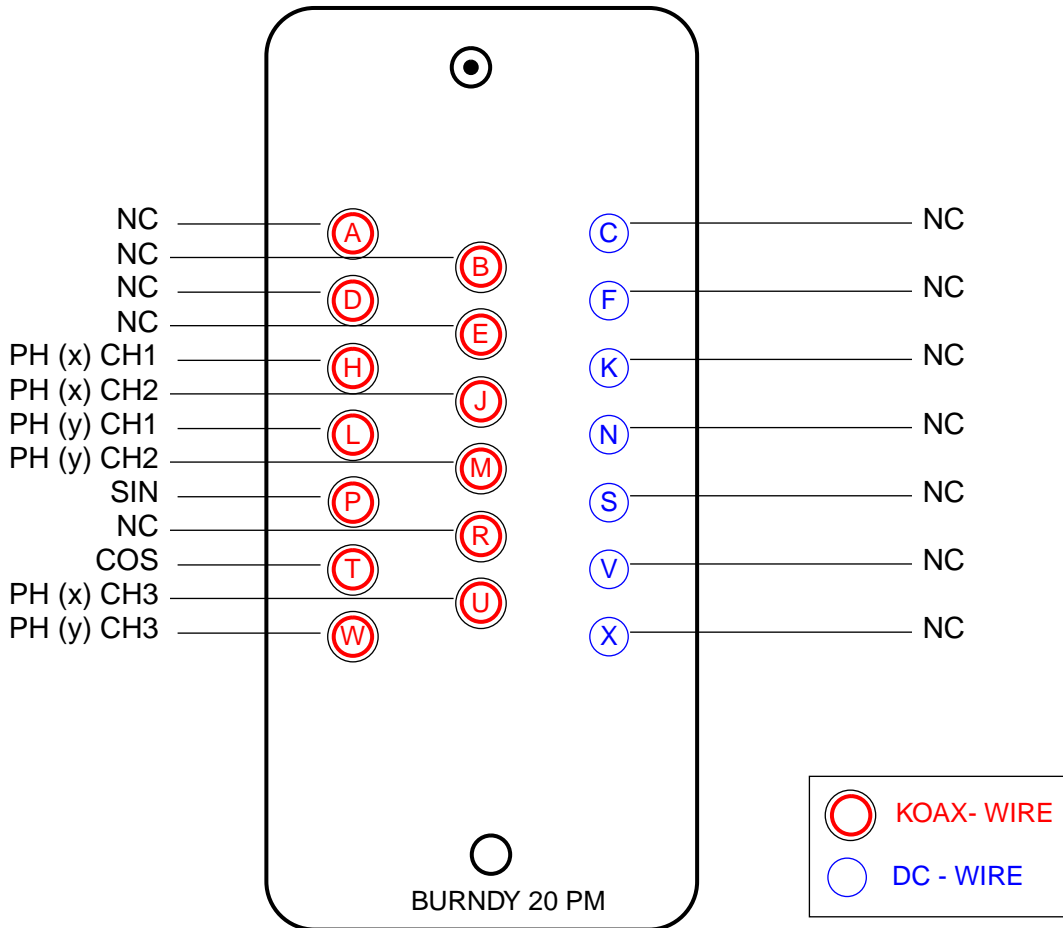

NC = NOT CONNECTED (UNUSED)

25 Sub-D Connector (male, RXC-Control)

The following diagram shows the pin assignment of the 25 Sub-D RXC-Control connector on the SE451-3CH front panel. The pin numbers at the outside correspond to the Sub-D numbering scheme, the numbers near the pins are according to the pin assignment of connector J75 (surface mounted 26 pin connector) on the SE451-3CH motherboard. Note that pin 26 of connector J75 is not wired to the RXC-Control Sub-D front panel connector. The signals for gain-setting (DRG0 to DRG6) and the filter selection signals (HP/!LPx) are wired on Burndy1 connector as well. The according pin assignment is also given in the table below.

Figure 5: RXC Control 25 Sub-D Connector Pin Assignment

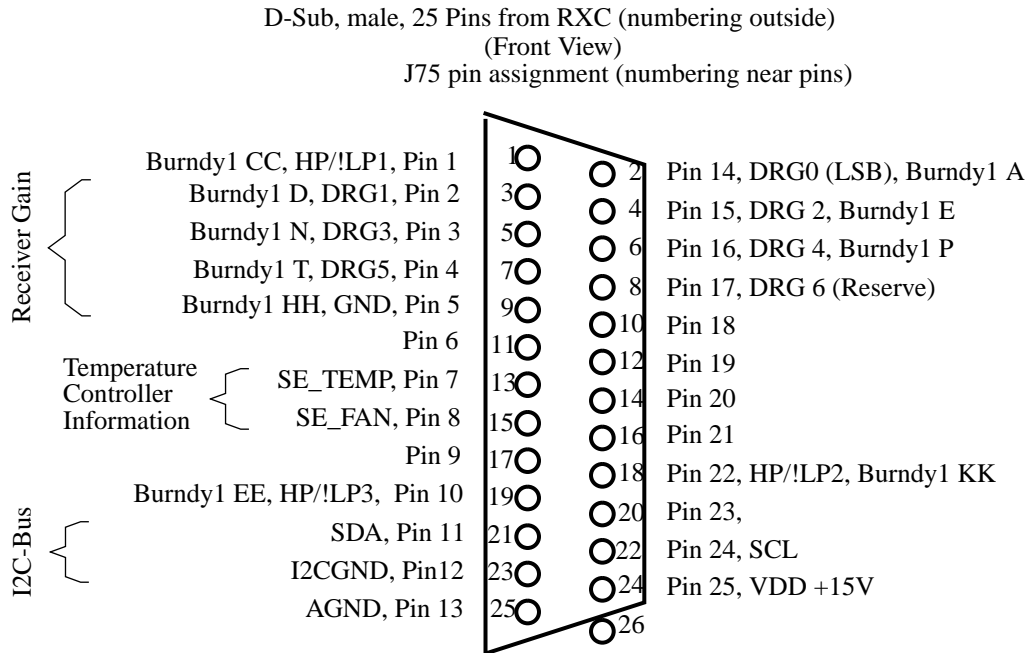

SMA and BNC connectors

2.5

On the front pannel the following signals have SMA or BNC connectors:

Table 3. SMA connectors on the front pannel of the SE451-3CH

signal name	signal description
Synth_F1	(PTS-) synthesizer input for channel X (channel 1)
F1_out	X- (1-) transmitter output (to power amplifier)
Synth_F2	(PTS-) synthesizer input for channel H (channel 2)
F2_out	H- (2-) transmitter output (to power amplifier)
Synth_F3	(PTS-) synthesizer input for channel Y (channel 3)
F3_out	Y- (3-) transmitter output (to power amplifier)
10MHz_In	10MHz Input
CHA	NF output, channel A
CHB	NF output, channel B
CHA_BB	Broadband, 50Ohm NF-Output, Channel A
CHB_BB	Boradband, 50Ohm NF-Output, Channel B

Tabelle 4. BNC connectors on the front pannel of the SE451-3CH

signal name	signal description
RF_IN	RF Input from preamplifier
Tune_Out	Tuning output for wobbling

Alternativ signal names**2.6**

For compatibility reasons to older SE451-versions and for test purposes on the motherboard of the SE451-3CH alternativ signal names (corresponding to older units) have been used on the screen printing. These names are given in the following table:

Tabelle 5. Alternativ signal names used on the screen printing of the SE451-3CH motherboard

signal name	2nd name	Burndy1 Pin	25 Sub-D Pin	Module Connector Pin	J75 Pin Assignment
DRG0	RG6	A	14	J1 2A	2
DRG1	IF0	D	2	J1 3C	3
DRG2	AGC_A	E	15	J1 4D	4
DRG3	AGC_B	N	3	J1 5E	5
DRG4	RF_A	P	16	J1 6F	6
DRG5	RF_B	T	4	J1 7H	7
DRG6	RES (TP9)	BB	17	-	8
HP!/LP1	FILTER_X	CC	1	J2 2B	1
HP!/LP2	FILTER_H	KK	22	J4 2B	18
HP!/LP3	FILTER_Y	EE	10	J5 2B	19
SEL_OBS	REVERSE	X	-	-	-

The built in fan with and its temperature controller board are supplied by an external source. The ext. supply connector is located at the back of the SE451 housing.

The pin assignment is as follows:

Figure 6: ext. supply connector pin assignment

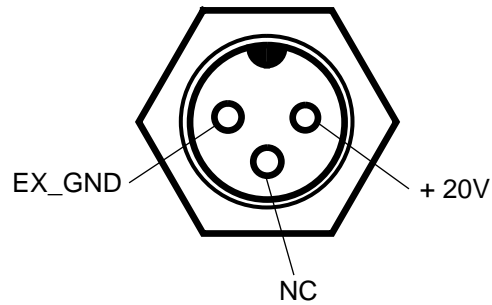

General

3.1

On the motherboard all the signals of the different modules and the front panel connectors are routed. A PAL provides the possibility to adjust gating pulses to different console wirings via jumpers (see the chapter about the PAL in this manual). As well on the motherboard a SP3T RF-switch routes the three local oscillator signals which determine the observed channel. A block diagram of this small RF circuit can be found in the next paragraph. For units with 4Phase Modulator the phase shifters are implemented on the motherboard as well

Block diagram LO-switch

3.2

To provide good isolation between the three local oscillator signals and the output (as well as good cross isolation between the three LO-signals themselves) and for a good matching attenuators have been placed at the inputs and the output of the SP3T switch. A frequency correction network provides a flat insertion loss/gain characteristic over the range of 400MHz to 1200MHz.

Figure 7: Block diagram of the LO-Switch on the SE451-3CH motherboard Z4P2997

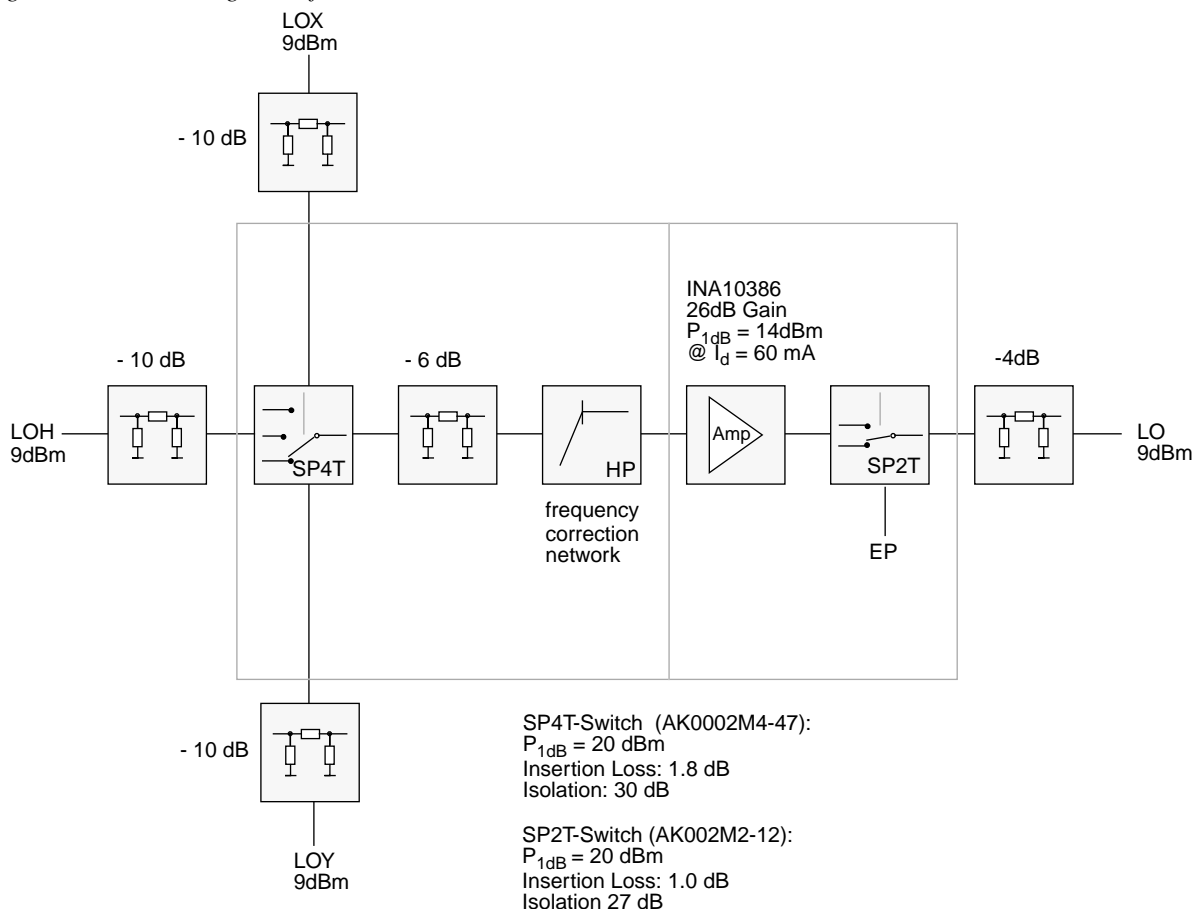

General

4.1

This chapter describes the equations used in the PAL (IC7, EP910PLCC) on the SE451-3CH motherboard. The following mnemotechnics were used:

NOBL: New Observe Logic

NEPL: New EP (Empfangspuls=Receiver Pulse) Logic

INVEP: Inverted EP

INVTGP: Inverted TGP (Transmitter Gating Pulse)

Jumpers

4.2

The 3-Channel SE451 can be configured for high active control signals (old mode) or low active control signals (new mode). There are 4 solder-type jumpers (JU1 ... JU4) located just below the PAL-socket on the motherboard.

Figure 8: Location of the jumpers JU1 ... JU4

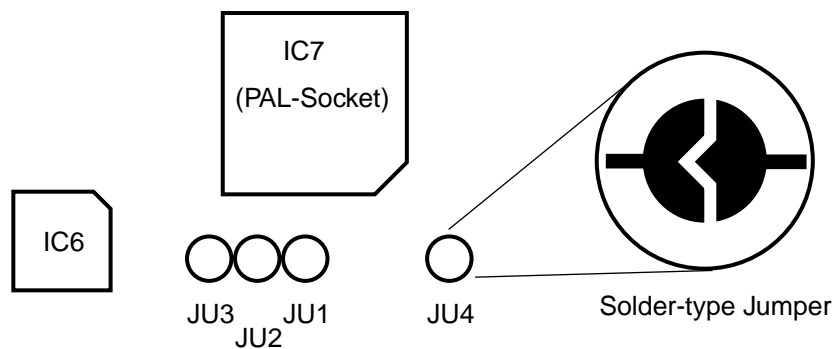

All 3-CH SE451 are factory configured for low active control signals (unless specific ordered).

Tabelle 6. Jumper settings (factory configuration):

Jumper	Setting	Description
JU1	open	Low active transmitter gating pulses (!TGPCH1a, !TGPCH2a and !TGPCH3a)
JU2	open	Low active receiver gating pulses (RGPa and RGPb)
JU3	open	Transmitter and receiver switched by one pulse only (RGPa)
JU4	open	Observe channel selected by three separat signals !OBS_CH1_(X), !OBS_CH2_(H) and !OBS_CH3_(Y)

Jumper settings for other configurations

If the SE451 3-CH unit is used as a replacement for an older 2-CH unit the jumpers have to be set as follows:

Tabelle 7. Jumper settings for replaced 2-CH units:

Jumper	Setting	Description
JU1	closed	High active transmitter gating pulses (!TGPCH1a, !TGPCH2a and !TGPCH3a)
JU2	closed	High active receiver gating pulses (RGPa and RGPb)
JU3	closed	Transmitter and receiver switched by two different pulses: RGPa => EP, RGPb => EPX, EPH
JU4	closed	Observe channel selected by one signal only: SEL_OBS high = H, SEL_OBS low = X

Modification for OBS-SEL logic:

The SEL_OBS signal used in this configuration is wired in the y-cable attachment to the old console wiring, but not in the SE451 3-CH chassis. An additional DC-contact must be inserted as pin X in the connector Burndy 1 and wired to the !OBS_CH2_(H) signal on the motherboard (special pad available).

This modification is normally done prior to delivery at the factory. A field modification is difficult because of limited access and therefore not recommended.

Tabelle 8. Description of the jumpers on the SE-451-3CH motherboard:

Jumper (Signal)	Function	Setting	Description
JU1 (INVTGP)	Selects between high or low active transmitter gating pulses !TGPCH1a, !TGPCH2a and !TGPCH3a	open closed	Low active transmitter gating pulses. High active transmitter gating pulses.
JU2 (INVEP)	Selects between high or low active receiver gating pulses RGPa and RGPb.	open closed	Low active receiver gating pulses. High active receiver gating pulses.
JU3 (NEPL)	Selects between one or two receiver gating pulse RGPa only or RGPa and RGPb.	open closed	Transmitter and receiver EP's switched by one pulse only (RGPa). Receiver (EP) switched by RGPa, transmitters (EPX, EPH and EPY) switched by RGPb.
JU4 (NOBL)	Selects between one or three observe select signals OBS_SEL or !OBS_CH1_(X), !OBS_CH2_(H) and !OBS_CH3_(Y).	open closed	Three observe select signals !OBS_CH1_(X), !OBS_CH2_(H) and !OBS_CH3_(Y), one for each channel. One observe select signal OBS_SEL (OBS_SEL high = H-channel, low = X-channel).

Tabelle 9. Input signals of the PAL, IC7

Input signal	Pin-Nr. PLCC
RGP _a	Pin 19
RGP _b	Pin 20
!TGPCH _{1a}	Pin 21
!TGPCH _{2a}	Pin 25
!TGPCH _{3a}	Pin 26
!OBS_CH ₁ (X)	Pin 27
!OBS_CH ₂ (H)	Pin 3
!OBS_CH ₃ (Y)	Pin 4
NOBL (Jumper JU4)	Pin 5
NEPL (Jumper JU3)	Pin 41
INVEP (Jumper JU2)	Pin 42
INVTGP (Jumper JU1)	Pin 43

Tabelle 10. Output signals of the PAL, IC7

Output signal	Pin-Nr. PLCC
EP	Pin 32
EPX	Pin 35
EPH	Pin 34
EPY	Pin 33
SPFX	Pin 31
SPFH	Pin 30
SPFY	Pin 29
LO1	Pin 6
LO2	Pin 7
LO3	Pin 8
LO_ON	Pin 9

In the PAL equations the following abbreviations were used

&: logical AND-relation

#: logical OR relation

\$: logical EXOR-relation

!: inversion

Tabelle 11. PAL equations of IC7, EP910PLCC

Signal	Equation
EPinta	RGPa \$ INVEP
EPintb	RGPb \$ INVEP
obsX	!(OBS_CH1_(X))
obsH	!(OBS_CH2_(H))
obsY	!(OBS_CH3_(Y))
EP	EPinta (Standard pulse for the receiver)
SPFX	!TGPCH1a \$ INVTGP
SPFH	!TGPCH2a \$ INVTGP
SPFY	!TGPCH3a \$ INVTGP
EPX	obsX & !obsH & !obsY & EPinta & NEPL & NOBL #(obsX & !obsH & !obsY & EPintb & !NEPL & NOBL) #(!obsH & EPinta & NEPL & !NOBL) #(!obsH & EPintb & !NEPL & !NOBL)
EPH	!obsX & obsH & !obsY & EPinta & NEPL & NOBL #(!obsX & obsH & !obsY & EPintb & !NEPL & NOBL) #(obsH & EPinta & NEPL & !NOBL) #(obsH & EPintb & !NEPL & !NOBL)
EPY	!obsX & !obsH & obsY & EPinta & NEPL & NOBL #(!obsX & !obsH & obsY & EPintb & !NEPL & NOBL)
!LO1	EPX (LO-SP4T-switch is LOW-active)
!LO2	EPH (LO-SP4T-switch is LOW-active)
!LO3	EPY (LO-SP4T-switch is LOW-active)
LO_ON	EPX # EPH # EPY (LO-SP2T-switch is HIGH-active)

In the following figure you find the pin connections of the pal on the motherboard of the SE451-3CH. The signal names correspond to the names in the above tables.

Figure 9: Pin Connections of the PAL on the motherboard of the SE451-3CH

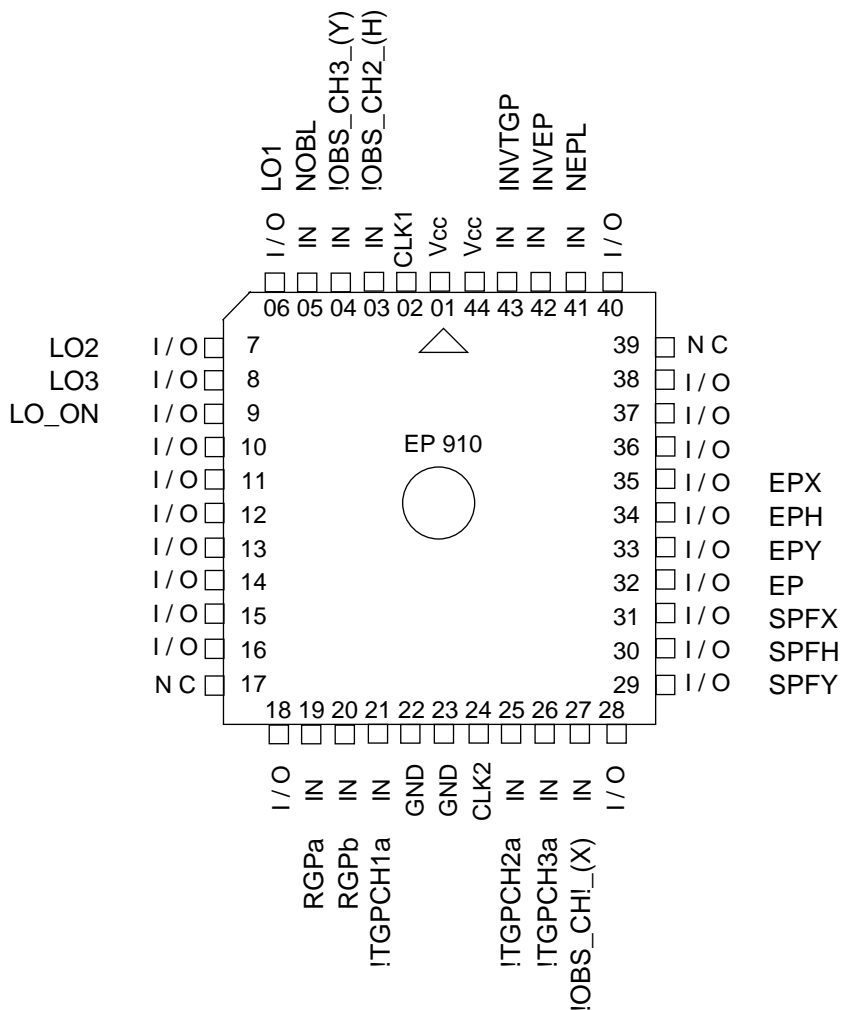

The SE451-3CH can be equipped with a 4Phase Modulator located on the motherboard. The 4Phase Modulator is controlled via Burndy2 connector by the 4Phase Modulator control board in the acquisition rack (AQR). This system provides fast phase switching of the three transmitter outputs and the receiver phase.

Block Diagram of 4Phase Modulator RF Board (RF part only)

The embedding of the 4Phase Modulator in the SE451-3CH environment can be seen in the overall . The 4Phase Modulator controls the phase of the 440 MHz local oscillator signals for the transmitters and the 451.45 MHz signal. This is done by QPSK phase shifters (FPQ-475 by MiniCircuits). In the chosen operation mode the QPSK modulators have an insertion loss of about 12 dB which is compensated by an amplifier. The overall gain of any of the four phase shift paths is 0 dB. The 3dB loss due to the power splitter in the TFH signal path is compensated by an additional amplifier/attenuator combination.

Figure 10: Block Diagram of the 4Phase Modulator RF Board

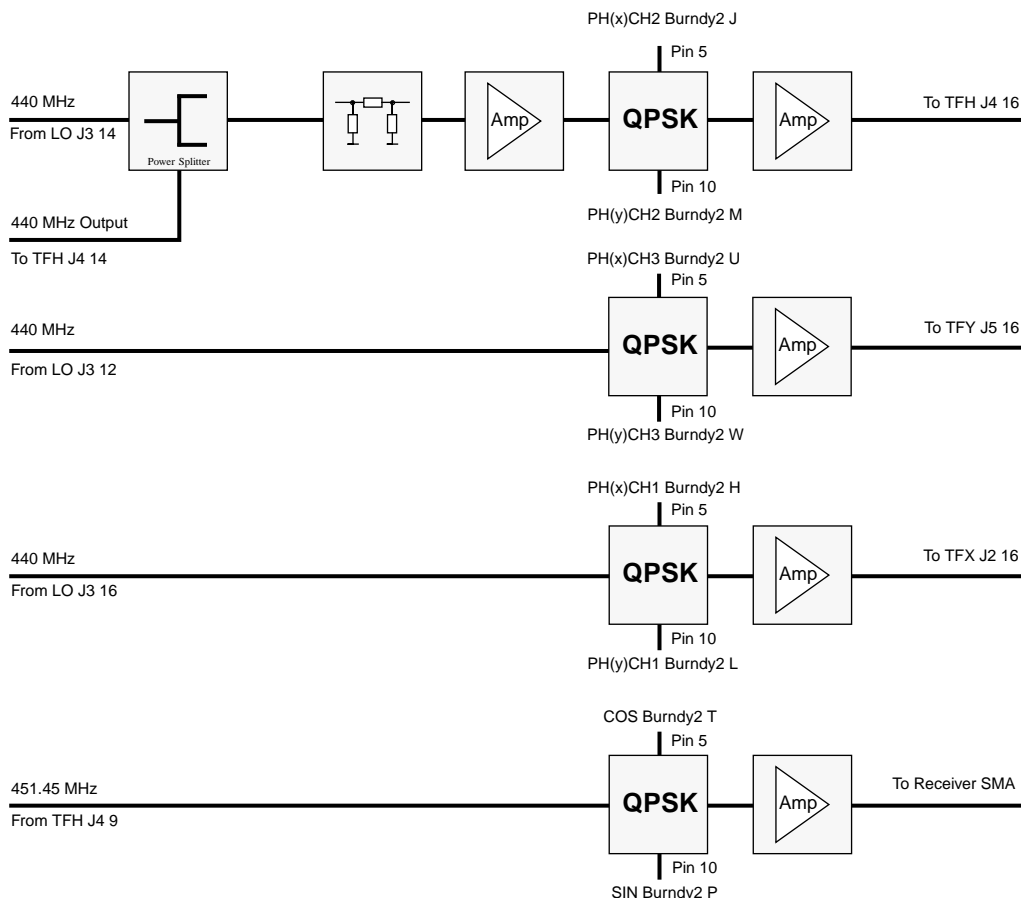

The QPSK-Blocks can be represented by the following block diagram:

Figure 11: Block Diagram of QPSK-Modulator

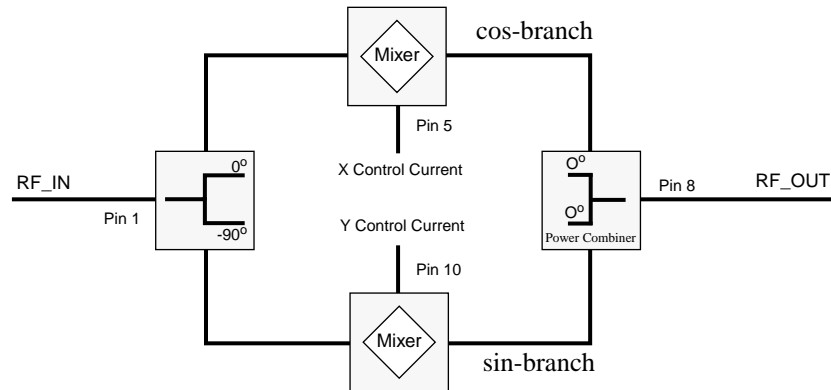

The mixers in the cosine and sine branches in the block diagram of the QPSK-modulator are diode ring mixers and operate as switches for the RF signal. By applying positive current (normally in the order of 20 mA) to the control port of the mixer, the RF signal is transferred without phase shift. With a negative current, the RF signal is inverted. No control current results in isolation of the according branch. The four possible control currents result in four different phase states as shown in the following figure:

Figure 12: Phase states in normal operation mode of a QPSK-modulator

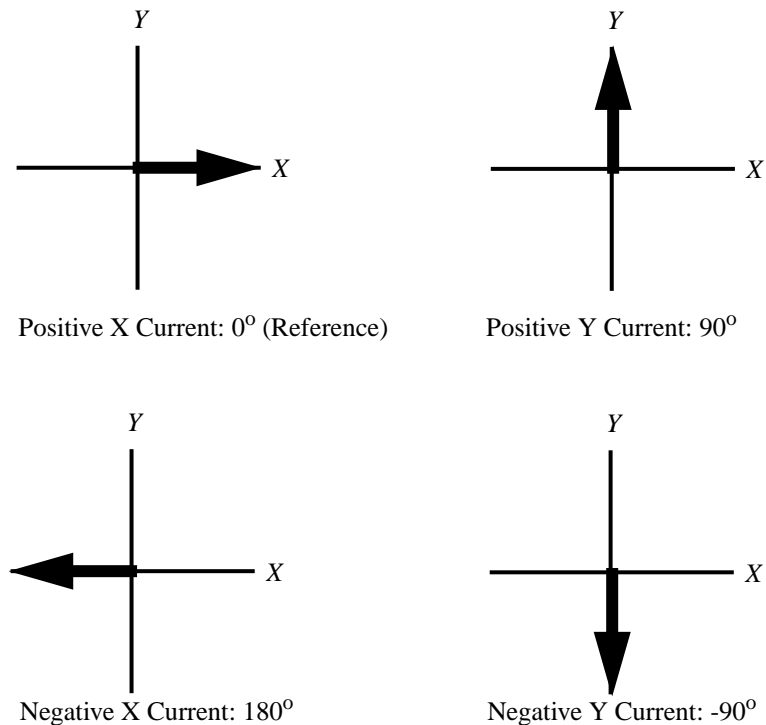

The definition of the 90° and -90° phase shift is of course somewhat arbitrary, as the sign of the phase shift of the 90° power splitter at the input of the QPSK-block is not known and was chosen to be -90° in the above example.

Function description of the 4Phase Modulator

5.4

As an extension of the normal operation of a QPSK-modulator the mixers can be used as electronic attenuators, the attenuation being set by the diode control current at the LO-port of the mixer. In addition the two branches (sine and cosine) can be selected at the same time. If the RF signal is again represented by a vector in the XY-plane the vector can now reach any point in the coordinate system. With some trigonometry the principle is easily understood:

Suppose the RF input signal is

$$A \cdot \cos(\omega t)$$

A_X being any amplitude of no importance. After the mixer the signal in the cosine branch is

$$A_X \cdot \cos(\omega t)$$

A_Y being controlled by the X control current. Again after the mixer, the signal in the sine branch is

$$A_Y \cdot \sin(\omega t)$$

A_Y is controlled by the Y control current. After the power combiner at the output, the RF signal is

$$A_X \cdot \cos(\omega t) + A_Y \cdot \sin(\omega t)$$

which is equal to

$$A \cdot \cos(\omega t + \varphi)$$

with

$$A = \sqrt{A_X^2 + A_Y^2} \quad \varphi = \operatorname{atan}\left(\frac{-A_Y}{A_X}\right)$$

The next figure shows again the XY-plane and the conditions on A_Y and A_X for the RF signal vector to be in one of the four quadrants.

4Phase Modulator

Figure 13: Control currents for 4 quadrant phase shift

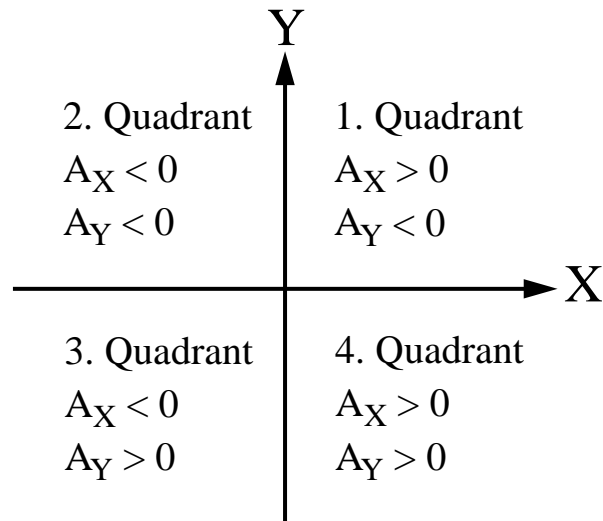

General

6.1

The SE451-3CH is equipped with a temperature controller. This device regulates the temperature to a constant operating point to ensure maximum stability. Even if the regulator is switched off the system is very stable due to the ingenious air guide and the long time constant for temperature changes (in the order of 15 minutes).

For stable operation the spectrometer should be in an air-conditioned room. The temperature controller is able to compensate the remaining temperature changes of an air-conditioning system (about +/-4 degrees). The regulator does not eliminate the need for air-conditioning as it has not been designed to compensate large temperature differences (e.g. 10 degrees or more).

There are basically two different versions of the temp. contrl. board installed in the SE451-3CH. They are referred to in this chapter as print index Z4P3032 and as index Z4P3032A or higher (Z4P3032A and B). The main difference is the operating point adjustment procedure. The easiest way to find out which controller version is installed in your unit is by counting the LED's at the front panel. Index Z4P3032 has two (one green and one red), index Z4P3032A or higher has three (one green and two red).

Function description

6.2

A temperature sensor (AD592) measures the temperature in the QD-module of the receiver of the SE451-3CH unit. This sensor signal is fed into a P-regulator which controls the input voltage of the variofan cooling the unit (regulation of the air flow by varying the speed of rotation (revolutions per minute) of the fan).

Operation

6.3

The temperature controller tries to keep the temperature inside the unit constant. However it can only do so for ambient temperatures within a certain range around a preset regulator operating point. The higher the ambient temperature the smaller the temperature range which the controller is able to compensate. At an ambient temperature of 20° Celsius (293K) this range is +/-5 degrees around the operating point. At 30° Celsius (303K) this range reduces to +/-3 degrees.

If the ambient temperature leaves the range which the controller can compensate, an error is indicated by the error LED on the front panel. The controller operating point must then be adjusted to the new ambient temperature. The following paragraph describes how to adjust the operating point of the regulator.

To adjust the operating point you must first switch the controller off with the front panel switch (position REGULATOR OFF). This mode disables the regulator and connects the fan to a constant voltage (9V). The system must then be stabilized at the new ambient temperature for at least one hour.

After this time the regulator operating point can be adjusted on the front panel potentiometer („Operating Point Adjust“). The aim of the adjustment is to reach a regulator output voltage of 9V (the same as the constant fan voltage when the regulator is off). The regulator output voltage can be measured with a voltmeter at pin 8 of the 25 Sub-D connector RXC on the front panel of the SE451-3CH. If you measure this voltage you must turn the adjustment-potentiometer until the voltmeter shows a reading of 1.8Volts.

If the adjustment has been performed the regulator can be switched on (REGULATOR ON) with the front panel switch.

The adjustment of the controller operating point has been improved for boards with index A and higher (Z4P3032A or B). An additional LED has been implemented (named „Not Adjusted“ on the front panel) to indicate the proper setting of the regulator operating point. The procedure of the regulator adjustment is as follows:

Switch the controller off with the front panel switch (position REGULATOR OFF). This mode disables the regulator and connects the fan to a constant voltage (9V). The system must then be stabilized at the new ambient temperature for at least two hours. After this time the regulator operating point can be adjusted on the front panel potentiometer („Operating Point Adjust“). The red LED („Not Adjusted“) is on as long as the regulator operating point is not adjusted. The LED turns off if the regulator is adjusted. Turn the potentiometer until the „Not Adjusted“-LED does no longer shine. Be aware that the „off window“ of the LED is quite small and therefore easy to miss if the adjustment is done too fast. You can then switch on the regulator with the front panel switch (REGULATOR ON).

The green LED (+19V) indicates that the +19V supply of the fan is OK. In both modes (REGULATOR ON and OFF) the green LED must be on. Otherwise the device is out of order and must be repaired.

If the regulator is on (REGULATOR ON switch position) the red LED (ERROR) indicates that the operating point should be adjusted. It does not mean however that NMR-experiments should not be performed. Just switch the regulator off (The ERROR LED does no longer shine) and go on with your measurements. The system is very stable even in the constant fan operating mode (REGULATOR OFF). For maximum stability adjust the operating point of the controller. To do this follow the procedure described above („Adjustment of the operating point“). During normal operation of the regulator the red LED should not shine.

If the regulator is off (REGULATOR OFF switch position) the red LED should never be on. If the LED shines in the „regulator off“-mode the device is out of order and must be repaired.

LED red: Not Adjusted (Z4P3032A and higher only)

For temperature controllers with index A and higher an additional red LED has been implemented to simplify the adjustment procedure of the regulator.

If the regulator is on (REGULATOR ON switch position) this red LED should never be on.

If the regulator is off (REGULATOR OFF switch position) this LED is on as long as the operating point of the controller is not properly set. Turn the „operating point adjust“ potentiometer until the LED turns off. If the operating point is adjusted the LED does not shine and the regulator can be switched on.

External fan supply

SE451-3CH units with temperature controller boards index Z4P3032A or higher are equipped with an external fan supply. This is either a modified PSD1 board in the AQR-Rack or an extra plug-in power pack. The ext. fan supply connector is located at the back of the SE451-3CH unit.

External fan supply monitor

The ext. supply voltage is monitored to ensure save operation of the SE451-3CH unit. If by any cause the ext. supply voltage fails, an alarm will sound. In this case check for proper connection and function of the ext. fan supply.

General

7.1

The SE451-3CH unit has a built in BBIS (Bruker Board Information System) chip. It is an I2C-EEPROM controlled via the RXC receiver controller board in the AQR rack. The BBIS circuit is galvanic isolated from the SE451 motherboard and supplied from the RXC board.

The BBIS information is structured into four blocks or pages in the following order:

1. Production page
2. Service page
3. Device block
4. Application block

Their contents is read by the UXNMR to configure the proper control signals for the SE451-3CH. They can also be read by the user with the RXC-tool.

Block / page description

7.2

Structure, datatypes and contents of the following blocks and pages are according to document ZDEN0001 BBIS-Manual. More detailed information is available from Spectrospin AG, Fällanden.

BBIS production page

7.2.1

This page contains all production data (serial numbers, production date and place etc.). It is factory configured and should therefore not be changed.

Tabelle 12. Example for a production page:

Type	Length	Data	Description
V	1	2	dataformat version for the production page
C	1	S	protocol devicename
S	5	SE19	device callname
S	16	Z003020	partnumber [example 300MHz unit]

Type	Length	Data	Description
T	16	0002	serialnumber
S	10	Z4P2997A	printnumber SE451 motherboard
U	1	16	hardware code SE451 motherboard
T	7	940506	produktion date [y m d]
C	1	Z	produktion location [Z = Zurich Fällanden]
U	1	1	produktion department
S	5	SLE	testengineer
I	1	3	test department
I	1	0	ECL (after delivery)
S	13	0	reserve (13 bytes, always 0)

BBIS service page
7.2.2

This page contains all service data (repair date and place etc.). It is factory configured and should therefore not be changed.

Tabelle 13. Example for a service page:

Type	Length	Data	Description
V	1	2	dataformat version for the service page
T	16	--	repair number
U	1	8	hardware code after repair
T	7	--	repair / modification date
T	5	--	service engineer
C	1	F	repair location
U	1	1	ECL after modification
S	15	0	reserve (15 bytes, always 0)

This block contains all device data (built-in modules and their configuration etc.). It is factory configured and should therefore not be changed.

Tabelle 14. Example for a device block:

Type	Length	Data	Description
V	1	0	dataformat version for the device block
U	1	1	motherboard type [1 = QUAD]
U	1	0	motherboard type reserve
U	1	250	1st transmitter type [TFX SL]
U	1	0	1st transmitter type reserve
U	1	57	2nd transmitter type [TFH SL 300MHz]
U	1	0	2nd transmitter type reserve
U	1	250	3rd transmitter type [TFX SL]
U	1	0	3rd transmitter type reserve
U	1	0	4th transmitter type [not placed]
U	1	0	4th transmitter type reserve
U	1	249	1st receiver type [SL]
U	1	0	1st receiver type reserve
U	1	0	2nd receiver type [not placed]
U	1	0	2nd receiver type reserve
U	1	0	3rd receiver type [not placed]
U	1	0	3rd receiver type reserve
U	1	0	4th receiver type [not placed]
U	1	0	4th receiver type reserve
U	1	0	LO reserve
U	1	0	LO reserve
S	42	0	reserve (42 bytes, always 0)

This block contains all application data. Users and service personnel can write in here any data they want, for example some special settings, adjustments etc. This block is not used by the UXNMR and therefore open to everyone.

Tabelle 15. Example for an application block:

Type	Length	Data	Description
V	1	2	dataformat version for the application block
S	16	--	reserve
S	16	--	reserve
S	16	--	reserve
S	14	--	reserve

General Specifications

8.1

Number of Channels with observe capability:	3
Frequency Range (FULLBAND):	5 750MHz
Frequency-Steps:	0.01Hz
TR Pulse (ON/OFF):	100nS
TR switching Time:	< 5uS
Phase Modulation:	0.1uS (0.05deg)(via DDS)
IF-Frequency:	451MHz (..MX,..SX) 22MHz (..RX)
Amplitude Stability:	RX: 0.15dB/K TX: -1dB/K
Phase Stability:	RX: 10°/K TX: 10°/K
Phase Modulation via WAVEFORM-Generator:	0.1uS (0.05deg)(via DDS)
Amplitude Modulation without WAVEFORM-Generator:	
Modulation:	60dB, 0.14dB Resolution
Attenuation:	90dB, 0.07dB Resolution
Gain Range (w/o Preamp):	-80 +10dBm
Noise Figure:	7 dB @ max. Gain ~50 dB @ min. Gain
Gain Steps:	3dB (..RX) 6 dB (..MX, ..SX)
Bandwith with BB Option:	400kHz (3dB) 2.5MHz (1dB)
Quad Image:	1% / 0.2% (QP, NS8)
O1-Spike:	1% / 0.2% (QP, NS8)
50Hz - Sidebands:	typ. 0.2%

Power Supply (including 4Phase Modulator)

8.2

Currents indicated are currents including 4Phase Modulator Option

+19V supply current:	2800 mA
-19V supply current:	300 mA
+9V supply current:	700 mA

Warm-up time constant

8.3

Warm-up time (time from system power-up to stable RF-operation)

Warm-up time

2 h

Pulse Propagation Delay (Motherboard only)

8.4

Pulse propagation delay of PAL (IC7) and Output Buffer (IC , 74AS757) on the SE451-3CH motherboard Z4P2997, according to data sheets (not measured):

Minimum Propagation Delay

33 ns

Maximum Propagation Delay

45 ns

Receiver Gain Table

8.5

Table 16. Gain Table for 6dB Steps SE451-3CH

RG	RG UXNMR	RG [dB]	DRG0 (RG6)	DRG1 (IF0)	DRG2 (AGC_A)	DRG3 (AGC_B)	DRG4 (RF_A)	DRG5 (RF_B)
1	1	12	0	1	0	0	0	0
2	2	18	1	1	0	0	0	0
4	4	24	0	1	0	0	1	0
8	8	30	1	1	0	0	1	0
16	16	36	0	1	0	0	0	1
32	32	42	1	1	0	0	0	1
64	64	48	0	1	0	0	1	1
128	128	54	1	1	0	0	1	1
256	256	60	0	0	0	0	1	1
512	512	66	1	0	0	0	1	1
1k	1024	72	0	0	1	0	1	1
2k	2048	78	1	0	1	0	1	1
4k	4096	84	0	0	0	1	1	1
8k	8192	90	1	0	0	1	1	1
16k	16384	96	0	0	1	1	1	1
32k	32768	102	1	0	1	1	1	1

Table 17: ECL Information for 3-Channel SE451

ECL	Additional Features or Changes	Print Index (Motherboard)	HW-Code	PLD Software
Prototype		Z4P2997A	8	
ECL 00	<ol style="list-style-type: none"> 1. BBIS Piggi-back print Z4P3031 2. Temp. Control Board index Z4P3032 or Z4P3032A 3. Ext. fan supply from AQR PSD1 board or from plug-in Power pack (Temp. Contr. Board index Z4P3032A only) 	Z4P2997B	16	SE30AA01-ZE
ECL 01	<ol style="list-style-type: none"> 1. BBIS on motherboard 2. Additional attenuator in each phase-shifter path 3. Temp. Control Board index Z4P3032B 4. Ext. fan supply from plug-in power pack 	Z4P2997C	32	SE30AA01-ZE

General

10.1

The Y-cable provides compatibility to earlier 2 channel SE451 units which have separate Burndy connectors with control and power supply lines for each individual SE451-module (TFX, TFH, LO and Receiver, RFT). In the SE451-3CH all power supply and control lines are contained in connector Burndy1 (See the chapter about Burndy1 connector (SE451 Control) on page 11). The Y-cable is the interface between these two connector systems.

Operation of SE451-3CH with Y-cable

10.2

In order for the SE451-3CH to behave like a 2 channel SE451 the Y-cable must be connected and the jumpers (solder-type) on the SE451-3CH motherboard must be set accordingly. For a description of the jumper settings see the chapter about PAL Equations on page 19, especially the paragraph about Jumpers on page 19. Basically all jumpers must be set when working in the 2 channel mode. For individual experiments or applications transmitter and/or receiver pulses can be inverted by appropriate jumper setting.

Note that the 3rd (Y-) channel of the SE451-3CH is not controlled via the Y-cable and performs no action in the 2 channel operating mode.

Wiring of the Y-cable

10.3

On the following pages you will find the wiring diagrams of the SE451-3CH Y-cable

SE 451 3 Channel
Burndy PM

R-FT
Burndy
RM

T-FX
Burndy
RM

LO
Burndy
RM

T-FH
Burndy
RM

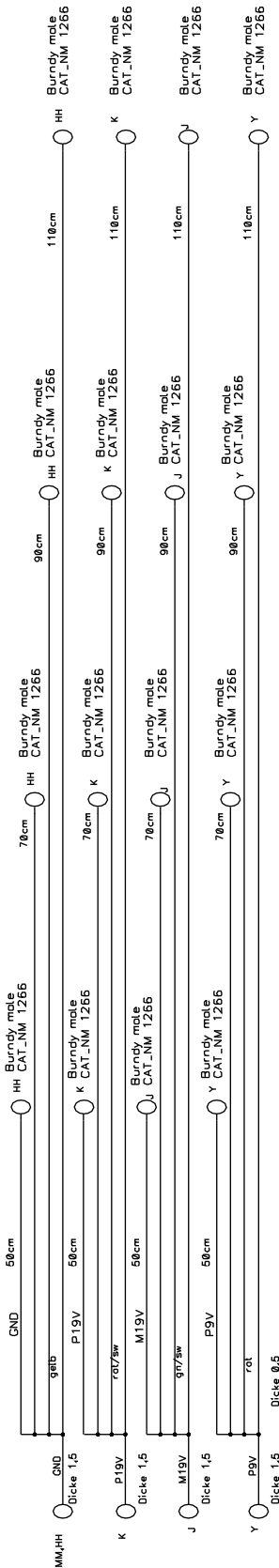
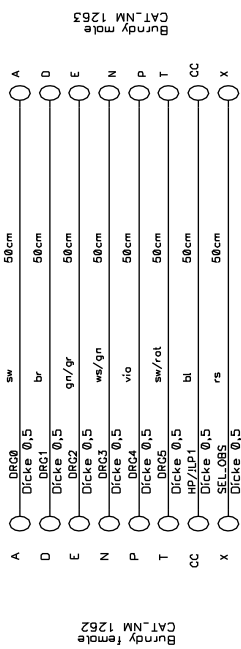

SE451-3CH

Y-Kabel

DC Wiring
Sheet 1 of 2

Print No:

DWG No:

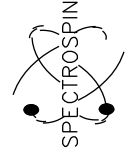

A3

Modification

Approv.

Drawn

Part-No.
for Drawing
only

SLE
24.05.94

Z12621

SE451-3CH
Burndy 34 PM

R-FT Burndy 34RM

T-FX Burndy 34RM

LO Burndy 34RM

T-FH Burndy 34RM

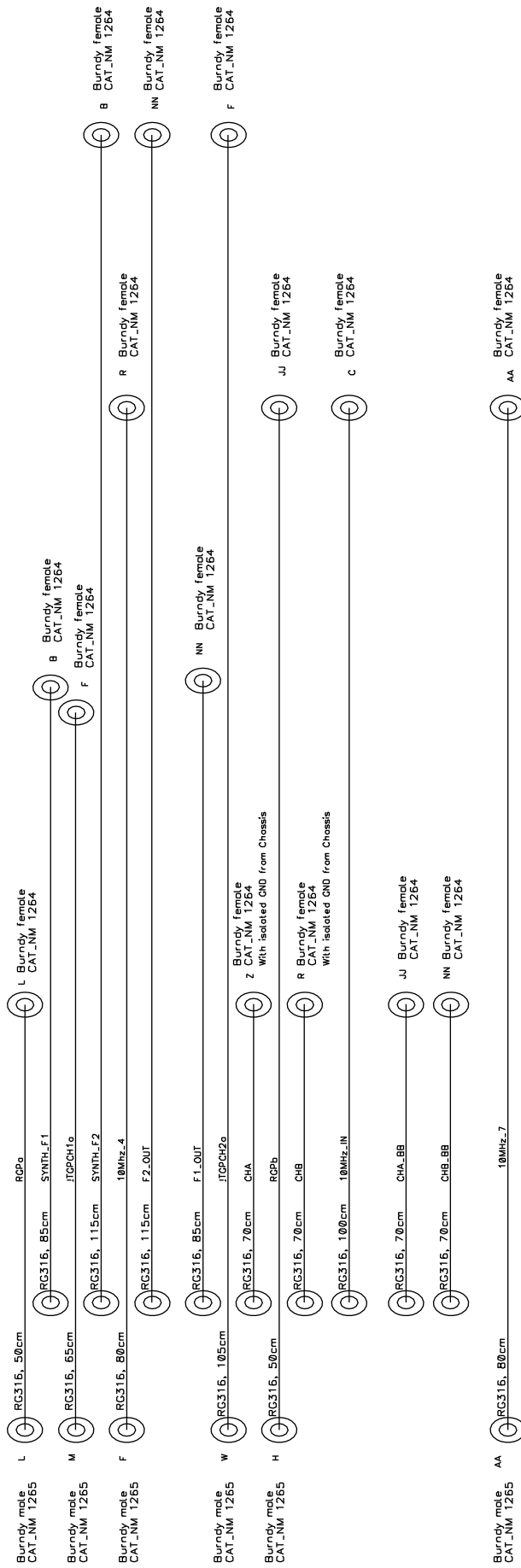

SE451-3CH

Y-Kabel

HF Wiring

Sheet 2 of 2

Print No:

DWG No:

Part-No. for Drawing only	Drawn	Approv.	Modification	A3
Z 12621	SLE			
	24.05.94			

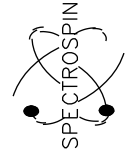

On the following pages you will find the schematics of the SE451-3CH motherboard Z4P2997C..

Motherboard Index B:

The SE451-3CH motherboard index B is almost identical to the index C described in this chapter. The only differences are the location of the BBIS circuit and the connection to the Temp. Contr. board.

The BBIS circuit is new on the motherboard itself, whereas on index B it was on a piggy-back print. For further information please refer to the BBIS schematic chapter.

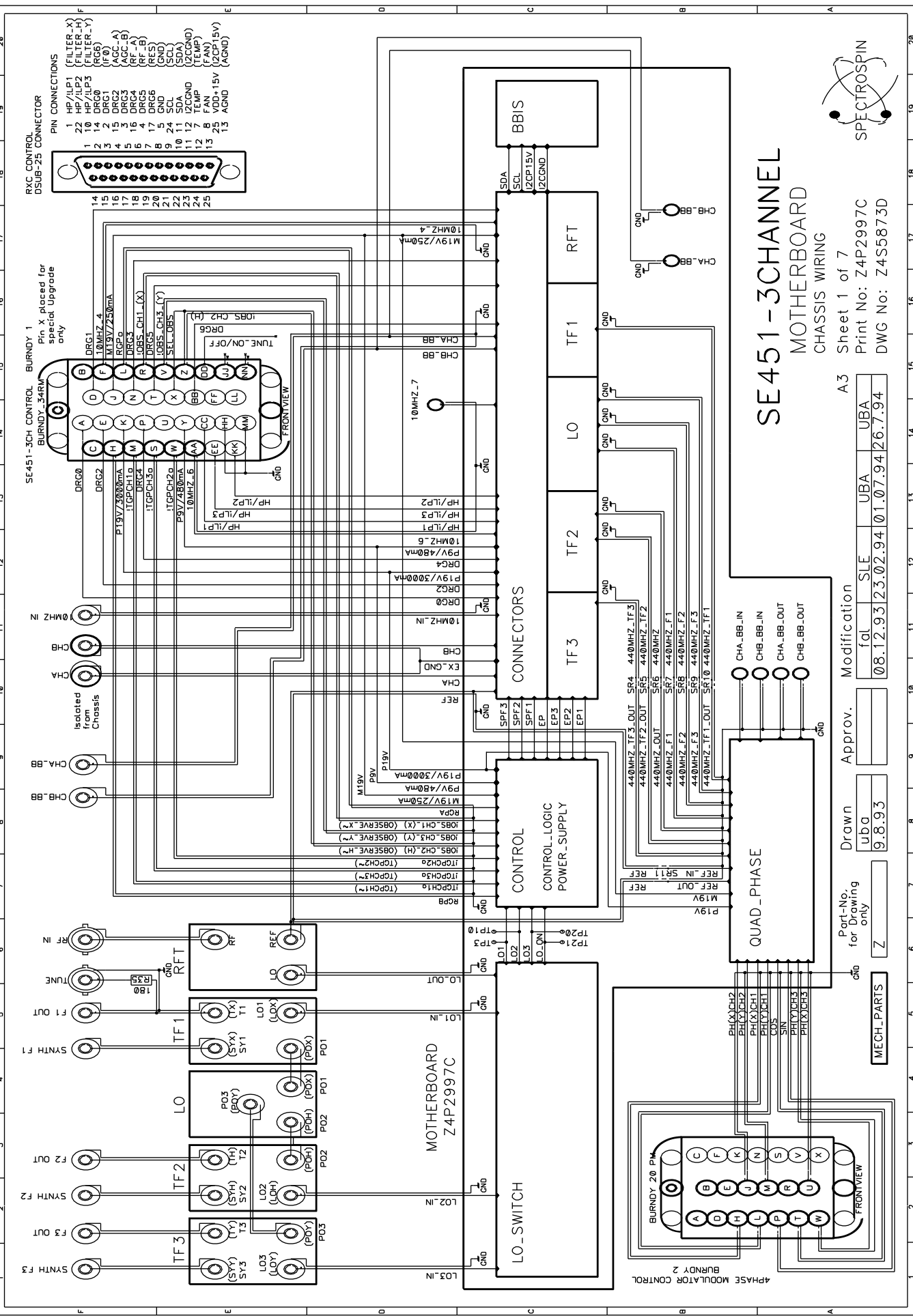

SE451-3CHANNEL

MOTHERBOARD

CHASSIS WIRING

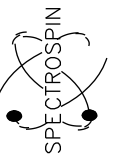

Sheet 1 of 7
 Print No: Z4P2997C
 DWG No: Z4S5873D

A3

Modification	UBA	UBA	UBA
Drawn	ubc	ubc	ubc
Approved			
Part-No. for Drawing only	Z		

08.12.93	23:02.94	101-07.94	26.7.94
----------	----------	-----------	---------

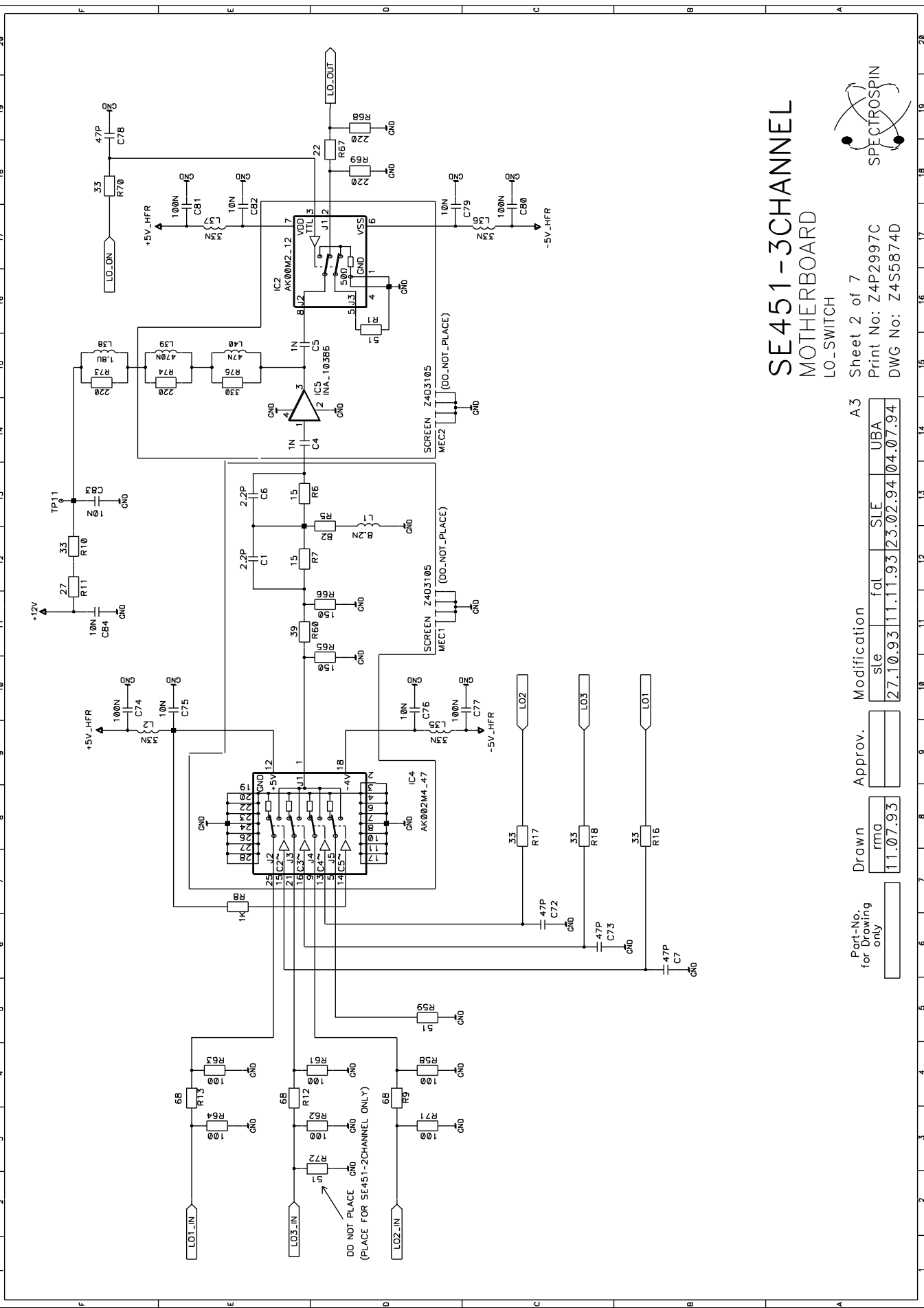

SE451-3CHANNEL MOTHERBOARD LO_SWITCH

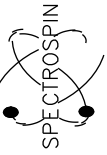

Sheet 2 of 7
Print No: Z4P2997C
DWG No: Z4S5874D

Part-No. for Drawing only	Drawn rma	11.07.93	Approv.	Modification	A3
				sle fal SLE UBA	
		27.10.93	11.11.93	23.02.94	04.07.94

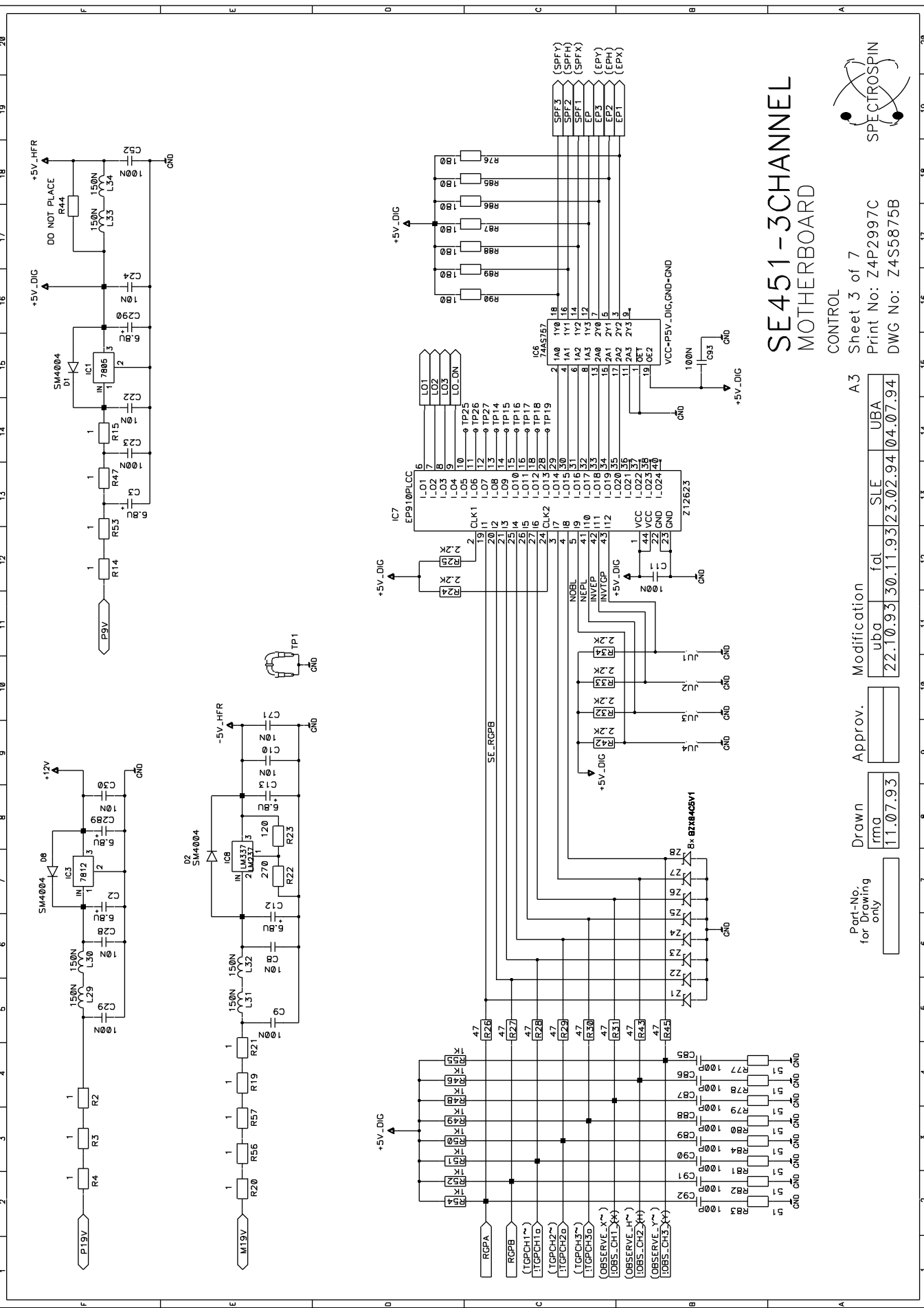

SE451-3CHANNEL MOTHERBOARD

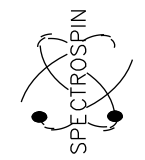

CONTROL
Sheet 3 of 7
Print No: Z4P2997C
DWG No: Z4S5875B

Part-No. for Drawing only	Drawn rma	Approv.	Modification uba	SLE	UBA
	11.07.93		30.11.93	23.02.94	04.07.94

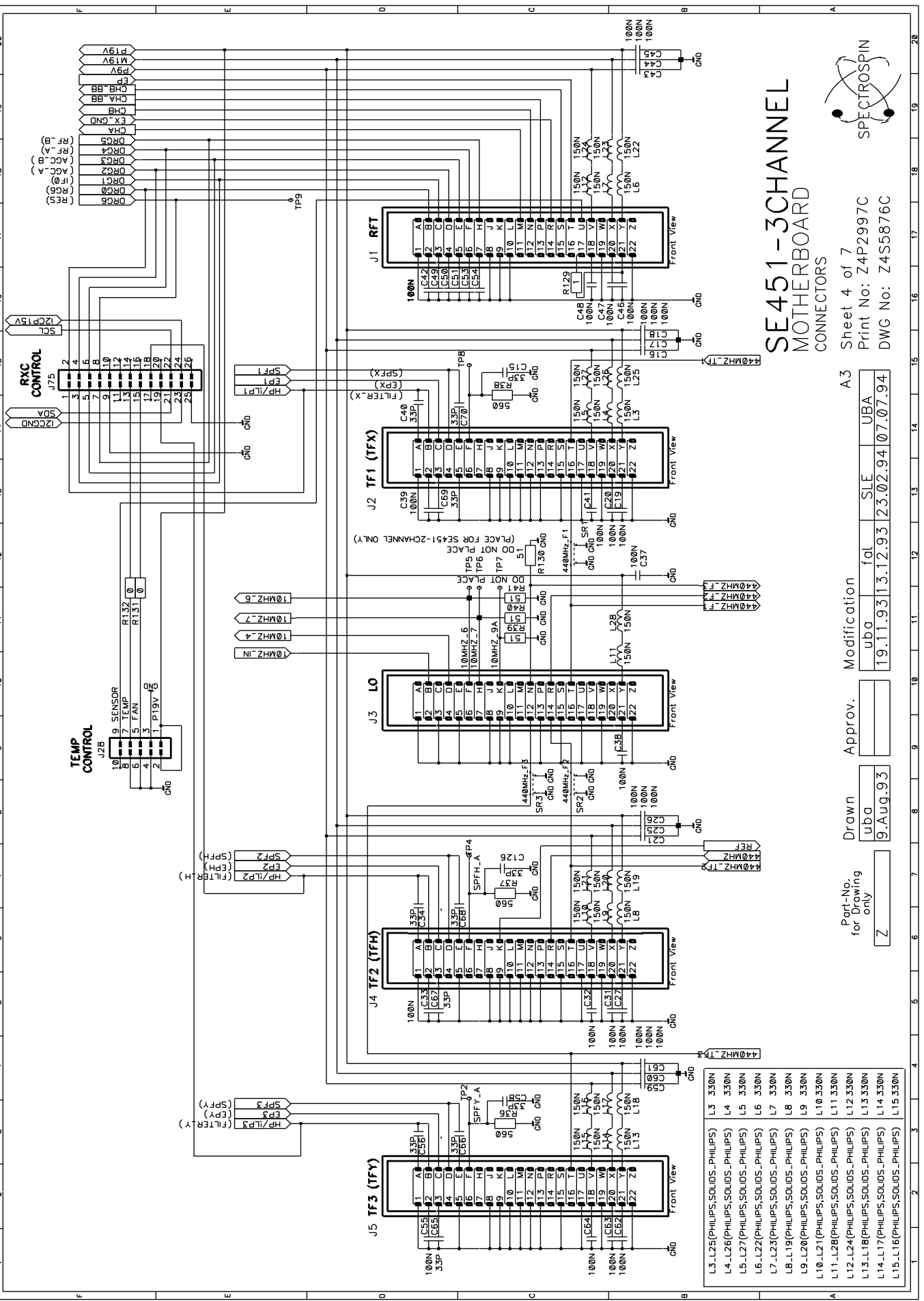

SE451-3CHANNEL MOTHERBOARD CONNECTORS

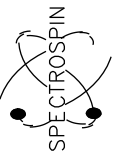

Sheet 4 of 7
Print No: Z4P2997C
DWG No: Z4S5876C

A3

Modification	uho	fad	SLE	UBA
Drawn	uho			
Approv.				
Part-No. for Drawing only	Z			

L3.L25(PHILIPS.SOLIDUS.-PHILIPS)	L3	330N
L4.L26(PHILIPS.SOLIDUS.-PHILIPS)	L4	330N
L5.L27(PHILIPS.SOLIDUS.-PHILIPS)	L5	330N
L6.L22(PHILIPS.SOLIDUS.-PHILIPS)	L6	330N
L7.L23(PHILIPS.SOLIDUS.-PHILIPS)	L7	330N
L8.L19(PHILIPS.SOLIDUS.-PHILIPS)	L8	330N
L9.L20(PHILIPS.SOLIDUS.-PHILIPS)	L9	330N
L10.L21(PHILIPS.SOLIDUS.-PHILIPS)	L10	330N
L11.L28(PHILIPS.SOLIDUS.-PHILIPS)	L11	330N
L12.L24(PHILIPS.SOLIDUS.-PHILIPS)	L12	330N
L13.L18(PHILIPS.SOLIDUS.-PHILIPS)	L13	330N
L14.L17(PHILIPS.SOLIDUS.-PHILIPS)	L14	330N
L15.L16(PHILIPS.SOLIDUS.-PHILIPS)	L15	330N

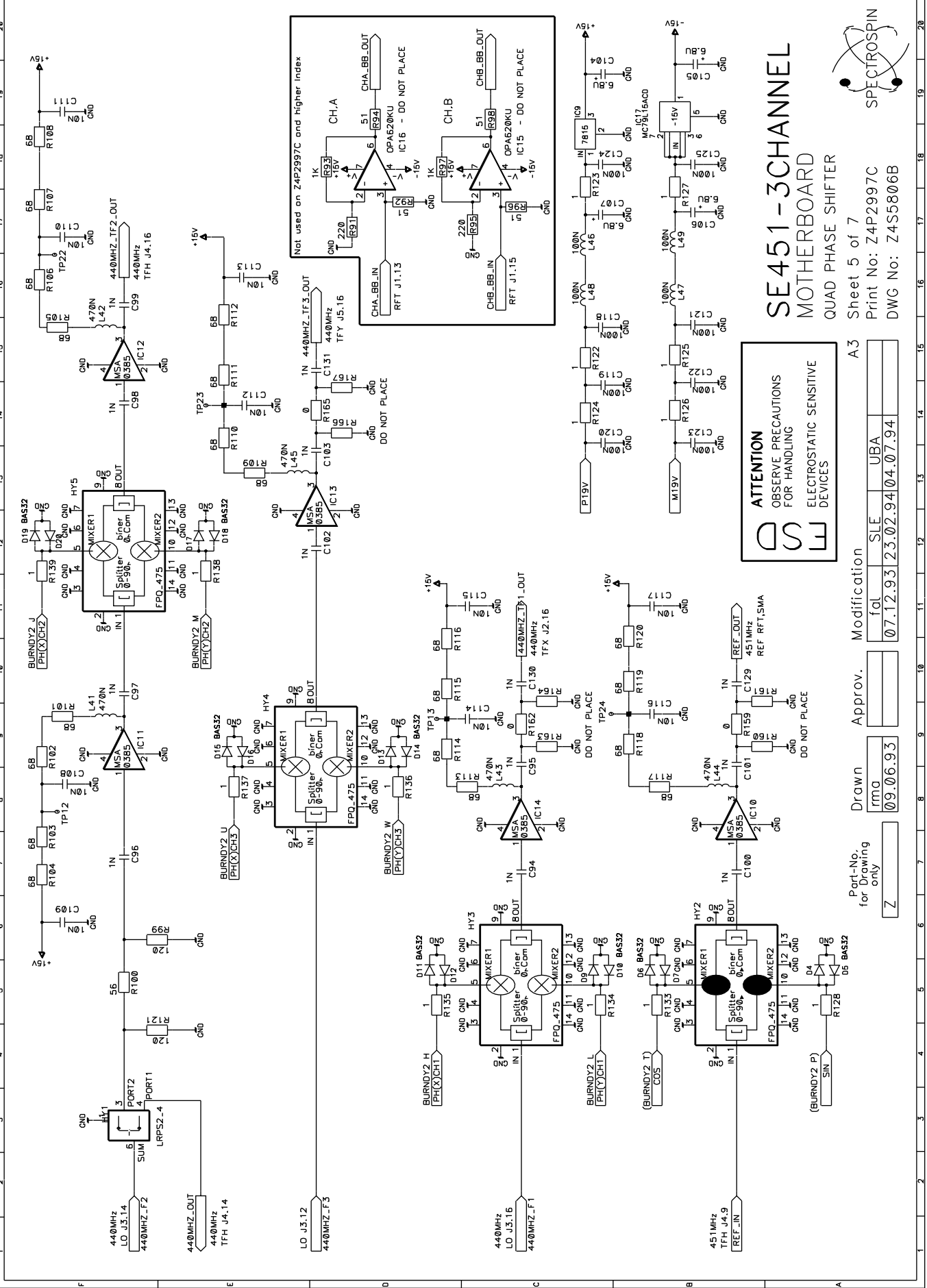

ATTENTION
OBSERVE PRECAUTIONS
FOR HANDLING
ELECTROSTATIC SENSITIVE
DEVICES

SE451-3CHANNEL
MOTHERBOARD
QUAD PHASE SHIFTER

Sheet 5 of 7
Print No: Z4P2997C
DWG No: Z4S5806B

Part-No. for Drawing only	Drawn	Approv.	Modification	A3
Z	rma		fal SLE UBA	
	09.06.93		07.12.93 23.02.94 04.07.94	

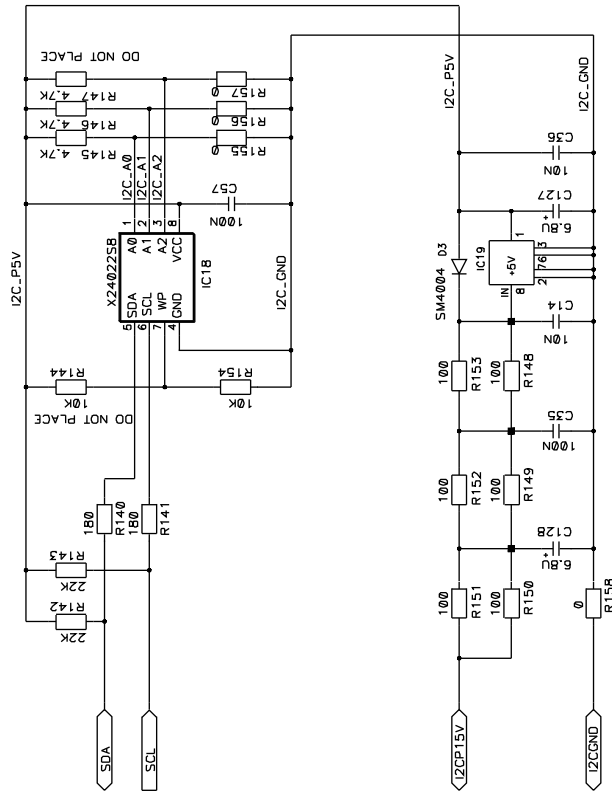

SE451-3CHANNEL MOTHERBOARD

BBIS

Sheet 7 of 7
Print No: Z4P2997C
DWG No: Z4S5973

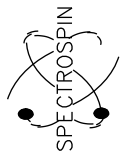

Part-No. for Drawing only	Drawn ubo	Approv.	Modification	A3
	04.07.94			

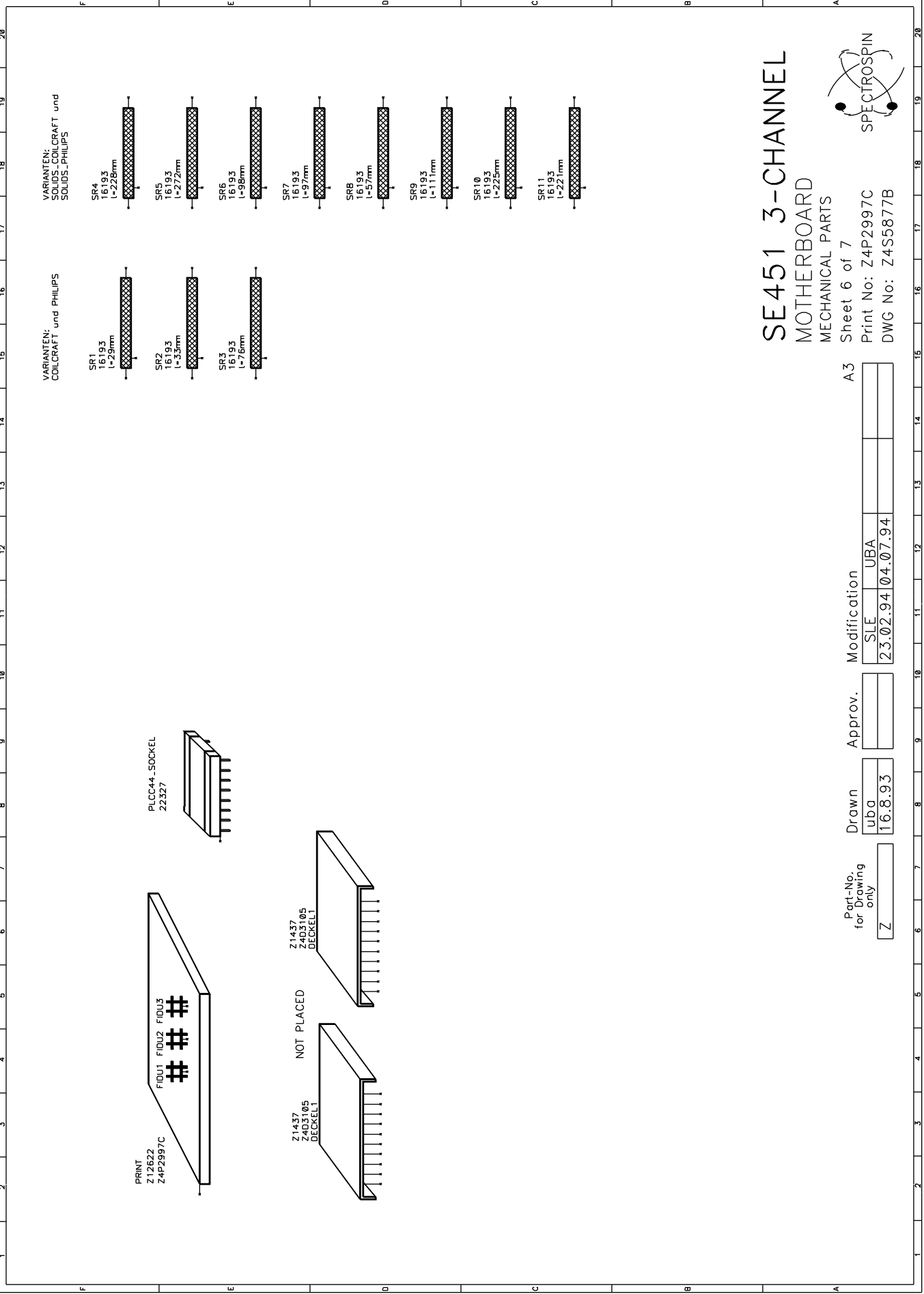

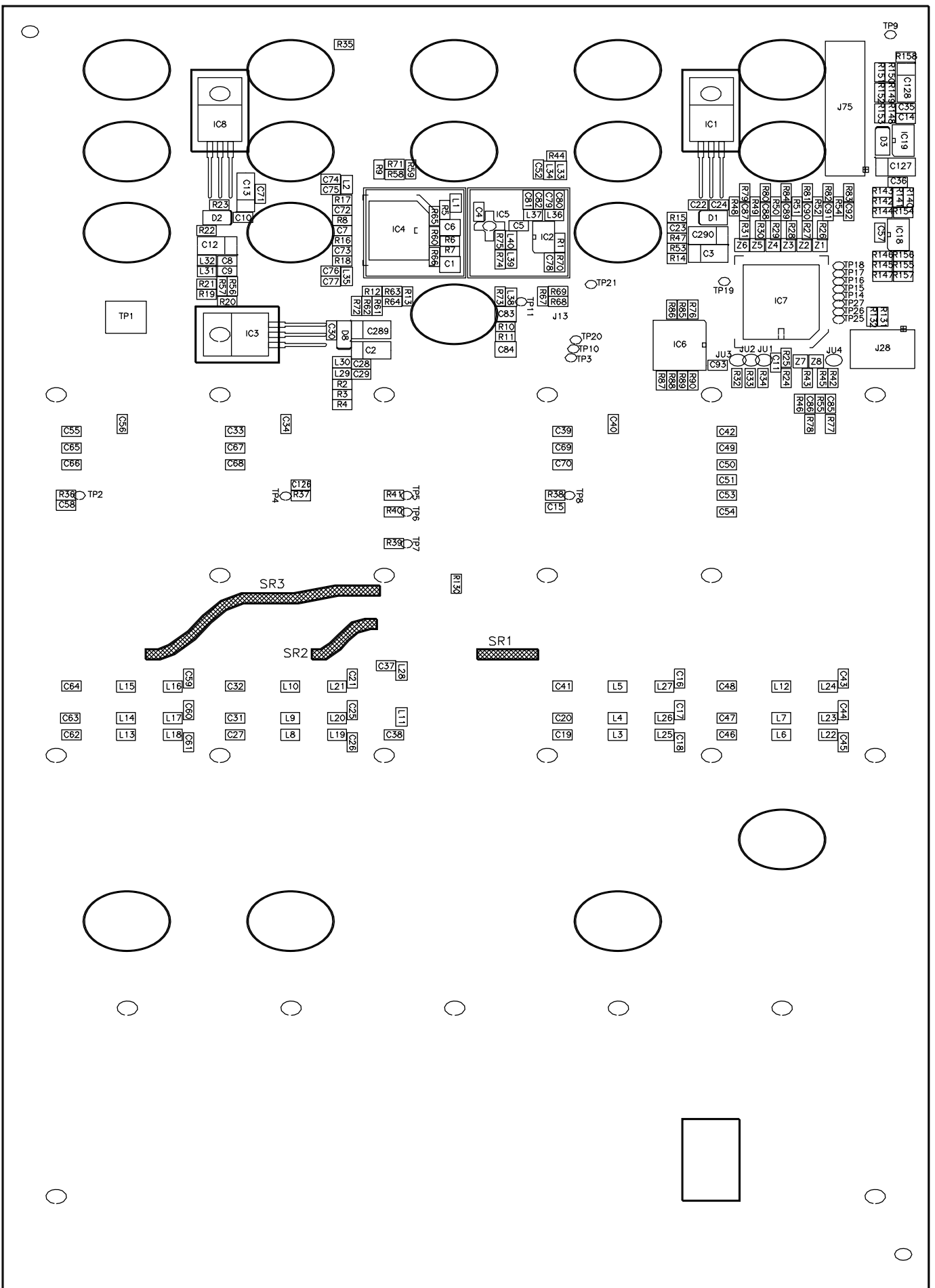

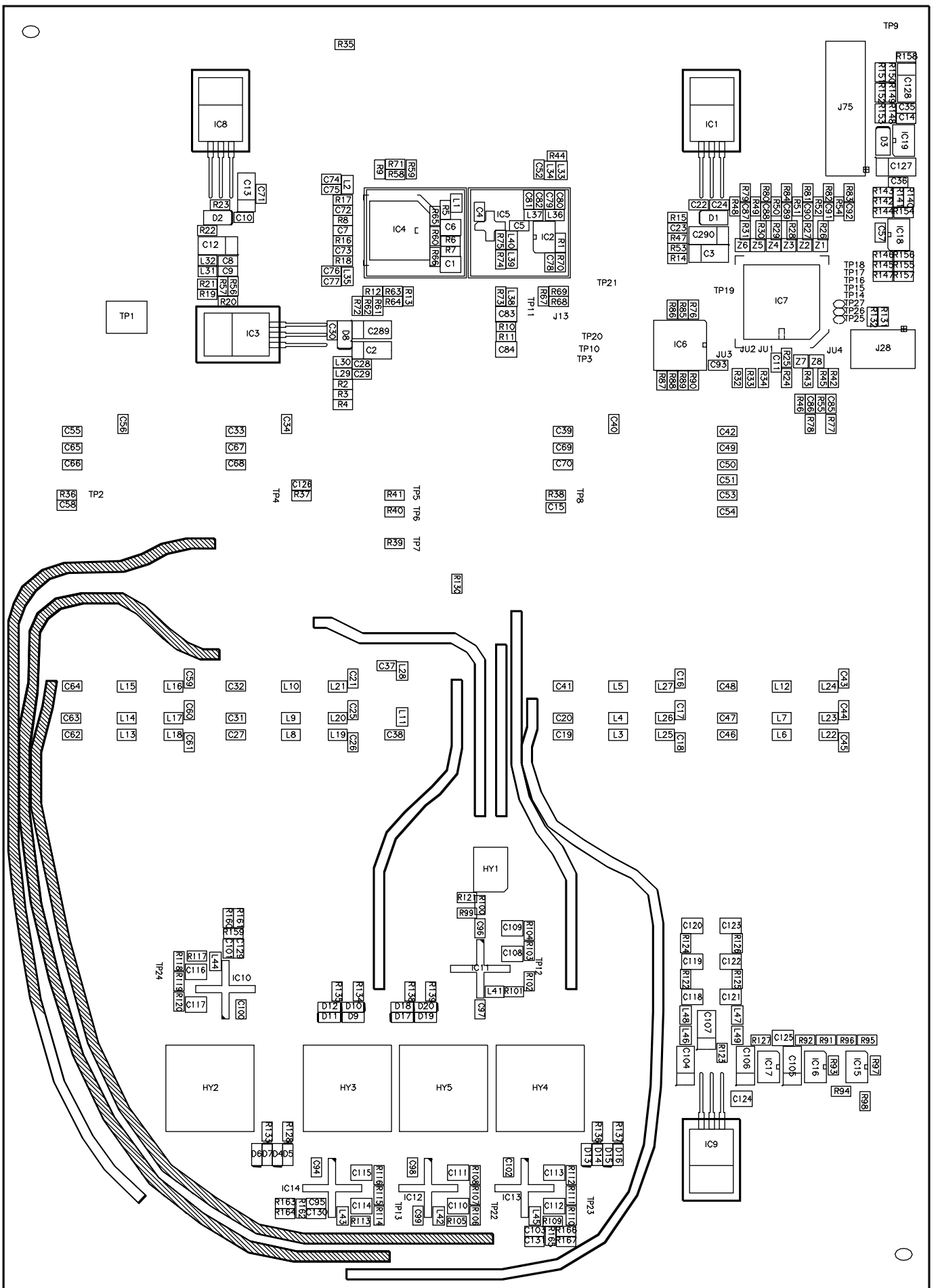

On the following pages you will find the schematics of the SE451-3CH I2C Piggy Back Board (Z4P3031) which implements the BBIS (BRUKER Board Information System) for motherboard versions with Index A and B (Z4P2997A and Z4P2997B).



Figure 18: BBIS Piggy-Back .

Schematics BBIS Board

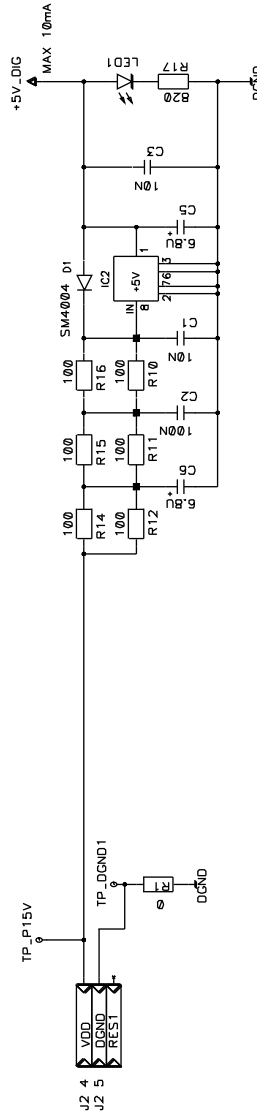
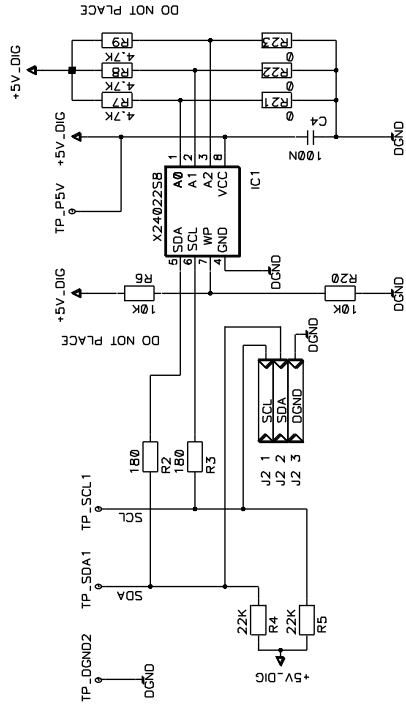
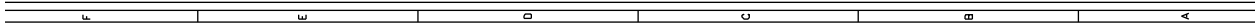

SE451
 PIGGY BOARD
 I2C OPTION
 Sheet 1 of 1
 Print No: Z4P30031

Part-No. for Drawing only	Drawn rma	Approved	Modification	A3
---------------------------------	--------------	----------	--------------	----

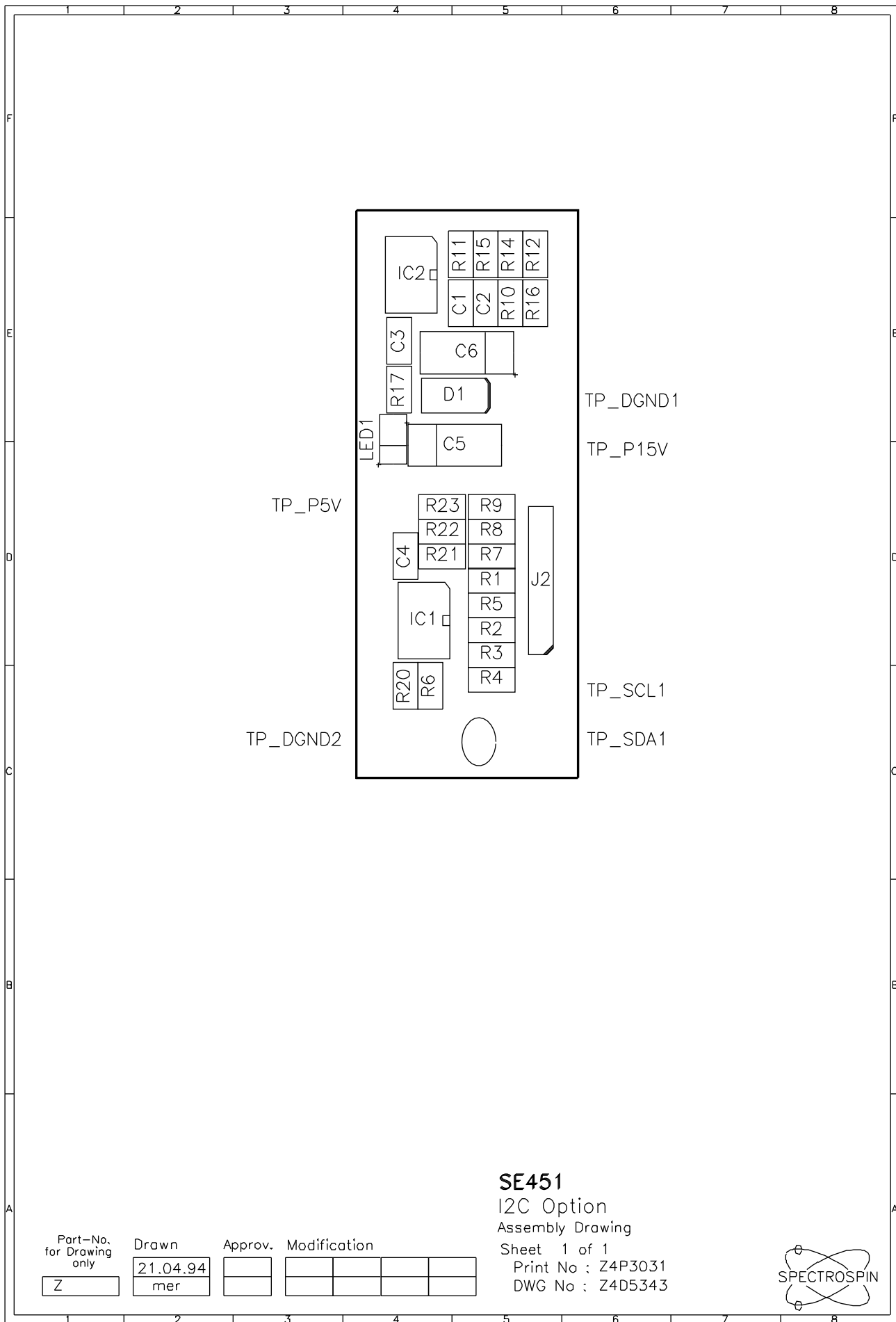

Part-No.
for Drawing
only

Z

Drawn

21.04.94
mer

Approv.

Modification

SE451

I2C Option

Assembly Drawing

Sheet 1 of 1

Print No : Z4P3031

DWG No : Z4D5343



On the following pages you will find the schematics of the SE451-3CH temperature controller board Z4P3032B.

Temperature Controller Index A:

The Temp. Contr. board index A is almost identical to the index B described in this chapter. The only difference is the location of the ext. power supply monitor circuit.

Print index Z4P3032B have the monitor circuit on board, whereas index A boards have an extra piggy-back print with the same function. The circuit itself is the same.

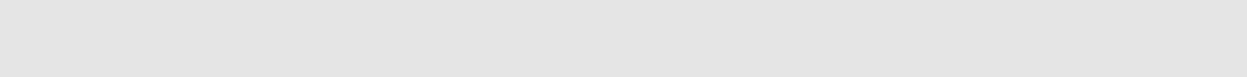
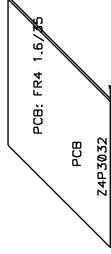
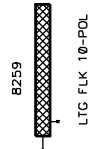
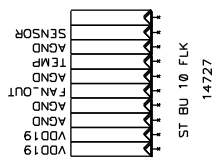
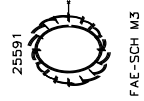
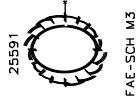
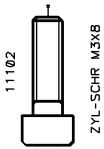
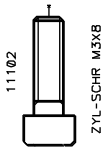
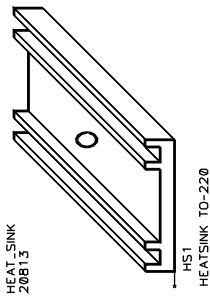

Figure 19: Temperature Controller

/files/home/users/mer/project/se451/temp_controller/MECH_PARTS/1.dwg 22_SEP_94 16:46 Last update: 22_SEP_94 16:44



SE451-3CH

TEMPERATURE CONTROLLER

MECHANICAL PARTS
 Sheet 2 of 2
 Print No: Z4P3032B
 DWG No: Z4S5943B

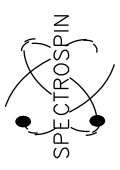

Part-No. for Drawing only	Drawn	Approv.	Modification	A3
	SLE	CSC	MER	
	21.04.94	22.09.94	22.09.94	

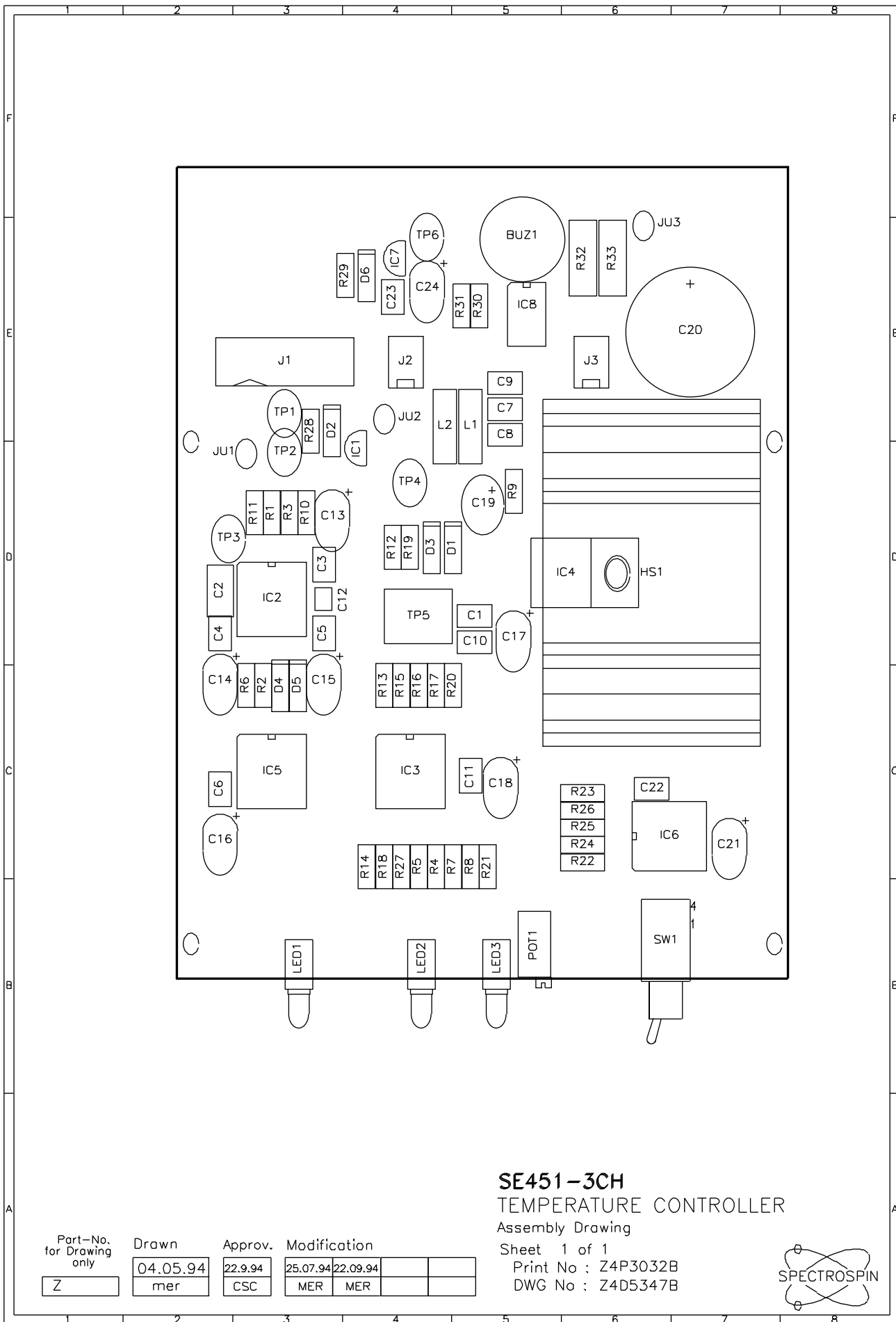

SE451-3CH
TEMPERATURE CONTROLLER
 Assembly Drawing

Sheet 1 of 1
 Print No : Z4P3032B
 DWG No : Z4D5347B

Part-No.
for Drawing
only

Z

Drawn

04.05.94
mer

Approv.

22.9.94
CSC

Modification

25.07.94	22.09.94		
MER	MER		



Schematics Receiver Board14

On the following pages you will find the schematics of the SE451-3CH Receiver Board (Z4P2476F) including the BB-Option (Z4P2762C), the RF-Modul (Z4P2571E) and the QD-Modul (Z4P2573F).

The schematics for the IF-Modul, which is also mounted on the Receiver Board, are not included in this chapter. However you will find the appropriate information in the appendage at the end of this manual.

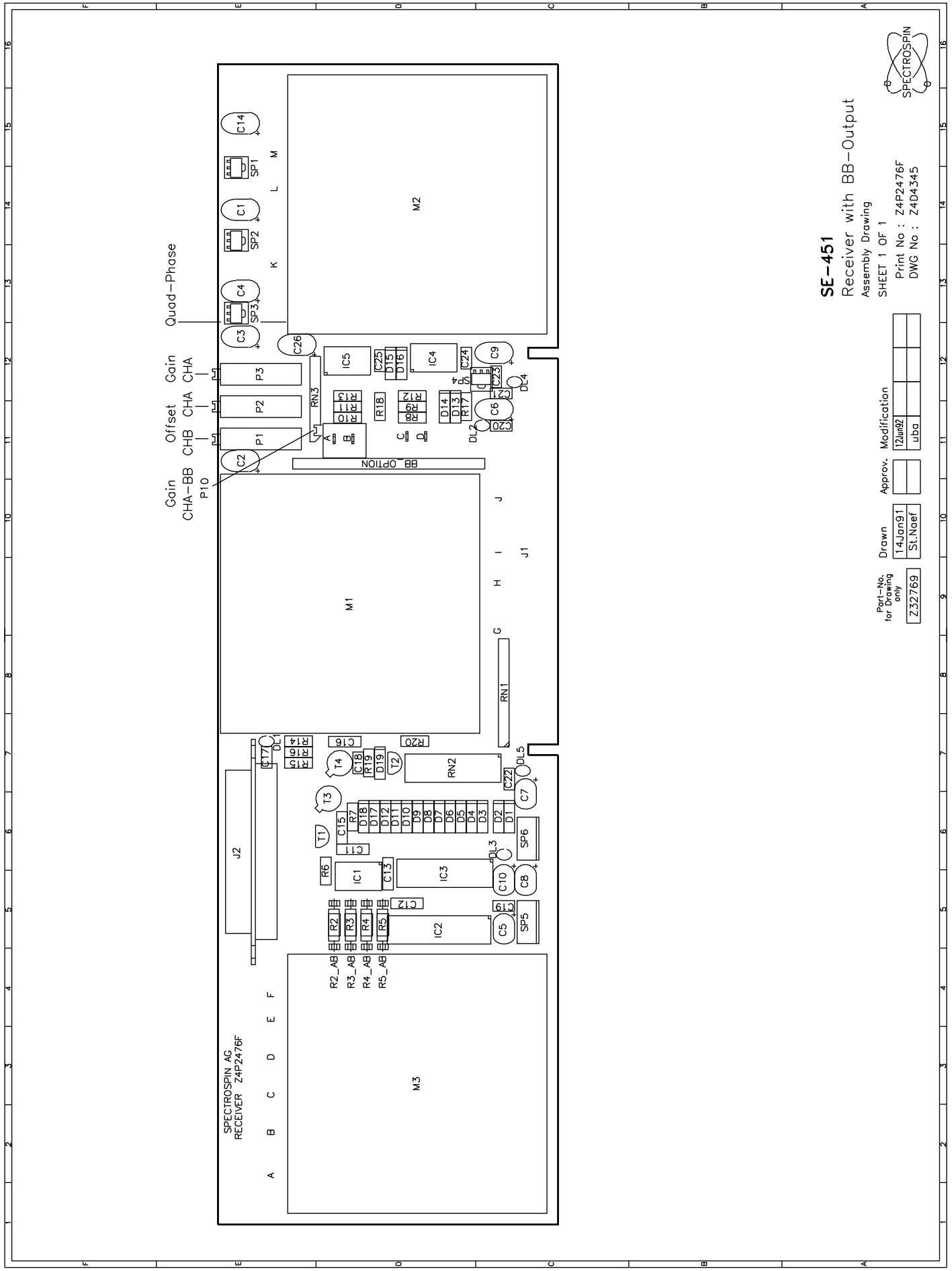

SPECTROSPIN AG
RECEIVER - Z4P2476F

SE-451
Receiver with BB-Output
Assembly Drawing
SHEET 1 OF 1

Print No : Z4P2476F
DWG No : Z4D4345

Part-No. for Drawing only	Drawn	Approv.	Modification
Z32769	14.Jan91 St.Naef		12.Jun92 uba



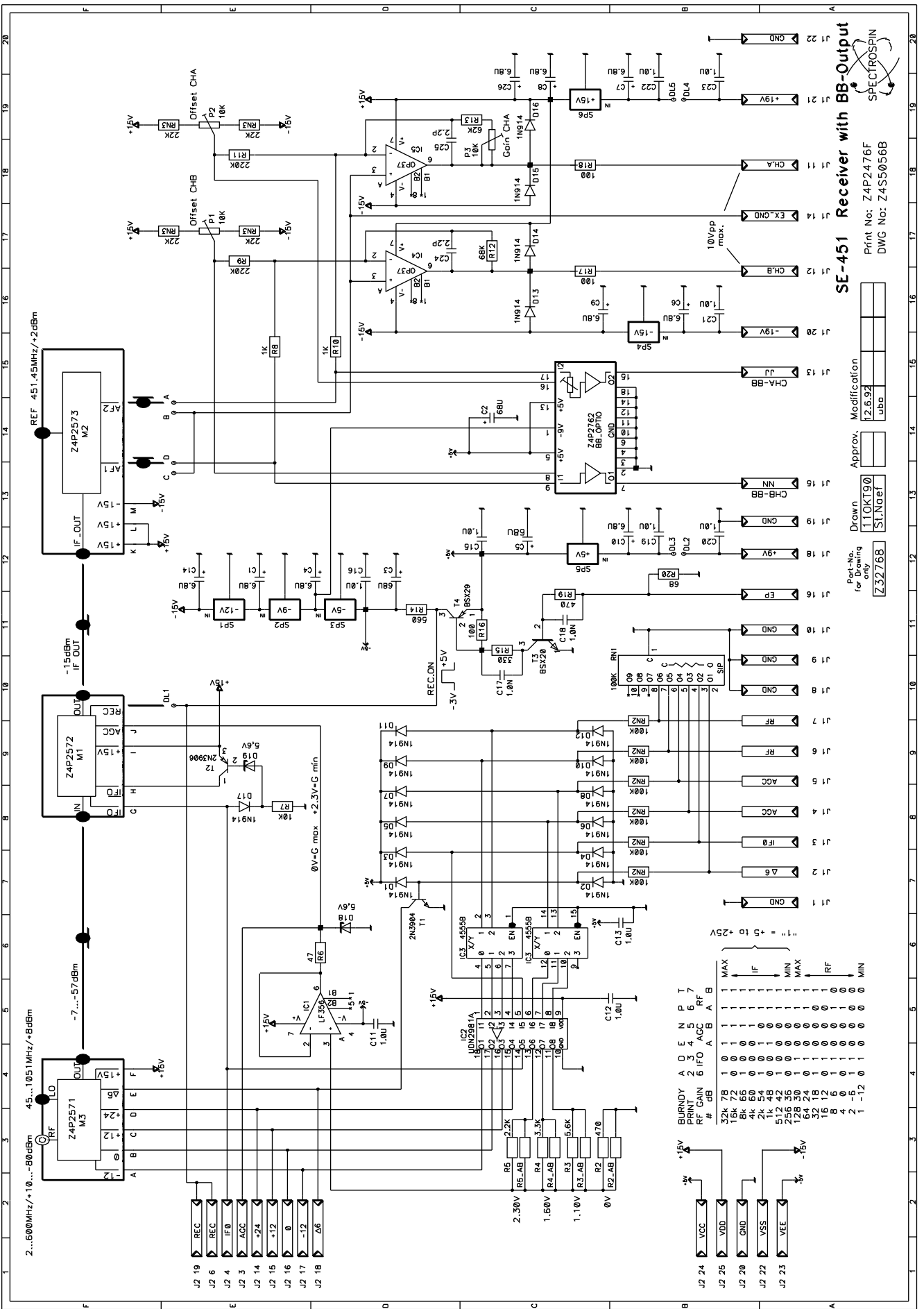

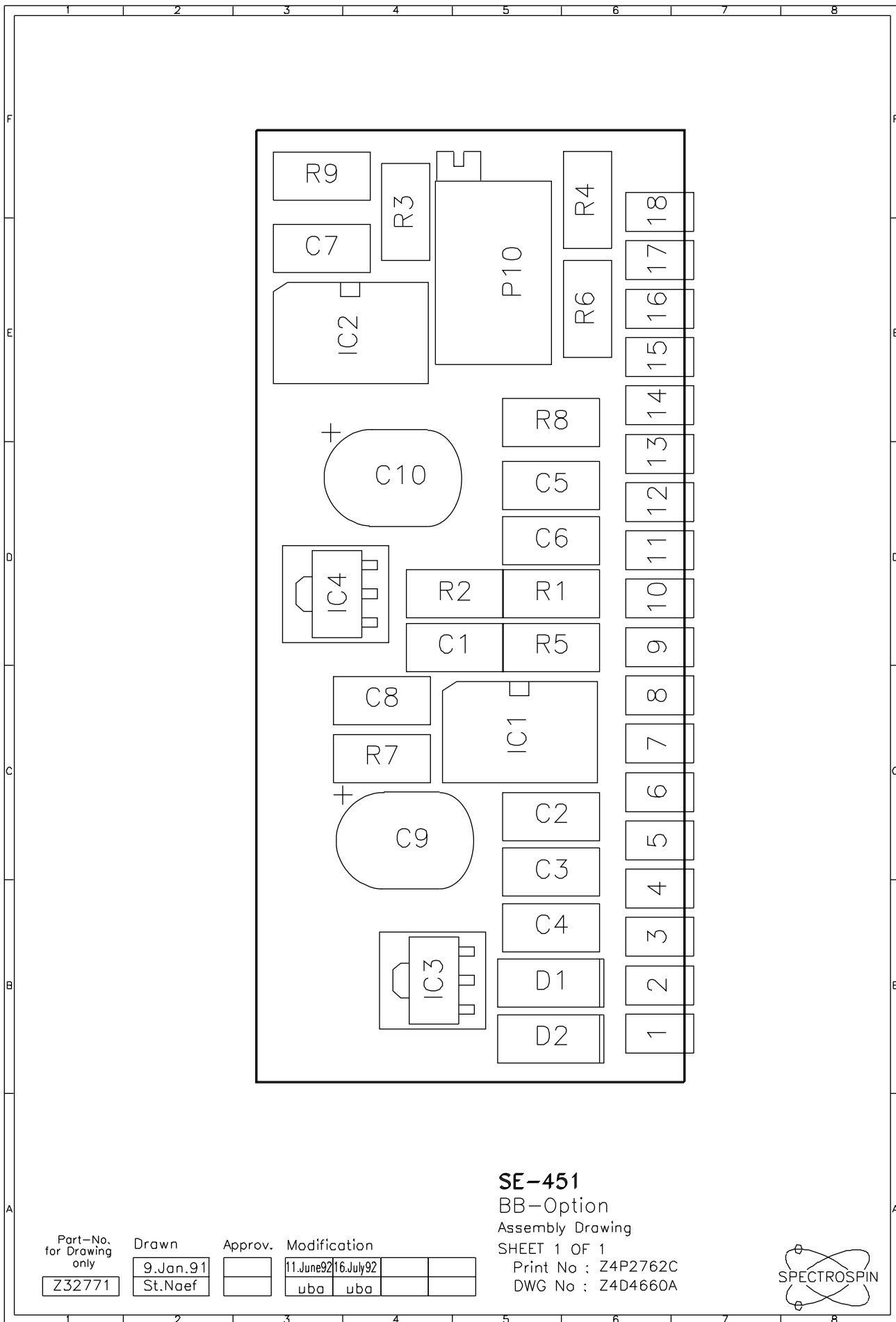

SE-451

BB-Option

Assembly Drawing

SHEET 1 OF 1

Print No : Z4P2762C

DWG No : Z4D4660A

Part-No.
for Drawing
only

Z32771

Drawn

9.Jan.91

St.Naef

Approv.

Modification

11.June92 16.July92

uba uba

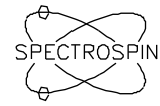

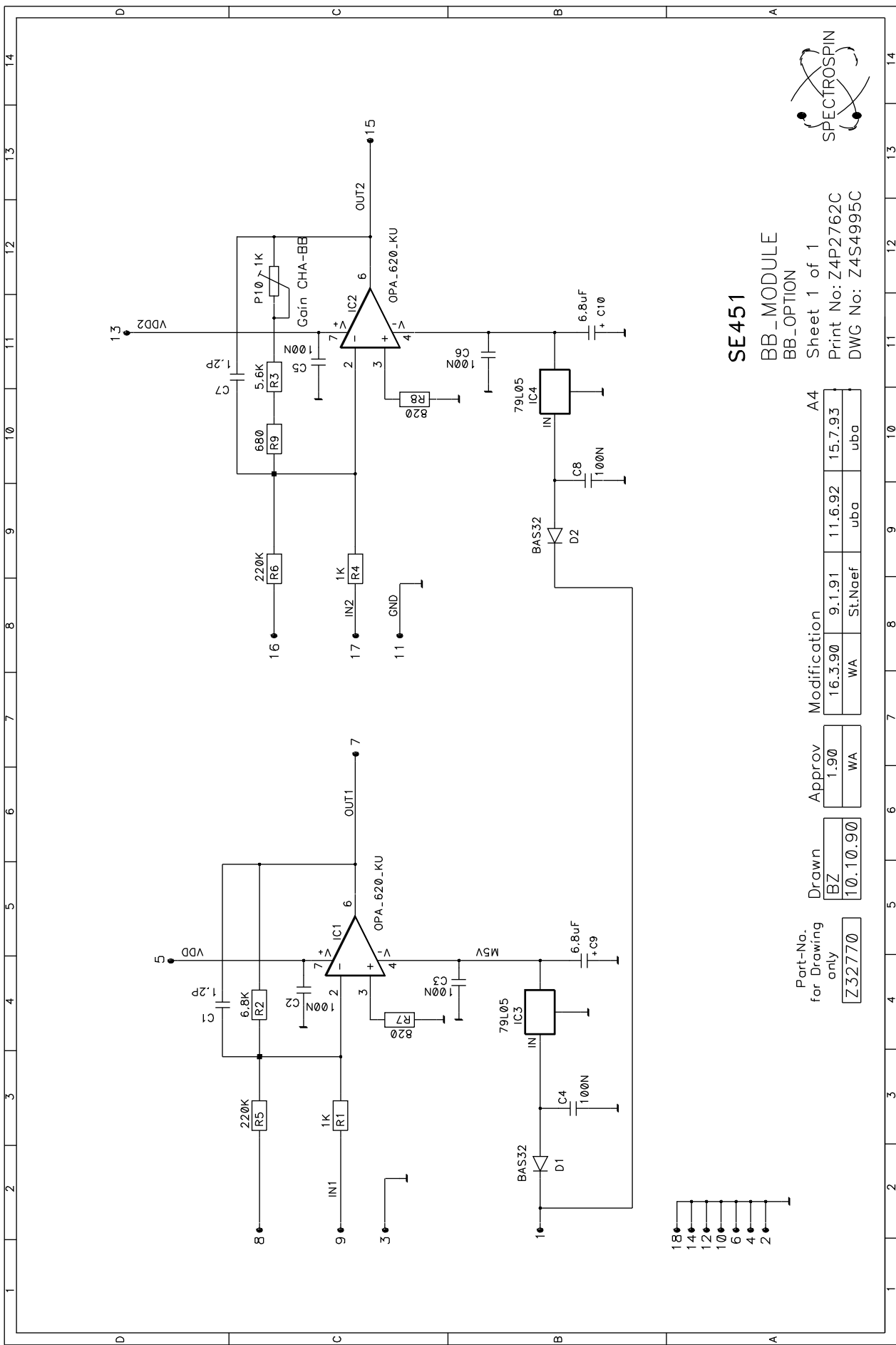

SE451

BB_MODULE
BB-OPTION

Sheet 1 of 1
Print No: Z4P2762C
DWG No: Z4S4995C



Part-No. for Drawing only		Modification		A4	
Z32770	10.10.90	BZ	1.90	16.3.90	9.1.91
			WA	SLNaef	uba
				11.6.92	15.7.93
				uba	uba

/Res/home/users/mez/project/se451/RECEIVER_RF/1.drw 29 SEP 94 09:20 Lost update: 29 SEP 94 09:19

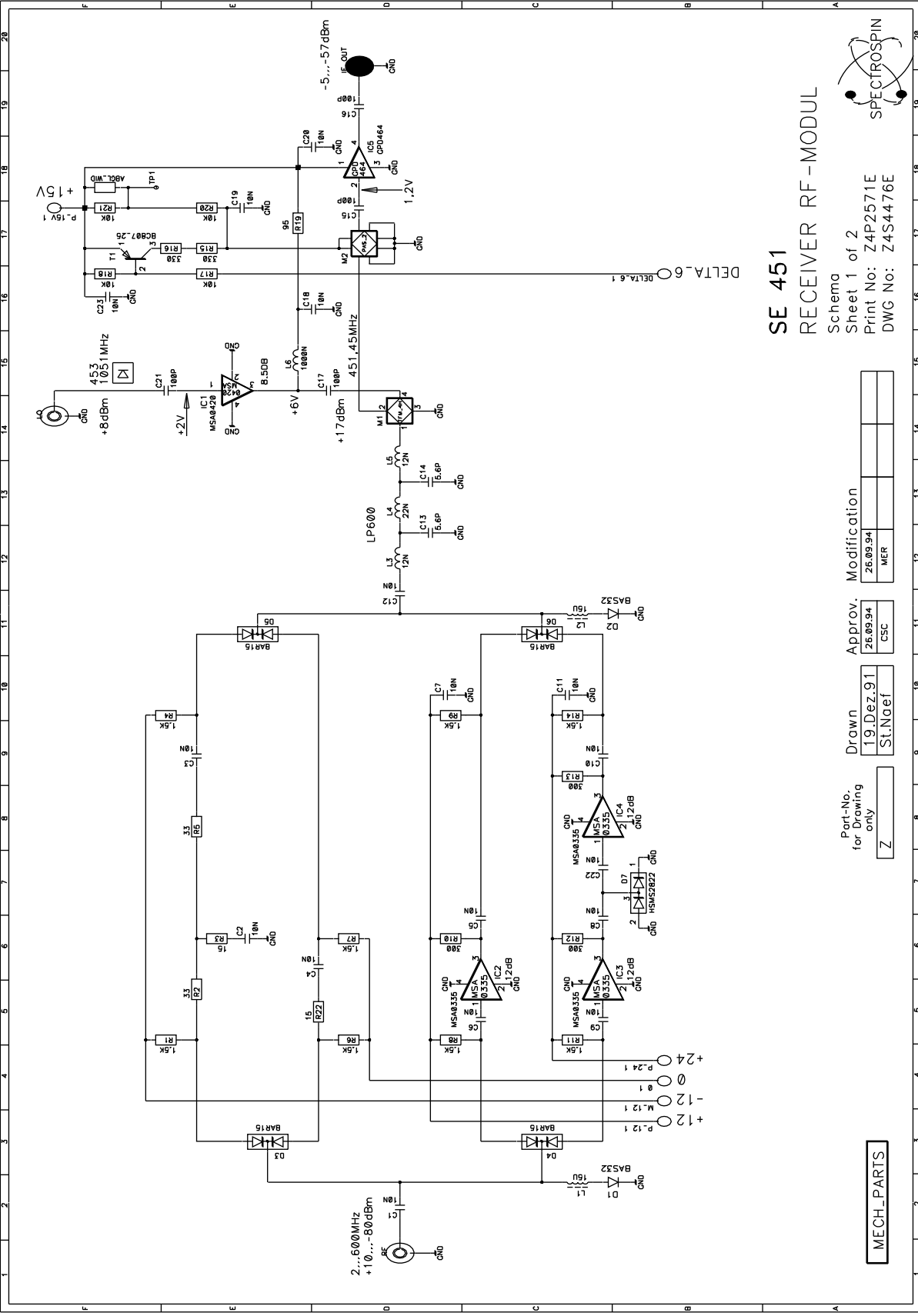

SE 451
RECEIVER RF-MODUL

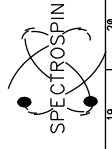

Schema
 Sheet 1 of 2
 Print No: Z4P2571E
 DWG No: Z4S4476E

Part-No.	Drawn	Approv.	Modification
Z	19.Dez.91 St.Noef	26.09.94 CSC	26.09.94 MER

MECH-PARTS

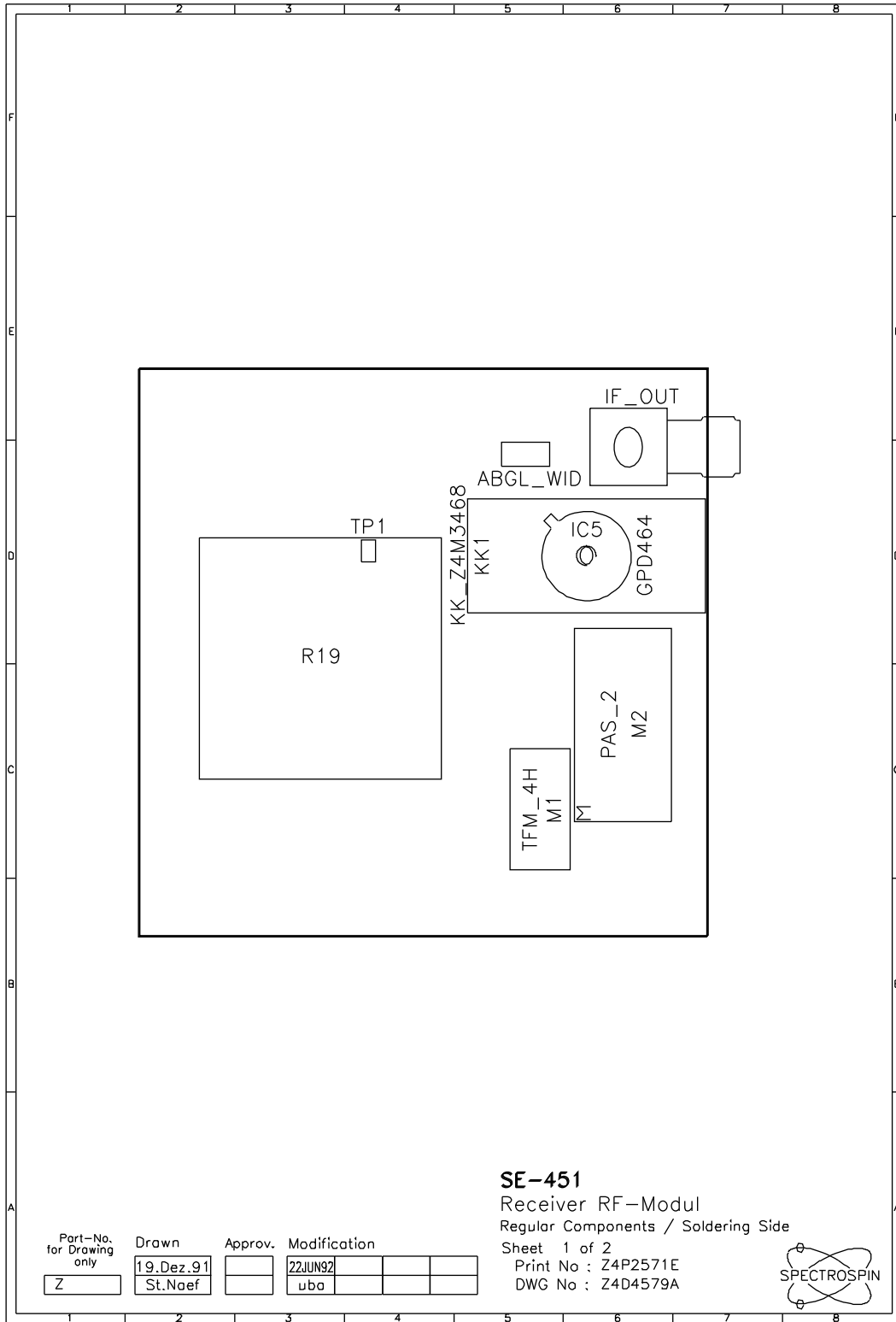

SE-451

Receiver RF-Modul

Regular Components / Soldering Side

Sheet 1 of 2

Print No : Z4P2571E

DWG No : Z4D4579A



Part-No.
for Drawing
only

Z

Drawn

19.Dez.91
St.Naef

Approv.

Modification

22JUN92		
uba		

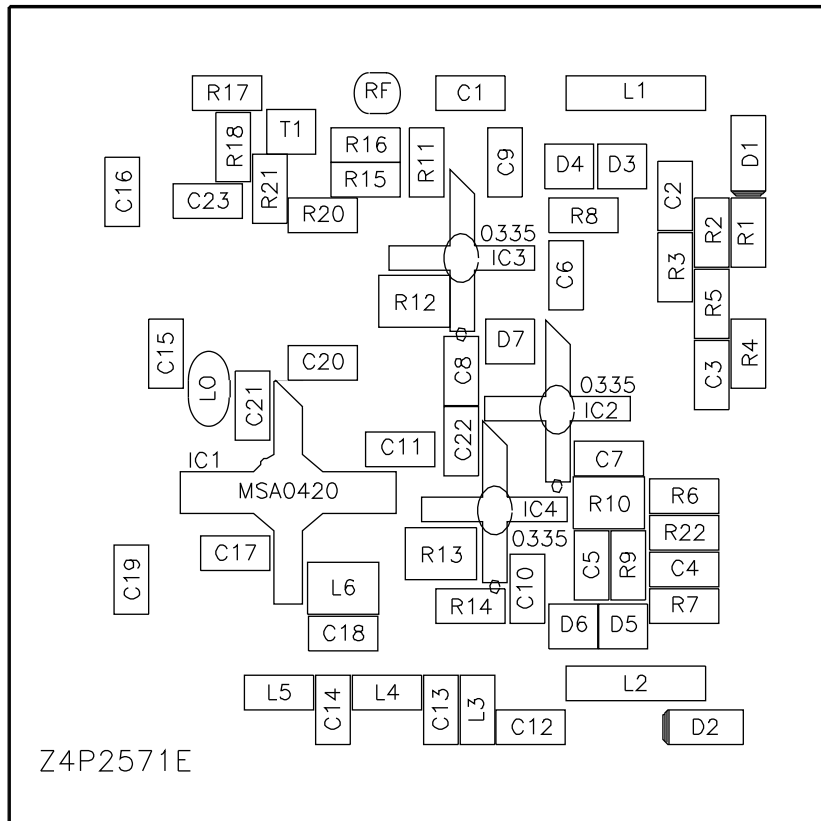

Part-No.
for Drawing
only

Z

Drawn

19.Dez.91
St.Naef

Approv.

29.09.94
CSC

Modification

29.09.94		
MER		

SE-451

Receiver RF-Modul

Assembly Drawing - SMD Components

Sheet 2 of 2

Print No : Z4P2571E

DWG No : Z4D4574A

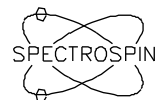

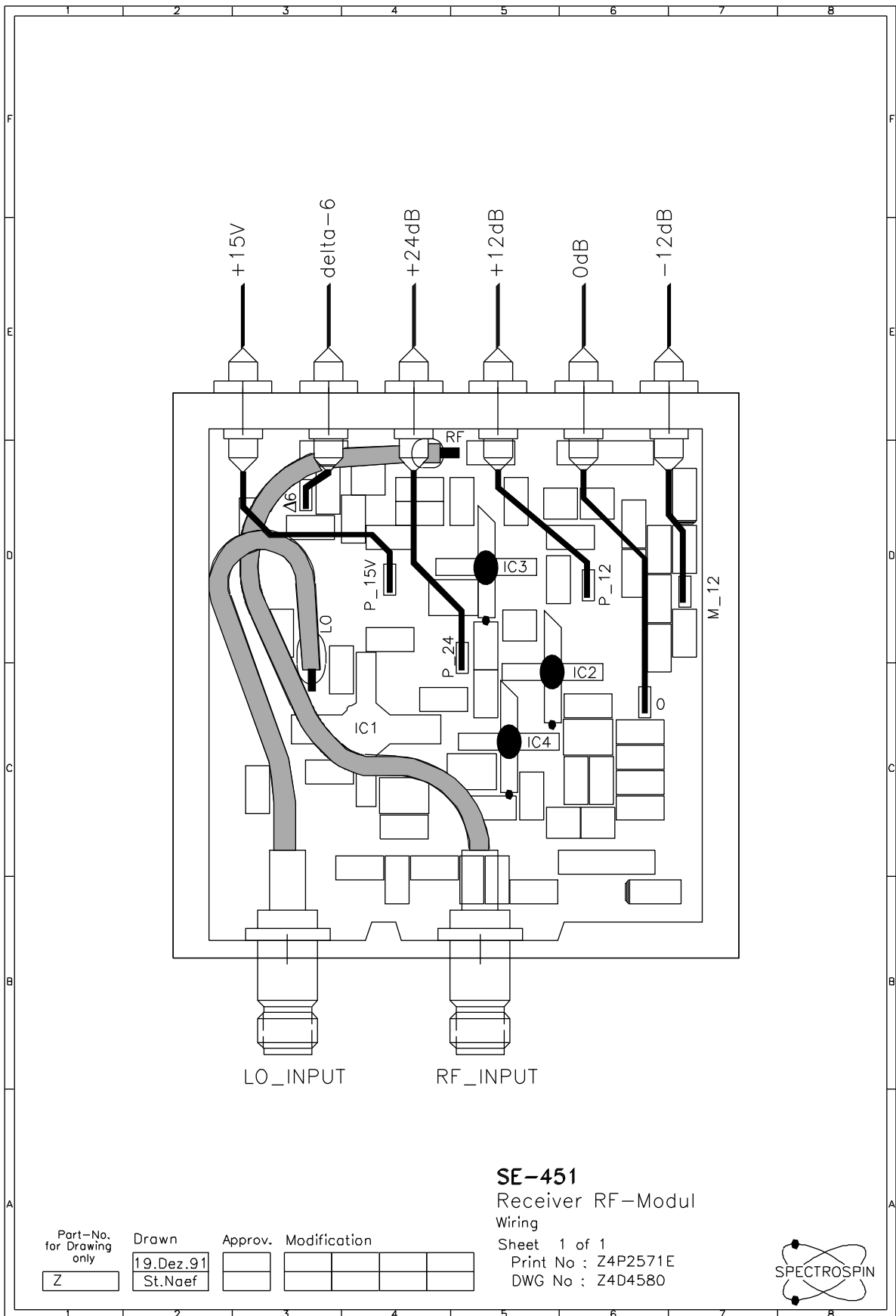

/files/home/users/bz/QD/1.drw 29 OCT 90 15:16 lost update: 29 OCT 90 15:01

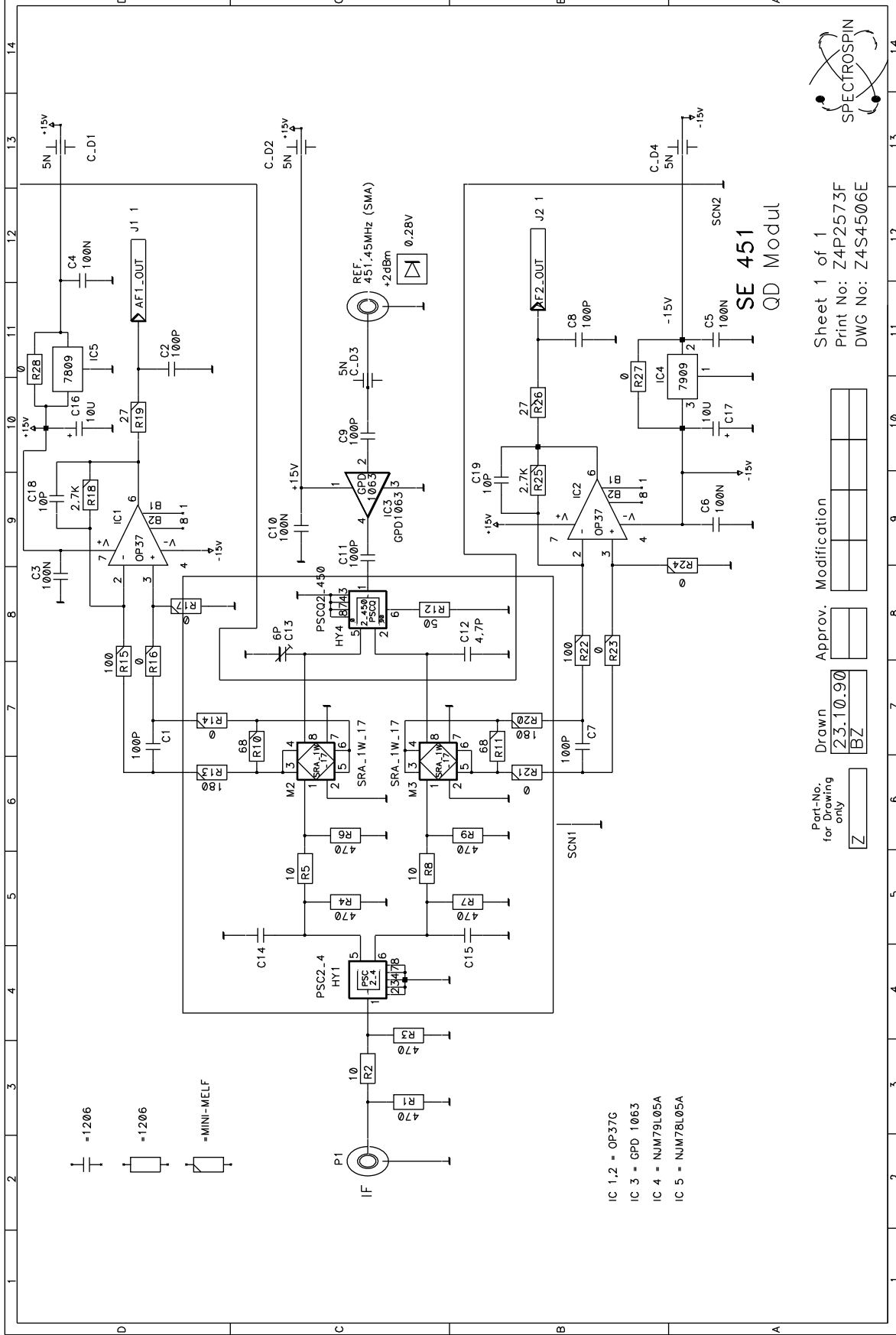

Sheet 1 of 1
Print No: Z4P2573F
DWG No: Z4S4506E

Part-No. for Drawing only	Drawn	Approv.	Modification
Z	23.10.90 BZ		

SE 451
QD Modul

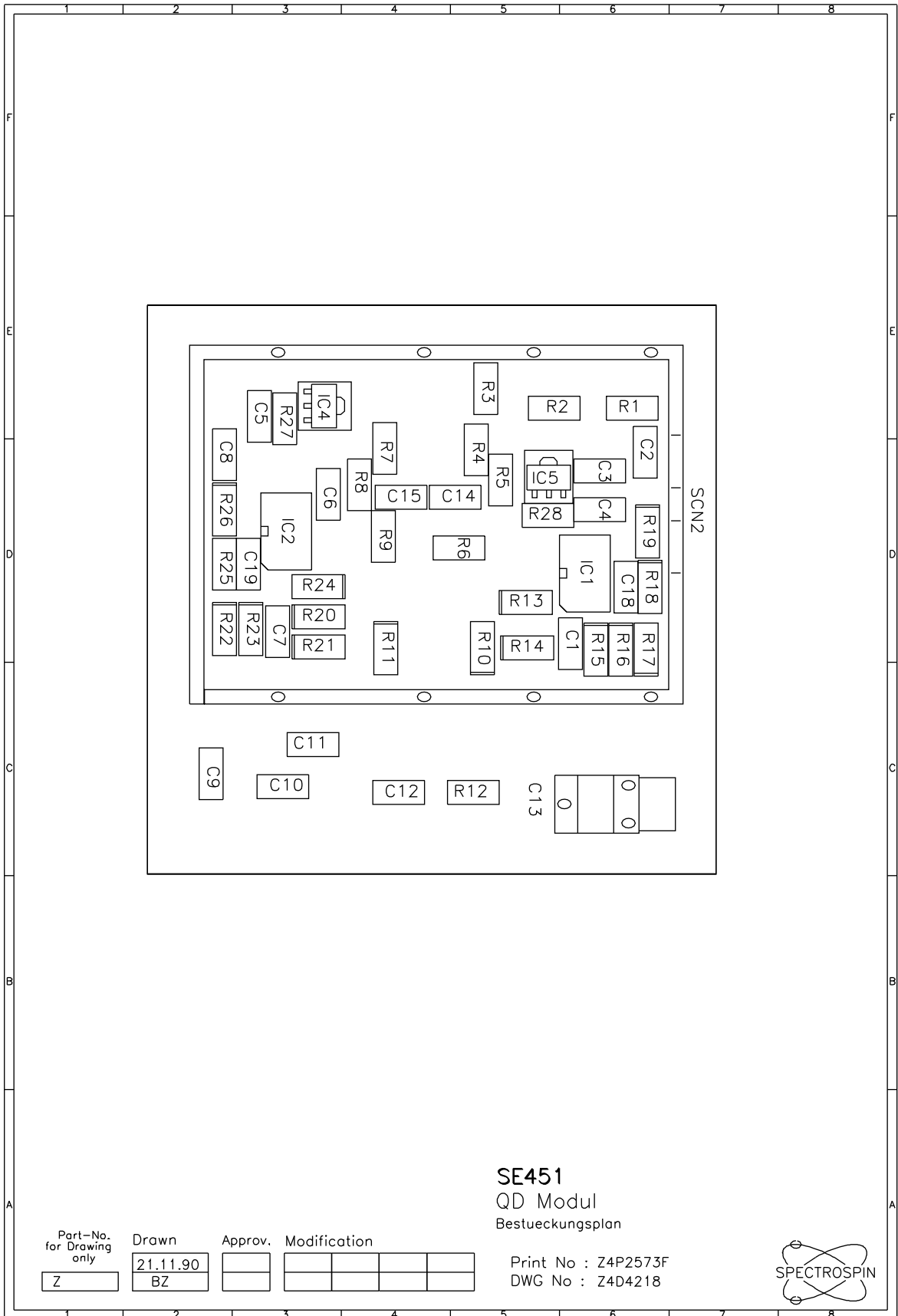

SE451
 QD Modul
 Bestueckungsplan

Part-No. for Drawing only	Drawn	Approv.	Modification
Z	21.11.90 BZ		

Print No : Z4P2573F
 DWG No : Z4D4218

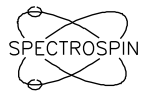

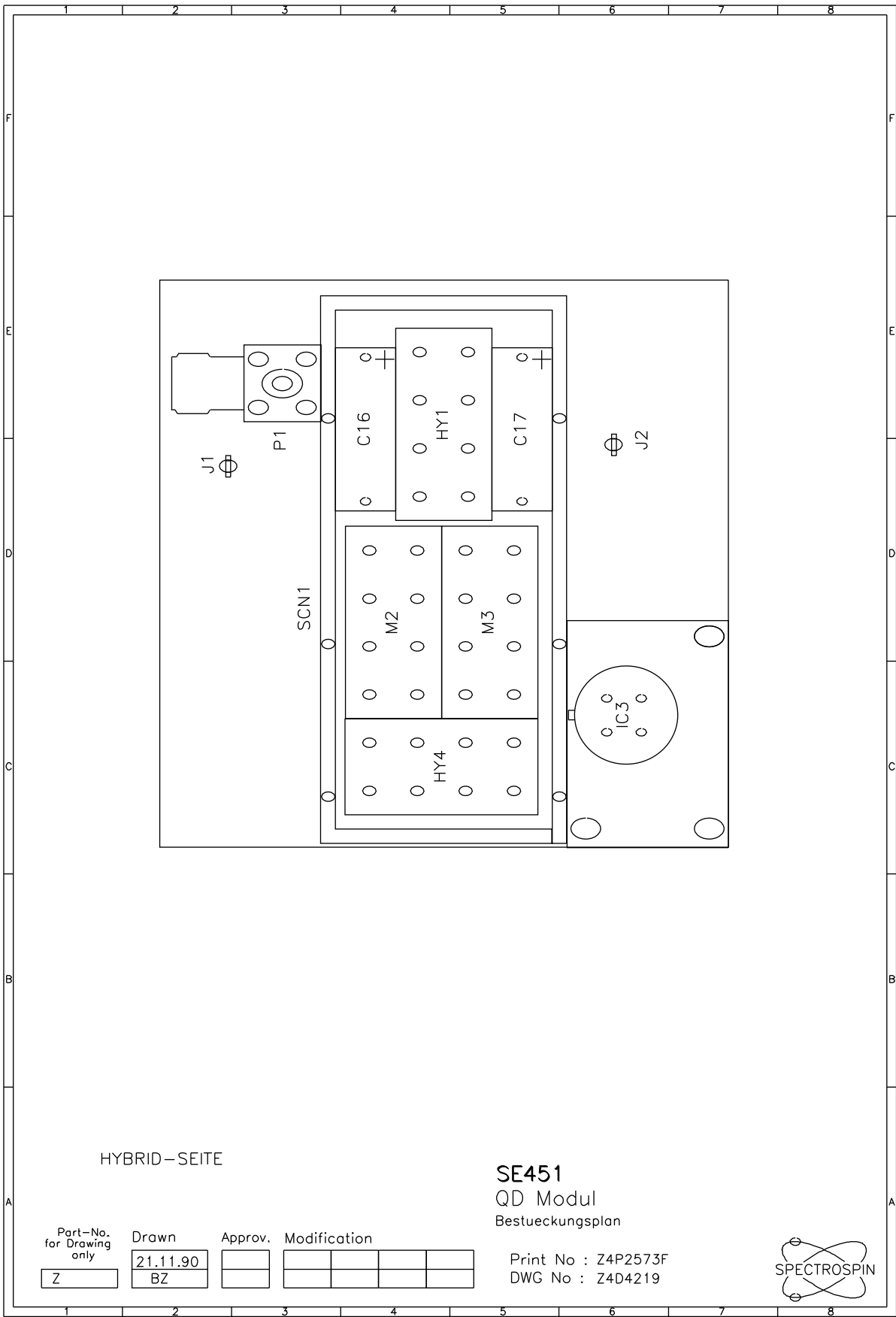

HYBRID-SEITE

SE451
 QD Modul
 Bestueckungsplan

Part-No.
for Drawing
only

Z

Drawn

21.11.90

BZ

Approv.

Modification

--	--	--	--	--

Print No : Z4P2573F
 DWG No : Z4D4219

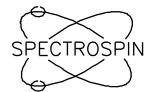

On the following pages you will find the schematics of the Local Oszillator Board II (Z4P3011A) including the SAW-Oszillator (Z4P3024).

The SAW-Oszillator itself contains the Oszillator (Z4P3000A), the Driver (Z4P3001A) and the 3rd Output (Z4P2998A).

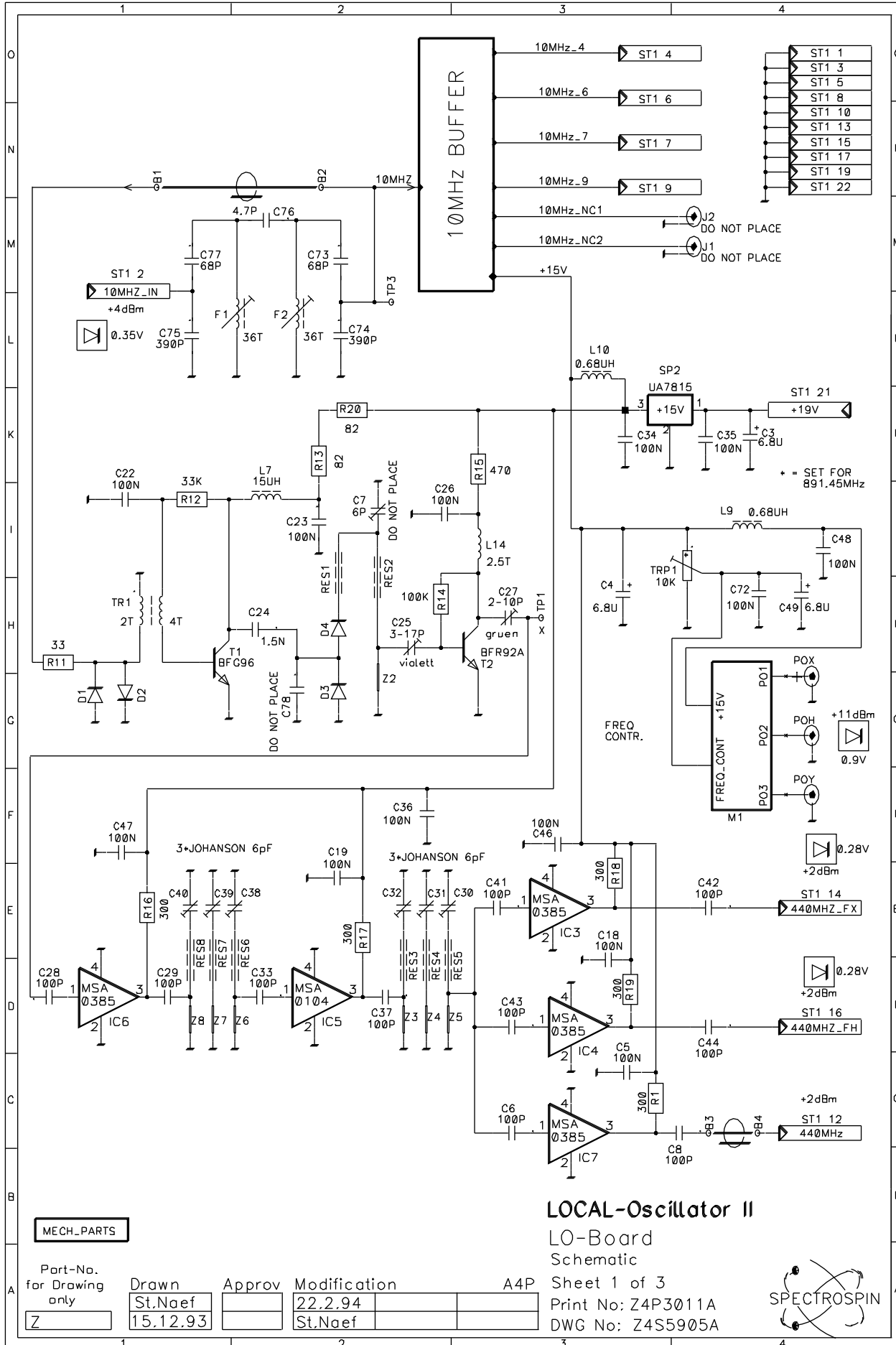

MECH_PARTS

Part-No. for Drawing only	Drawn	Approv	Modification	A4P
Z	St.Naef 15.12.93		22.2.94 St.Naef	

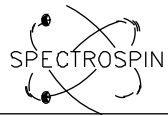

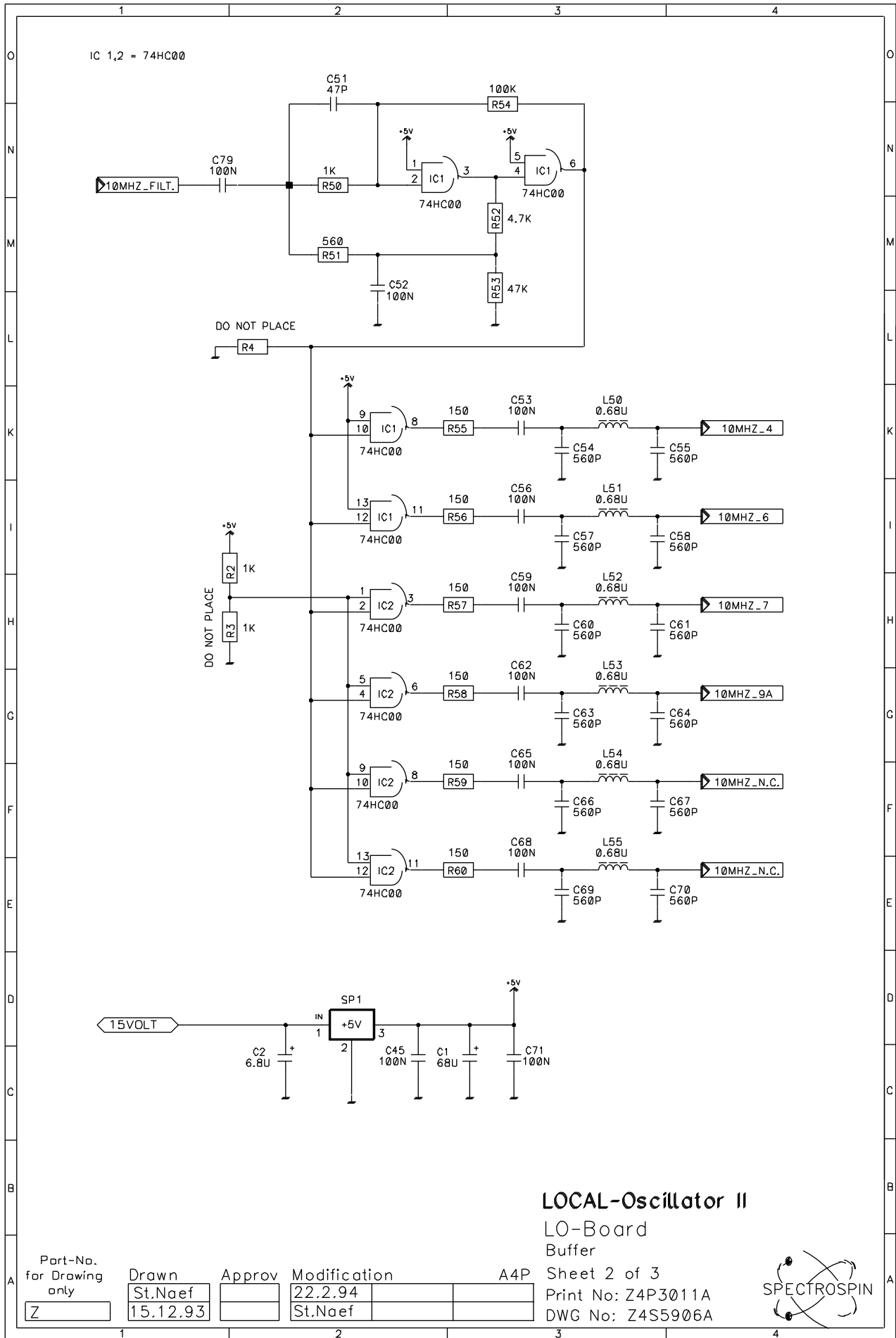

LOCAL-Oscillator II

LO-Board
Buffer

Part-No.
for Drawing
only
Z

Drawn
St.Naef
15.12.93

Approv
[]

Modification
22.2.94
St.Naef

A4P
[]
[]

Sheet 2 of 3
Print No: Z4P3011A
DWG No: Z4S5906A



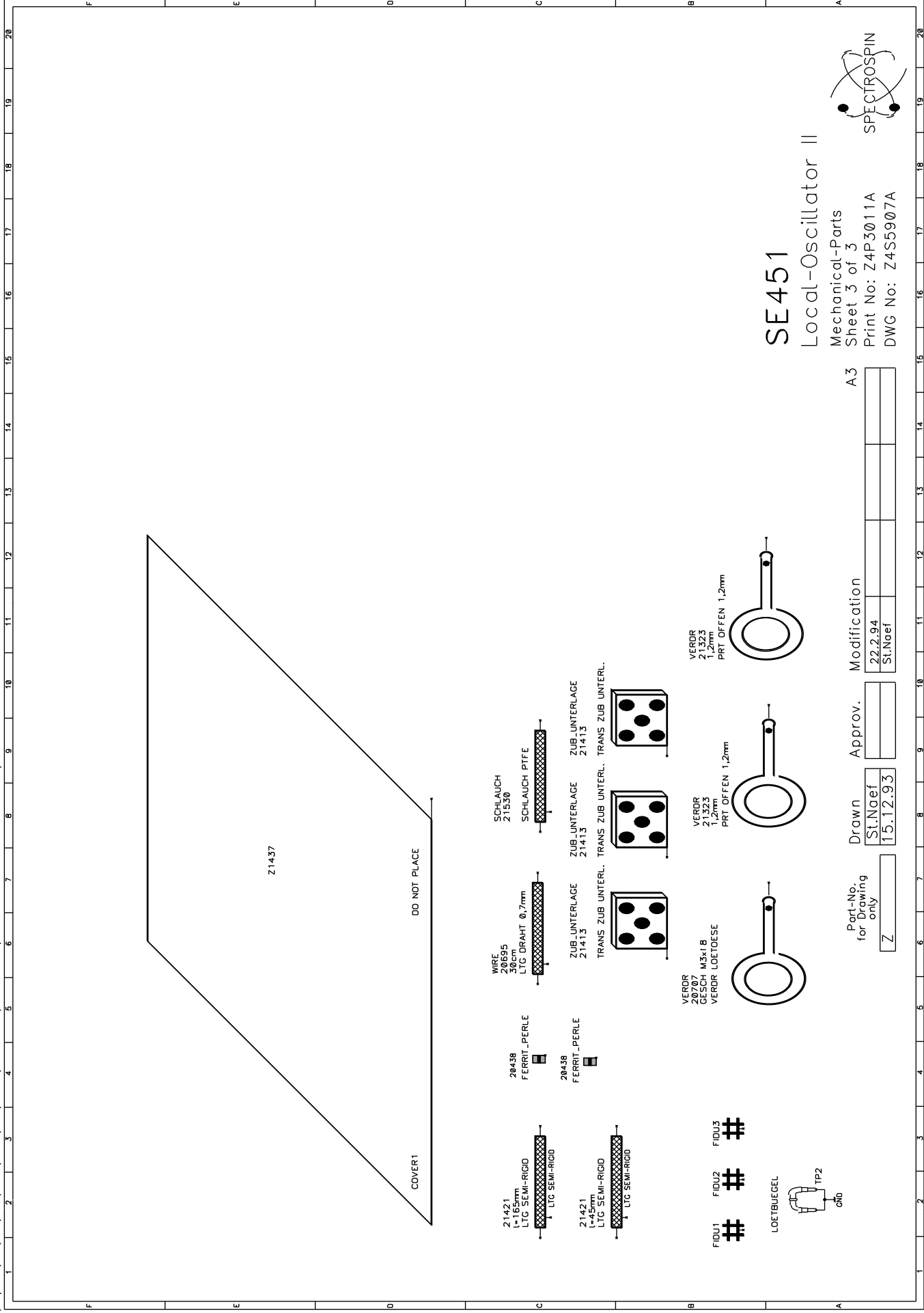

SE451

Local-Oscillator II

Mechanical-Parts
Sheet 3 of 3

Print No: Z4P3011A

DWG No: Z4S5907A

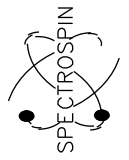

Part-No. for Drawing only	Drawn	Approv.	Modification	A3
Z	St.Naef 15.12.93		22.2.94 St.Naef	

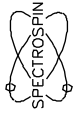
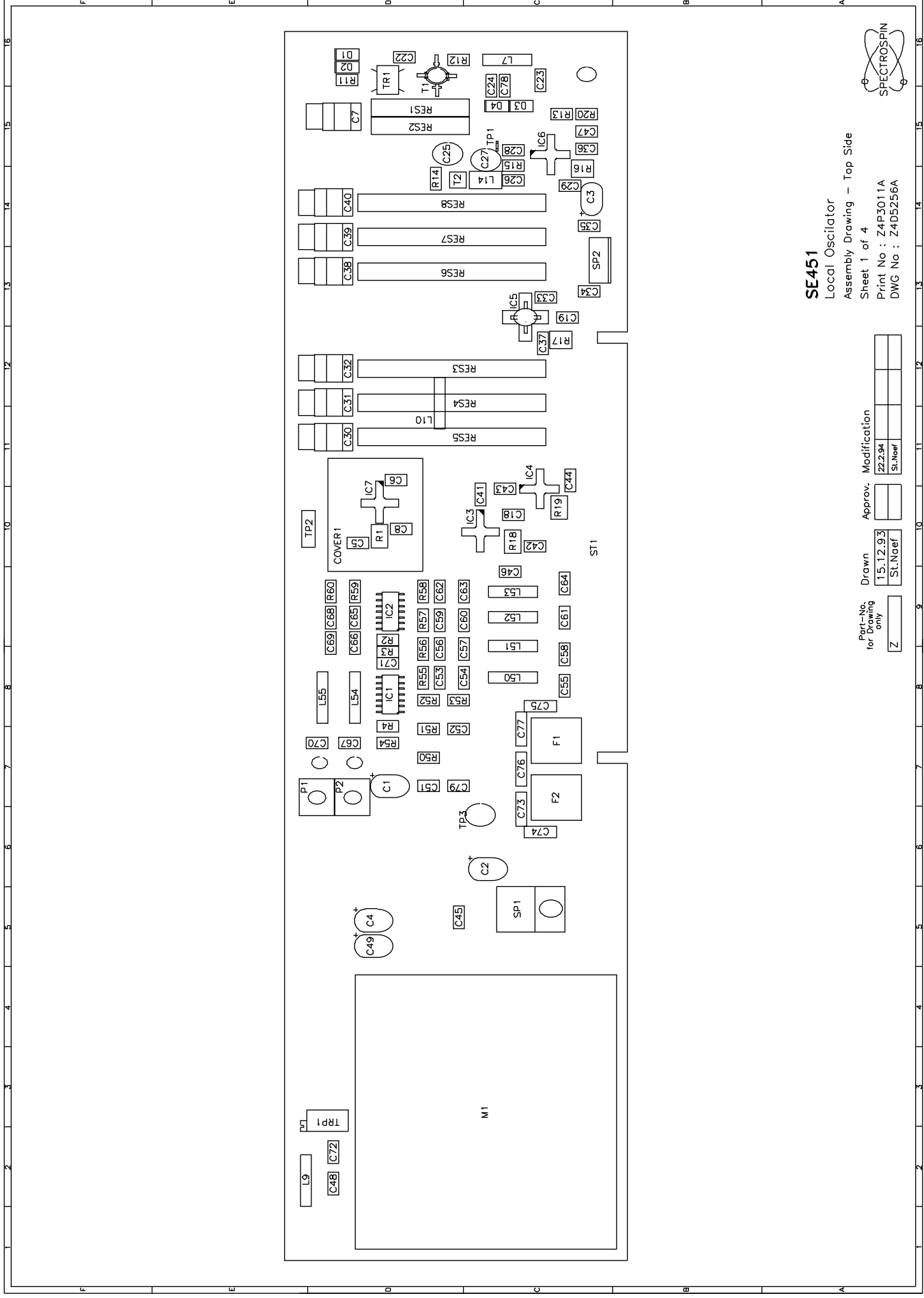

SE451

Local Oscillator
 Assembly Drawing - Top Side
 Sheet 1 of 4
 Print No : Z4P3011A
 DWG No : Z4D5256A

Part-No. for Drawing only	Drawn	Approv.	Modification
Z	15.12.93 St.Ngef		22.2.94 St.Ngef

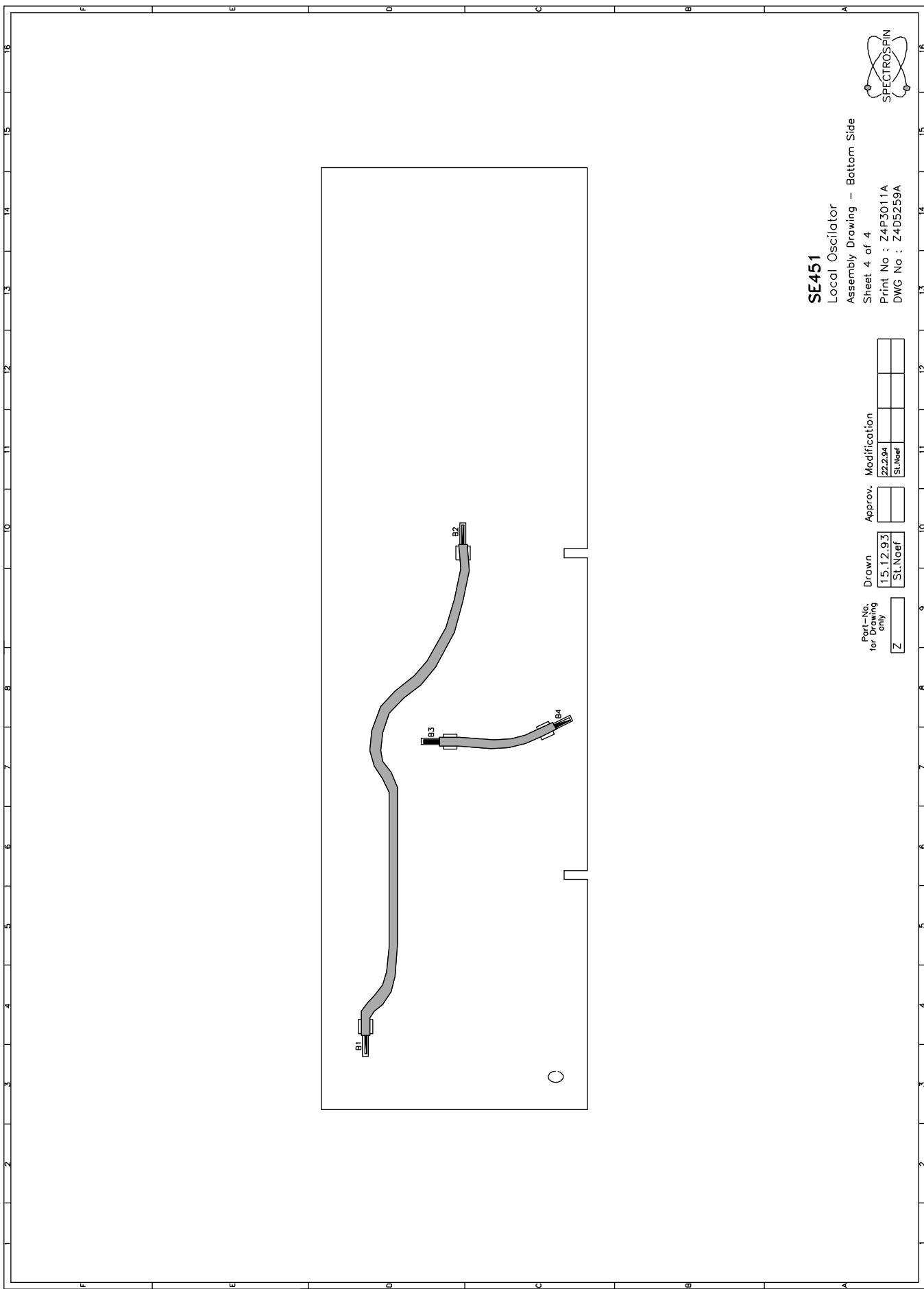

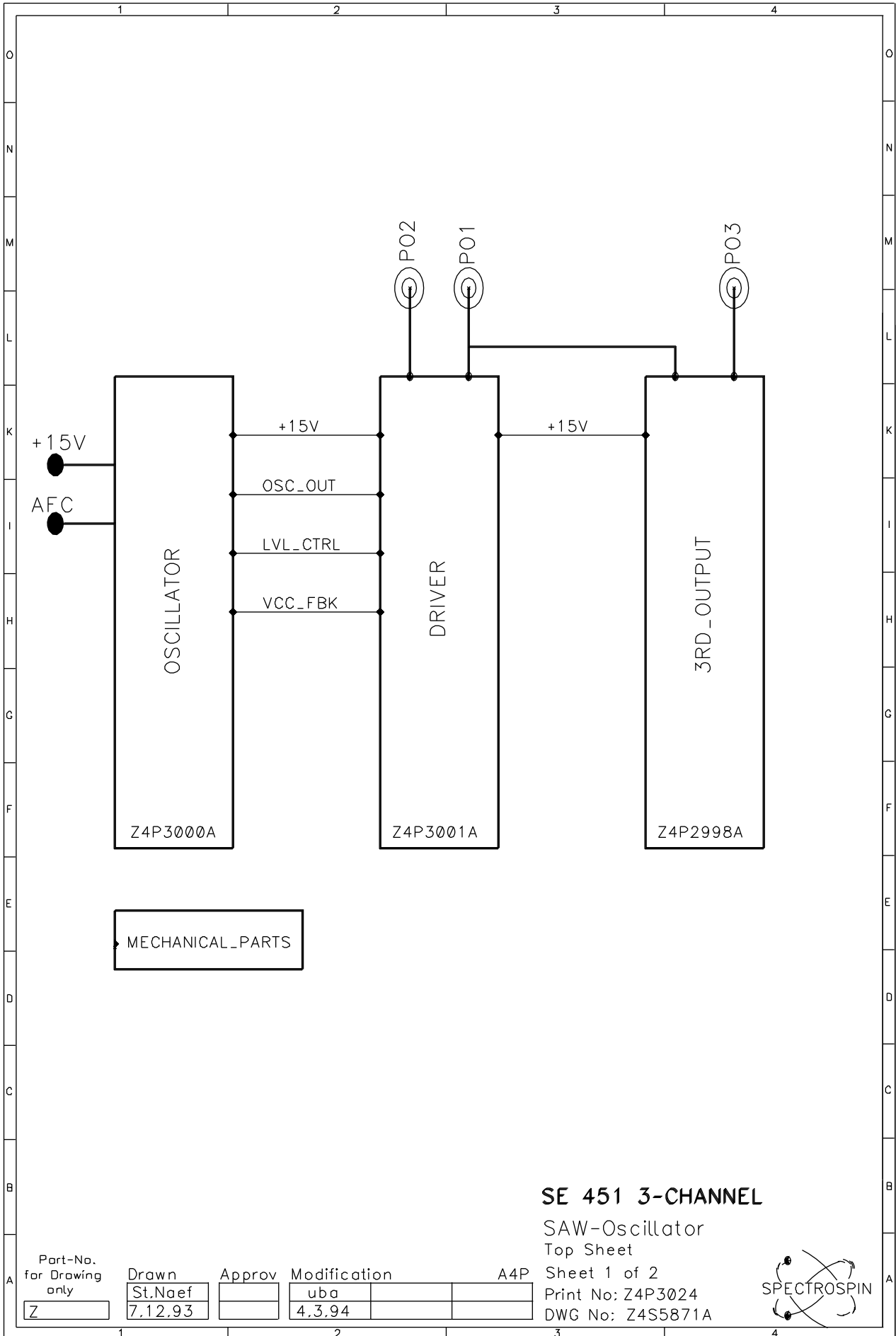

MECHANICAL_PARTS

SE 451 3-CHANNEL

SAW-Oscillator
Top Sheet

Sheet 1 of 2
Print No: Z4P3024
DWG No: Z4S5871A



Part-No. for Drawing only	Drawn	Approv	Modification	A4P
Z	St.Naef 7.12.93		uba 4.3.94	

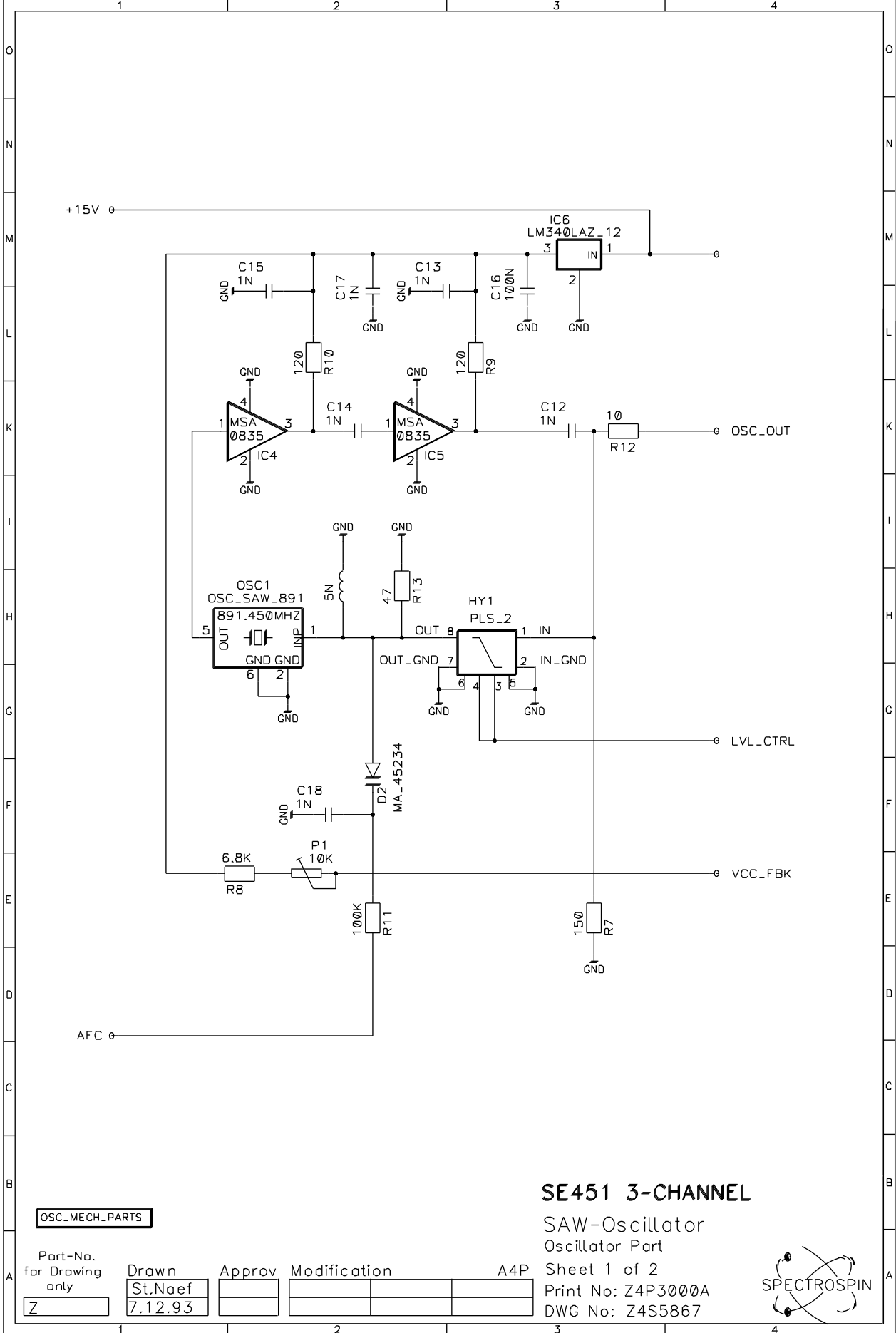

OSC_MECH_PARTS

SE451 3-CHANNEL

SAW-Oscillator
Oscillator Part

Sheet 1 of 2
Print No: Z4P3000A
DWG No: Z4S5867

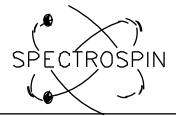

Part-No. for Drawing only	Drawn	Approv	Modification	A4P
Z	St.Naef 7.12.93			

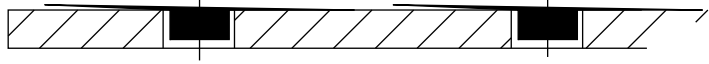

Koerper des MSA im Print versenken

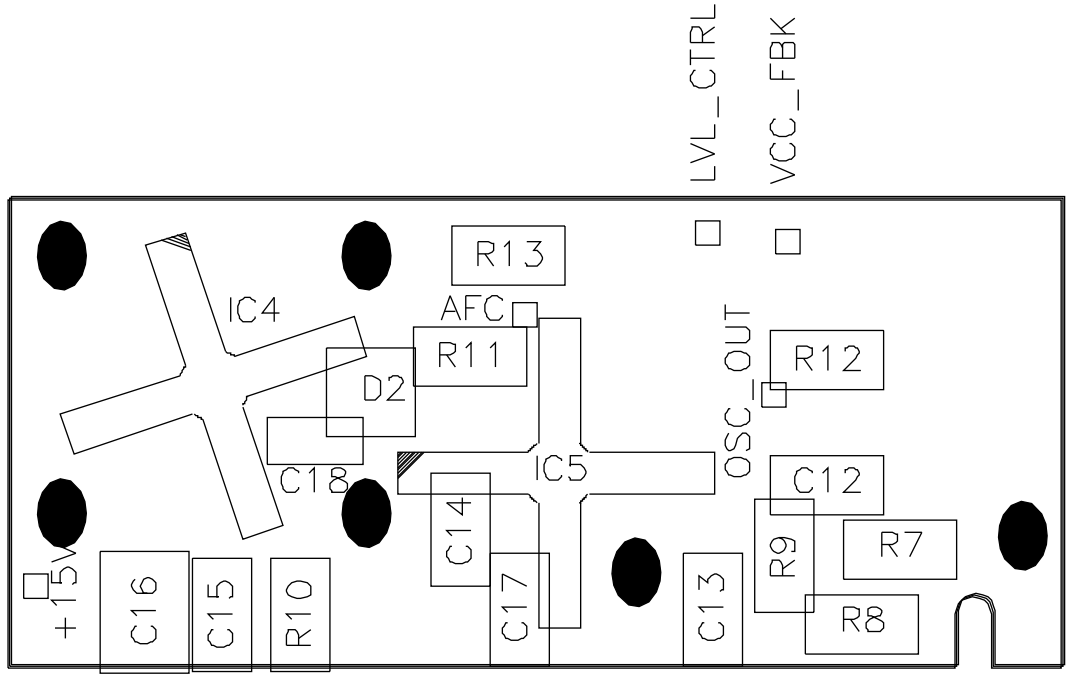

Top side

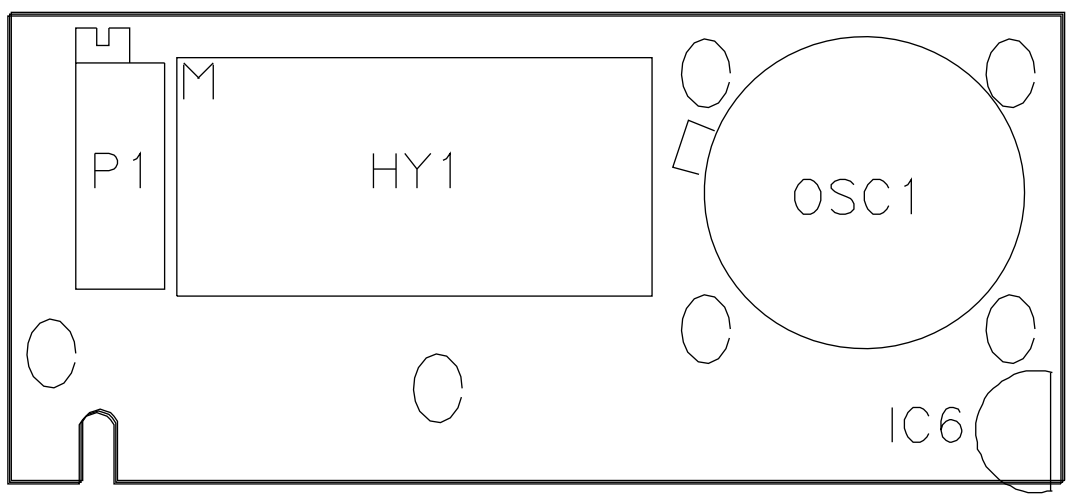

Bottom side

SE451 3-CHANNEL
Oscillator
Assembly Drawing

Part-No. for Drawing only	Drawn	Approv.	Modification		
Z	9.Dez.93 St.Naef		18.3.94 uba		

Print No : Z4P3000A
DWG No :

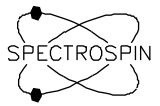

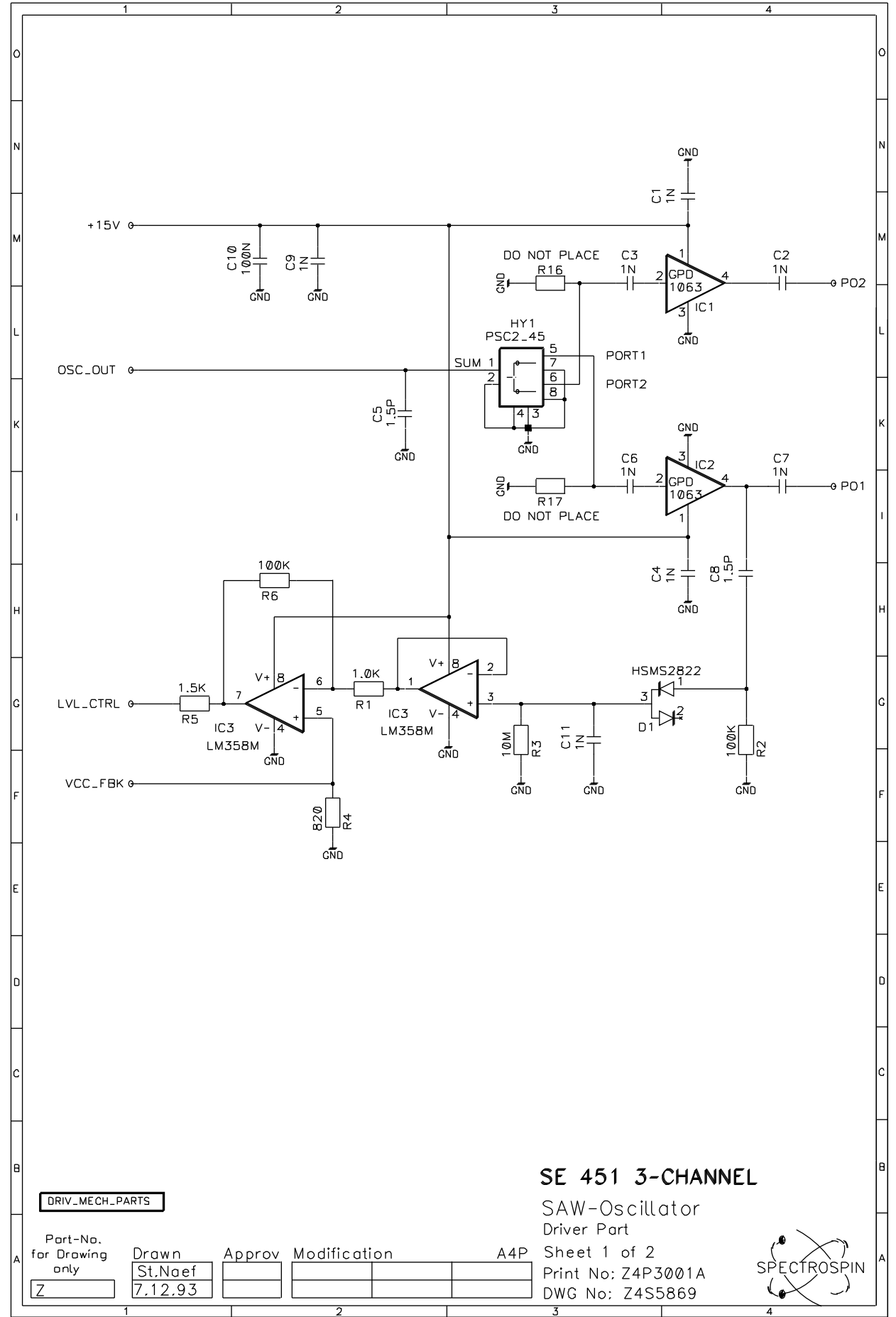

DRIV_MECH_PARTS

Part-No.
for Drawing
only

Z

Drawn
St.Naef
7.12.93

Approv

Modification

A4P

SE 451 3-CHANNEL

SAW-Oscillator
Driver Part

Sheet 1 of 2

Print No: Z4P3001A

DWG No: Z4S5869



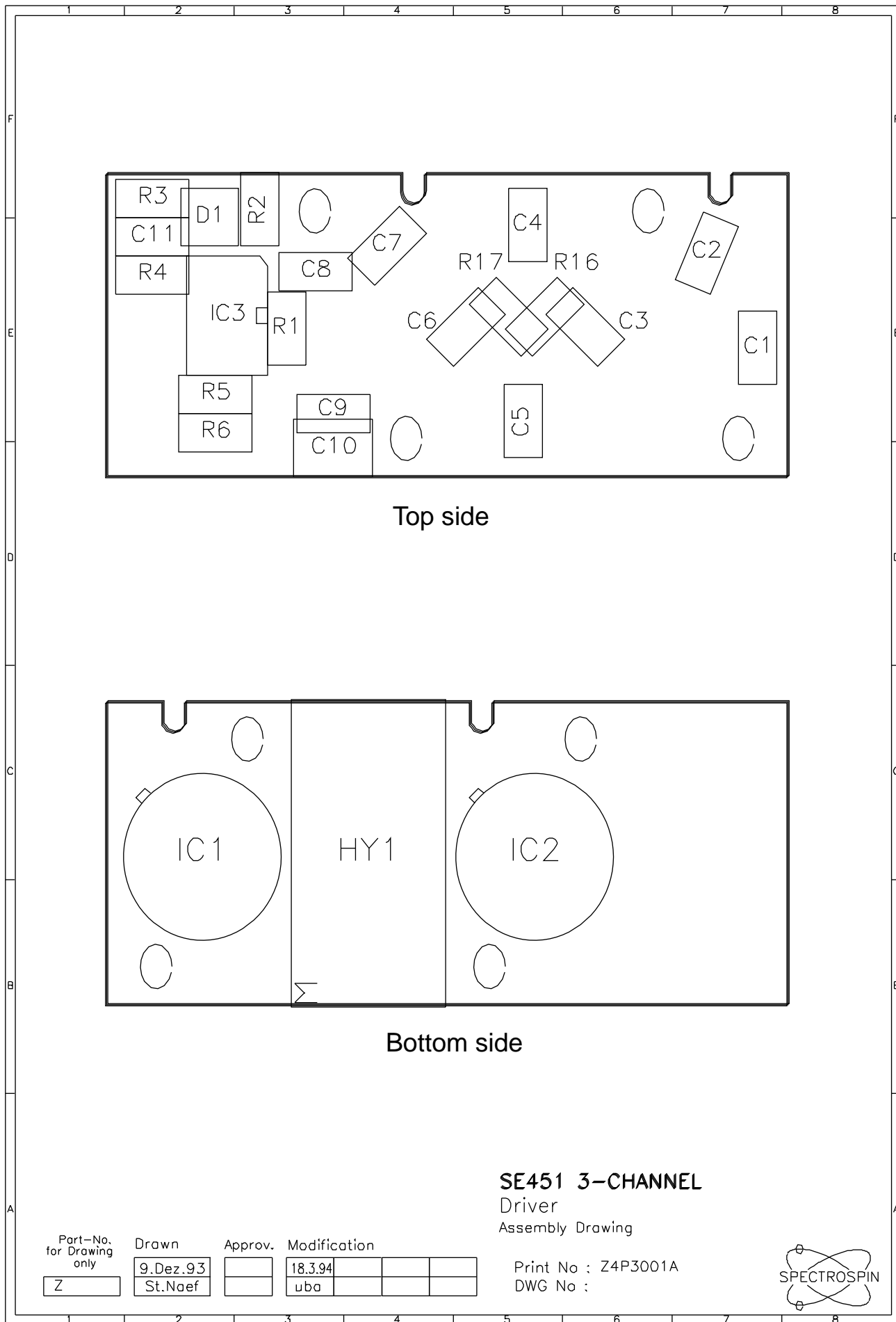

Top side

Bottom side

SE451 3-CHANNEL

Driver
 Assembly Drawing

Part-No. for Drawing only	Drawn	Approv.	Modification			
Z	9.Dez.93 St.Naef		18.3.94 uba			

Print No : Z4P3001A
 DWG No :

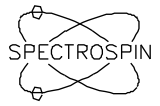

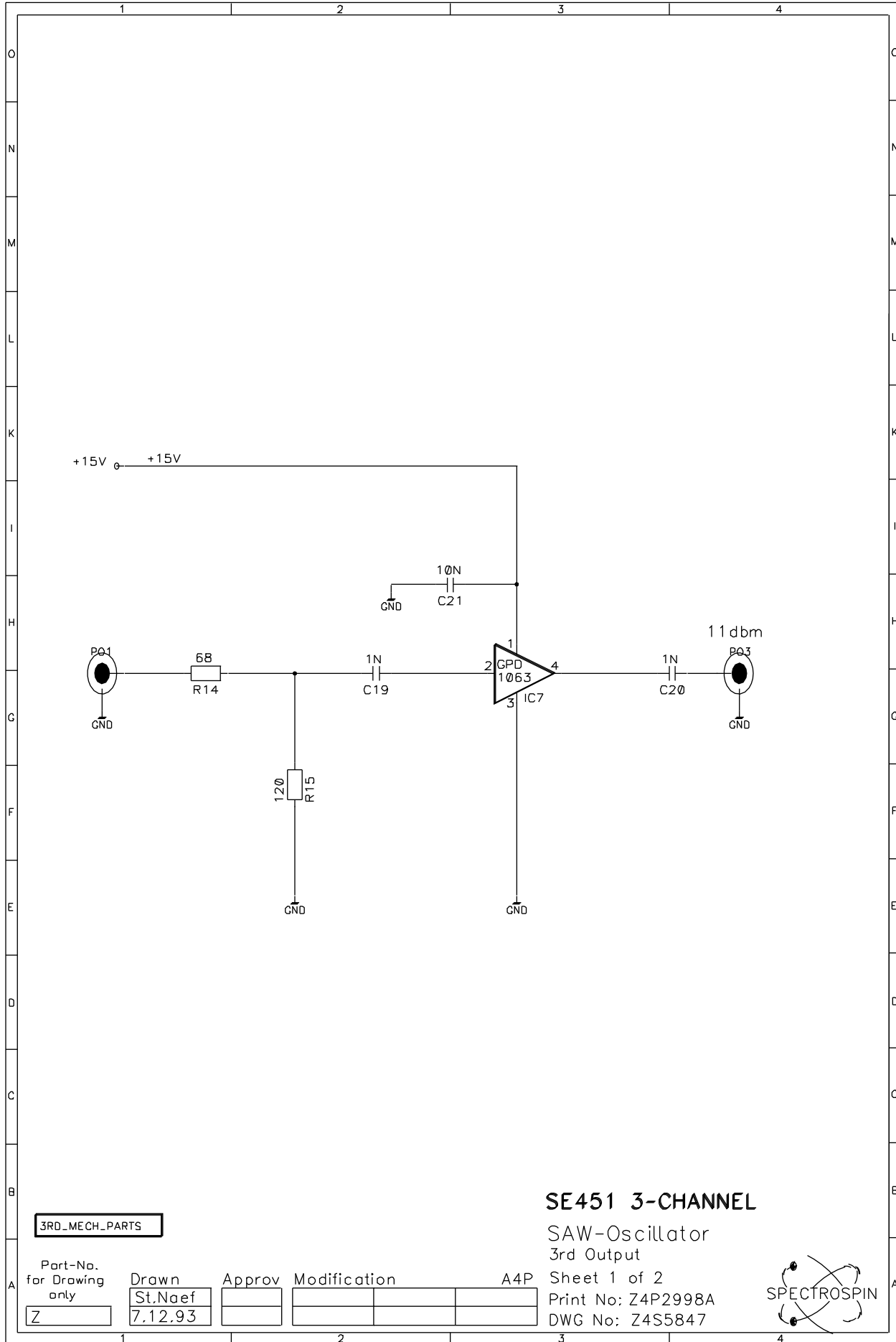

3RD_MECH_PARTS

SE451 3-CHANNEL

SAW-Oscillator
3rd Output

Part-No. for Drawing only	Drawn	Approv	Modification	A4P
Z	St.Naef 7.12.93			

Sheet 1 of 2
Print No: Z4P2998A
DWG No: Z4S5847

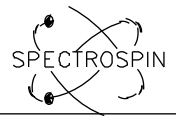

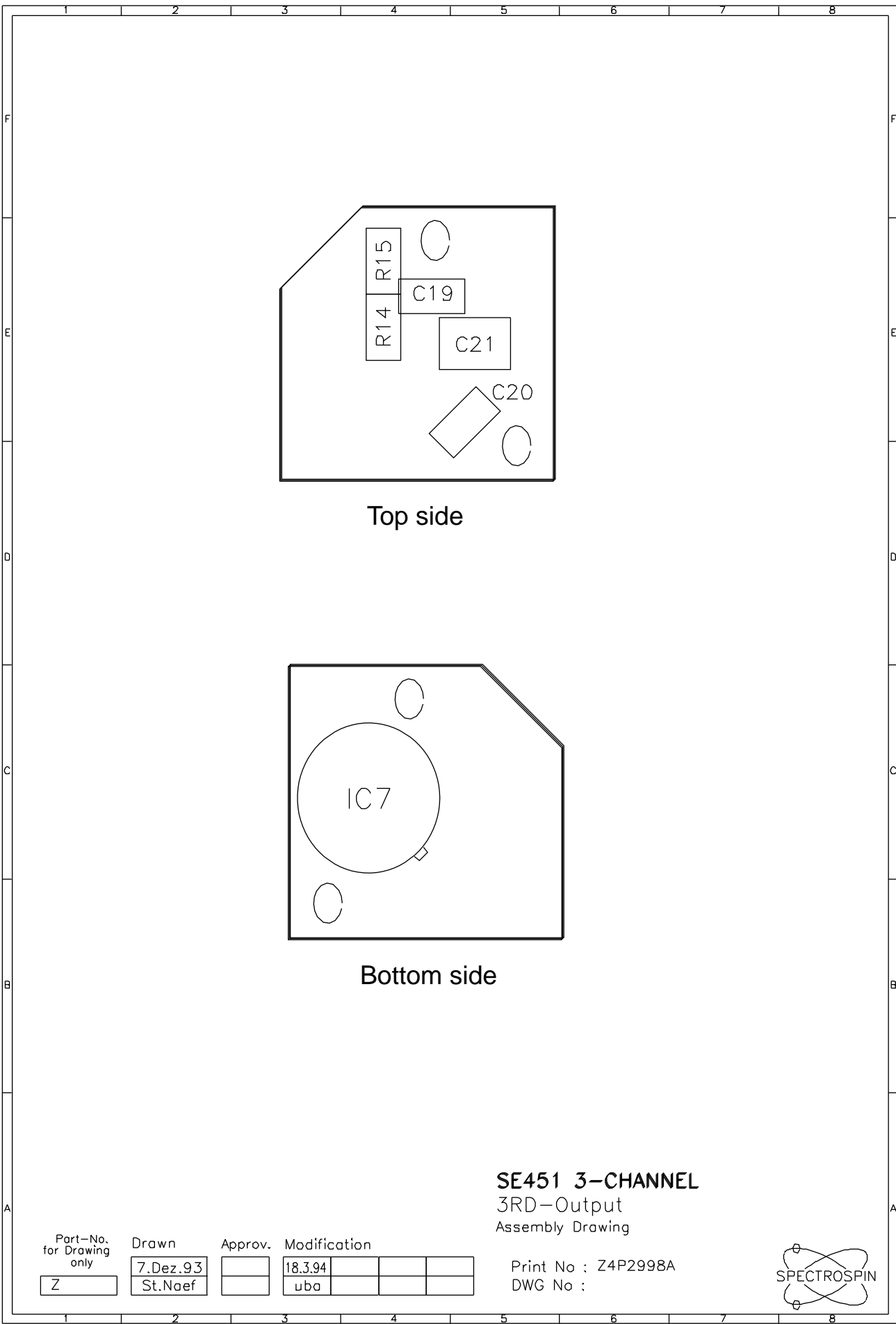

Top side

Bottom side

SE451 3-CHANNEL
 3RD-Output
 Assembly Drawing

Part-No.
for Drawing
only

Z

Drawn

7.Dez.93
St.Naef

Approv.

Modification

18.3.94			
uba			

Print No : Z4P2998A
 DWG No :



SE451_DECKEL
Z1925
Z4M40 12A
SE-451L-DECKEL

SE451_DECKEL
Z12604
Z4M7712
SE-451-DECKEL

SCHILD_PL_KLAR

SCHILD_SAW_OSCI

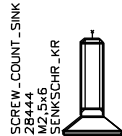

SCREW_COUNT_SINK
Z28444
M2,5x5
SENKSCHR_KR

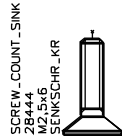

SCREW_COUNT_SINK
Z28444
M2,5x5
SENKSCHR_KR

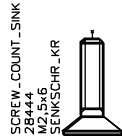

SCREW_COUNT_SINK
Z28444
M2,5x5
SENKSCHR_KR

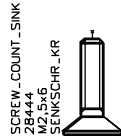

SCREW_COUNT_SINK
Z28444
M2,5x5
SENKSCHR_KR

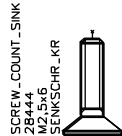

SCREW_COUNT_SINK
Z28444
M2,5x5
SENKSCHR_KR

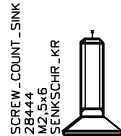

SCREW_COUNT_SINK
Z28444
M2,5x5
SENKSCHR_KR

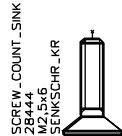

SCREW_COUNT_SINK
Z28444
M2,5x5
SENKSCHR_KR

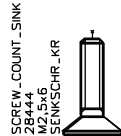

SCREW_COUNT_SINK
Z28444
M2,5x5
SENKSCHR_KR

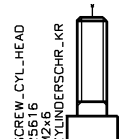

SCREW_CYL_HEAD
Z25616
M2x6
ZYLINDERSCHR_KR

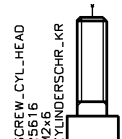

SCREW_CYL_HEAD
Z25616
M2x6
ZYLINDERSCHR_KR

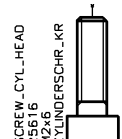

SCREW_CYL_HEAD
Z25616
M2x6
ZYLINDERSCHR_KR

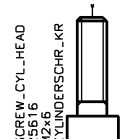

SCREW_CYL_HEAD
Z25616
M2x6
ZYLINDERSCHR_KR

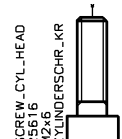

SCREW_CYL_HEAD
Z25616
M2x6
ZYLINDERSCHR_KR

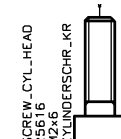

SCREW_CYL_HEAD
Z25616
M2x6
ZYLINDERSCHR_KR

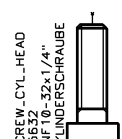

SCREW_CYL_HEAD
Z25632
UNF 10-32x1/4"
ZYLINDERSCHRAUBE

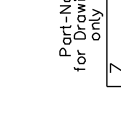

SCREW_CYL_HEAD
Z25632
UNF 10-32x1/4"
ZYLINDERSCHRAUBE



VFIBRE DURCHFUEHRUNG
Z11578
Ø93/Ø93P

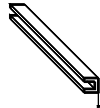

ST_KOAX_ADAPT
SMA-I-BU-BU
34SMA

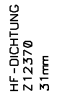

HF-DICHTUNG
Z12370
31mm

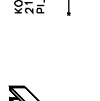

ST_KOAX_ADAPT
SMA-I-BU-BU
34SMA

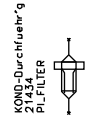

KOND-Durchführ'g
Z1434
PL-FILTER

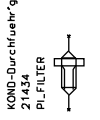

KOND-Durchführ'g
Z1434
PL-FILTER

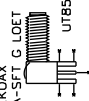

ST_KOAX_ADAPT
SMA-I-BU-BU
34SMA

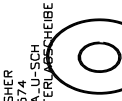

WASHER
Z11574
SCH
UNTERLAGSCHEIBE

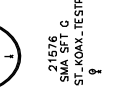

WASHER
Z11574
SCH
UNTERLAGSCHEIBE

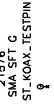

21576
SMA SFT G
SMA-KOAX-TESTPIN



20894
FERRIT_PERLE

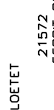

21572
FERRIT_PERLE



21576
SMA SFT G
SMA-KOAX-TESTPIN

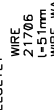

20894
FERRIT_PERLE



21572
FERRIT_PERLE

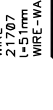

21576
SMA SFT G
SMA-KOAX-TESTPIN



20894
FERRIT_PERLE



21572
FERRIT_PERLE

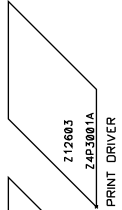
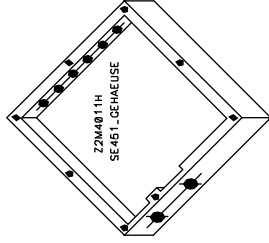
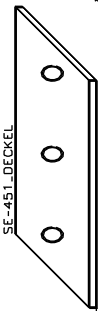
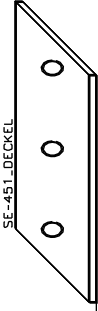

Z12603
Z4P3001A
PRINT DRIVER

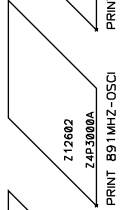

Z12602
Z4P3008A
PRINT B91MHZ-OSCI

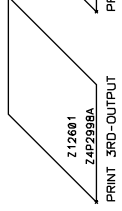

Z12601
Z4P2988A
PRINT 360-OUTPUT

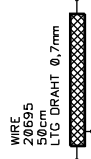

WIRE
Z1706
L=57mm
WIRE-WARP ROT
LTG DRAHT Ø,7mm

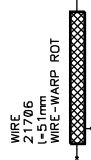

WIRE
Z1706
L=57mm
WIRE-WARP ROT

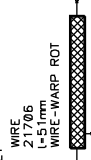

WIRE
Z1706
L=57mm
WIRE-WARP ROT

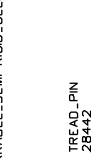

WIRE
Z1706
L=57mm
WIRE-WARP BLAU

Se451 3-CHANNEL SAW Oscillator

Mechanical-Parts
Sheet 2 of 2
Print No: Z4P3024
DWG No: Z4S5872A

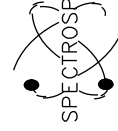

Part-No. for Drawing only	Z	Drawn	St.Noef	Modifcation	uBg	A3
					4.3.94	

1.SE451 3-CHANNEL	7
Figure 1: SE451-3CH frequency generation and block diagram	8
Figure 2: Function diagram SE451	9
2.Connectors and Signals	11
Figure 3: Burndy1: SE451-3CH control connector	11
Figure 4: Burndy2: 4 Phase Modulator Control Connector	13
Figure 5: RXC Control 25 Sub-D Connector Pin Assignment	14
Figure 6: ext. supply connector pin assignment	16
3.Motherboard Z4P2997	17
Figure 7: Block diagram of the LO-Switch on the SE451-3CH motherboard Z4P2997	17
4.PAL Equations	19
Figure 8: Location of the jumpers JU1 ... JU4	19
Figure 9: Pin Connections of the PAL on the motherboard of the SE451-3CH. 24	24
5.4Phase Modulator	25
Figure 10: Block Diagram of the 4Phase Modulator RF Board	25
Figure 11: Block Diagram of QPSK-Modulator.....	26
Figure 12: Phase states in normal operation mode of a QPSK-modulator.....	26
Figure 13: Control currents for 4 quadrant phase shift.....	28
6.Temperature Controller	29
7.BBIS for SE451-3CH	33
8.Technical Data	37
9.ECL Information	39
10.Y-Cable Z12621	41
Figure 14: DC-Wiring of SE451-3CH Y-cable.....	42
Figure 14: SE451-3CH Y-cable HF-wiring	43
11.Schematics Motherboard	45
Figure 15: Chassis wiring	46
Figure 16: LO-Switch	47
Figure 17: Control	48
Figure 15: Connectors.....	49
Figure 15: Quad phase shifter	50
Figure 16: BBIS.....	51
Figure 17: Mechanical parts.....	52
Figure 18: Assembly drawing high resolution	53
Figure 19: Assembly drawing solids.....	54
12.Schematics BBIS Board	55
Figure 18: BBIS Piggy-Back	57

Figure 18:	Assembly drawing BBIS.....	59
13.Schematics Temp. Contr.		61
Figure 19:	Temperature Controller	63
Figure 19:	Mechanical parts	65
Figure 20:	Assembly Temperatuer Controller	66
14.Schematics Receiver Board		67
Figure 20:	Assembly drawing Receiver Board	68
Figure 21:	Receiver Board	69
Figure 22:	Assembly drawing BB Option	70
Figure 23:	BB Option.....	71
Figure 24:	Mechanical parts RF Modul	72
Figure 25:	RF Modul	73
Figure 26:	Assembly drawing RF Modul top side	74
Figure 27:	Assembly drawing RF Modul bottom side	75
Figure 28:	Wiring RF Modul.....	76
Figure 29:	QD Modul.....	77
Figure 20:	Assembly drawing QD Modul bottom side	78
Figure 21:	Assembly drawing QD Modul top side	79
15.Schematics LO-Board II		81
Figure 30:	Local Oszillator Board II.	82
Figure 31:	Buffer	83
Figure 32:	LO Board II Mechanical Parts	84
Figure 33:	Assembly drawing LO Board top side	85
Figure 34:	Assembly drawing LO Board bottom side	86
Figure 35:	SAW Oszillator Block diagram	87
Figure 30:	Oszillator	88
Figure 31:	Assembly drawing Oszillator	89
Figure 32:	Driver	90
Figure 33:	Assembly drawing Driver.....	91
Figure 34:	3rd Output	92
Figure 35:	Assembly drawing 3rd Output	93
Figure 36:	SAW Oszillator Mechanical Parts.....	94

1.SE451 3-CHANNEL	7
Tabelle 1. Gain Table for 6dB Steps SE451-3CH	10
2.Connectors and Signals	11
Tabelle 2. Burndy1 signal description	12
Tabelle 3. SMA connectors on the front pannel of the SE451-3CH	14
Tabelle 4. BNC connectors on the front pannel of the SE451-3CH	15
Tabelle 5. Alternativ signal names used on the screen printing of the SE451-3CH motherboard 15	
3.Motherboard Z4P2997	17
4.PAL Equations.....	19
Tabelle 6. Jumper settings (factory configuration):	20
Tabelle 7. Jumper settings for replaced 2-CH units:	20
Tabelle 8. Description of the jumpers on the SE-451-3CH motherboard:	21
Tabelle 9. Input signals of the PAL, IC7	22
Tabelle 10. Output signals of the PAL, IC7	22
Tabelle 11. PAL equations of IC7, EP910PLCC	23
5.4Phase Modulator	25
6.Temperature Controller	29
7.BBIS for SE451-3CH.....	33
Tabelle 12. Example for a production page:	33
Tabelle 13. Example for a service page:	34
Tabelle 14. Example for a device block:	35
Tabelle 15. Example for an application block:	36
8.Technical Data	37
Tabelle 16. Gain Table for 6dB Steps SE451-3CH	38
9.ECL Information.....	39
Table 17: ECL Information for 3-Channel SE451	39
10.Y-Cable Z12621	41
11.Schematics Motherboard	45
12.Schematics BBIS Board.....	55
13.Schematics Temp. Contr.....	61
14.Schematics Receiver Board	67
15.Schematics LO-Board II	81

