

***BioSpec<sup>®</sup> Systems***

*(actively-shielded magnets)*

**Site Planning Information**

**Instructions and Comments  
for site preparation**

---

**BRUKER MEDICAL GMBH**

---

Copyright © by BRUKER MEDICAL GMBH  
All rights reserved. No part of this publication may be reproduced,  
stored in a retrieval system, or transmitted, in any form, or by any  
means without the prior consent of the publisher.  
Product names used are trademarks or registered trademarks of  
their respective holders.

This document was written by

©; BRUKER MEDICAL GMBH

Printed in Federal Republic  
of Germany 04.12.2000

Document No: T3N -1562

Document Part No: T8428

## Table of Contents

Page

<b>A. Preamble to this Site Planning Guide .....</b>	<b>5</b>
<b>B. Installation Examples .....</b>	<b>6</b>
B.1. Installation Example compact, <i>BioSpec</i> ® B-C 70/30USR.....	6
B.2. Installation Example, <i>BioSpec</i> ® B-C 70/30USR.....	7
B.3. Installation Example compact, <i>BioSpec</i> ® M-C 94/20AS.....	8
<b>C. Requirements and Conditions Concerning the System Installation.....</b>	<b>9</b>
C.1. The Building .....	9
C.1.a. Installation of the System.....	9
C.1.b. Security Zone of the Magnet.....	9
C.1.c. Climatological Requirements on the Air-Conditioning System .....	9
C.1.d. Electrical Installation, Requirements and Conditions .....	10
C.1.e. Instructions for the Security and Cleaning Personal .....	12
C.1.f. Instructions for the Responsible Fire Brigade .....	12
C.2. Requirements for the Magnet Room.....	13
C.2.a. Air Ventilation.....	13
C.2.b. Dimensions and Floor Loading .....	13
C.2.c. Quench Tube (or Cylinder) .....	14
C.2.d. Opening for Magnet Transport.....	15
C.2.e. Cable trays between the Magnet and Cabinets.....	15
C.2.f. Light Fixtures .....	16
C.2.g. Acoustic Noise and Structure-Borne Sound Decoupling.....	16
C.2.h. Building Vibrations and Their Propagation .....	16
C.2.i. Anesthesia Agents (Medical Gases) .....	17
C.2.j. Gaseous Helium Supply System 4.6 (> 99.996 volume %).....	17
C.2.k. RF-Shielding (Faraday Cage).....	18
C.3. Requirements for the Technical Room .....	18
C.3.a. Entrance Doors, Floor Strength.....	18
C.3.b. Acoustic Noise .....	18
C.3.c. Ventilation Technique in the Technical Room .....	18
C.3.d. Cold Water Supply for Cryo-Refrigerator.....	18
C.3.e. Drawings of Components in the Technical Room .....	19
C.3.f. Optional Components: Heat Exchanger for Cryo-Refrigerator.....	20
C.3.g. Cooling Water Connections for the Heat Exchanger: B-ER 090.....	21
C.3.h. Cooling Water Requirements for the Heat Exchanger: B-ER 090.....	21
C.4. Requirements for the Operating Room .....	22
C.4.a. Lighting and Window Surfaces .....	22
C.4.b. Air-Ventilation Technique.....	22
C.4.c. Cable Terrace for System Wiring .....	22
C.4.d. Telephone / Internet / Intranet .....	22
C.5. Storage Room for Cryogen Gases .....	22
C.6. Route of Transport for Cryogen Gases.....	23
C.7. Emergency Room, Emergency Plan.....	23

## Table of Contents

Page

<b>D. Planning Data of the Electronics Components .....</b>	<b>24</b>
D.1 Magnet Room.....	24
D.2 Operating Room.....	24
<b>D. Planning Data of the Electronics Components .....</b>	<b>25</b>
D.3 Technical Room "A" .....	25
<b>D. Planning Data of the Electronics Components .....</b>	<b>26</b>
D.3 Technical Room "B" .....	26
<b>E. Specifications of Various Magnet Types .....</b>	<b>27</b>
E.1.a. Side/Front-View of BioSpec® B-C 47/40USR.....	28
E.1.b. Stray-Field: B-C 47/40USR (Actively Shielded).....	29
E.2.a. Side/Front-View of BioSpec® M-C 70/20AS.....	30
E.2.b. Stray-Field: M-C 70/20AS (Actively Shielded).....	31
E.3.a. Side/Front-View of BioSpec® B-C 70/30USR.....	32
E.3.b. Stray-Field: B-C 70/30USR (Actively Shielded).....	33
E.4.a. Side/Front-View of BioSpec® M-C 94/20AS.....	34
E.4.b. Stray-Field: M-C 94/20AS (Actively Shielded).....	35
<b>F. Important Instructions for System Installation.....</b>	<b>36</b>
F.1. Installation.....	36
F.2. Passing of Risk .....	36
F.3. Prerequisites for the Installation .....	36
F.4. Transportation of the Magnet to Installation Site.....	37
F.4.a. General Handling and Lifting Procedures.....	37
F.4.b. Moving .....	37
F.4.c. Lifting .....	37
F.4.d. Crane Operation .....	37
F.4.e. Fork Lift Operation .....	37
<b>G. Key Points for a BioSpec® System with B-C 70/30 USR Magnet.....</b>	<b>38</b>
Site Preparation.....	38
Seismic Vibrations, Magnet Protection .....	38
Exhaust System of the Magnet (Quench tube or cylinder):.....	38
The Security Zone of the Magnet:.....	38
Emergency Room, Emergency Plan:.....	38
Supply the Magnet with Cryogen Gases:.....	38

## **A. *Preamble to this Site Planning Guide***

The quality of the site preparation and installation of an MR system will have a strong influence on the future success of the work. Selecting the optimal arrangement within existing department structures and performing all building alterations correctly, reliably and in an aesthetically pleasing fashion requires a high degree of cooperation between experts from several different fields and ideal project management .

The information and instructions in this brochure reflect the present state of development of the system. All data and requests associated with the system installation are marked as „requirements“.

BRUKER supplies this information to the best of his knowledge and belief, based upon the experience of projects already completed.

For the accuracy of the information regarding construction regulations, bills, internal instructions and directions of the institute and /or operation BRUKER's representative assumes responsibility.

## B. Installation Examples

### B.1. Installation Example compact, BioSpec® B-C 70/30USR.

(BioSpec® System with a actively-shielded magnet)

Floor layout (required area: approx. 51 m<sup>2</sup>)

Scale: 1 : 75

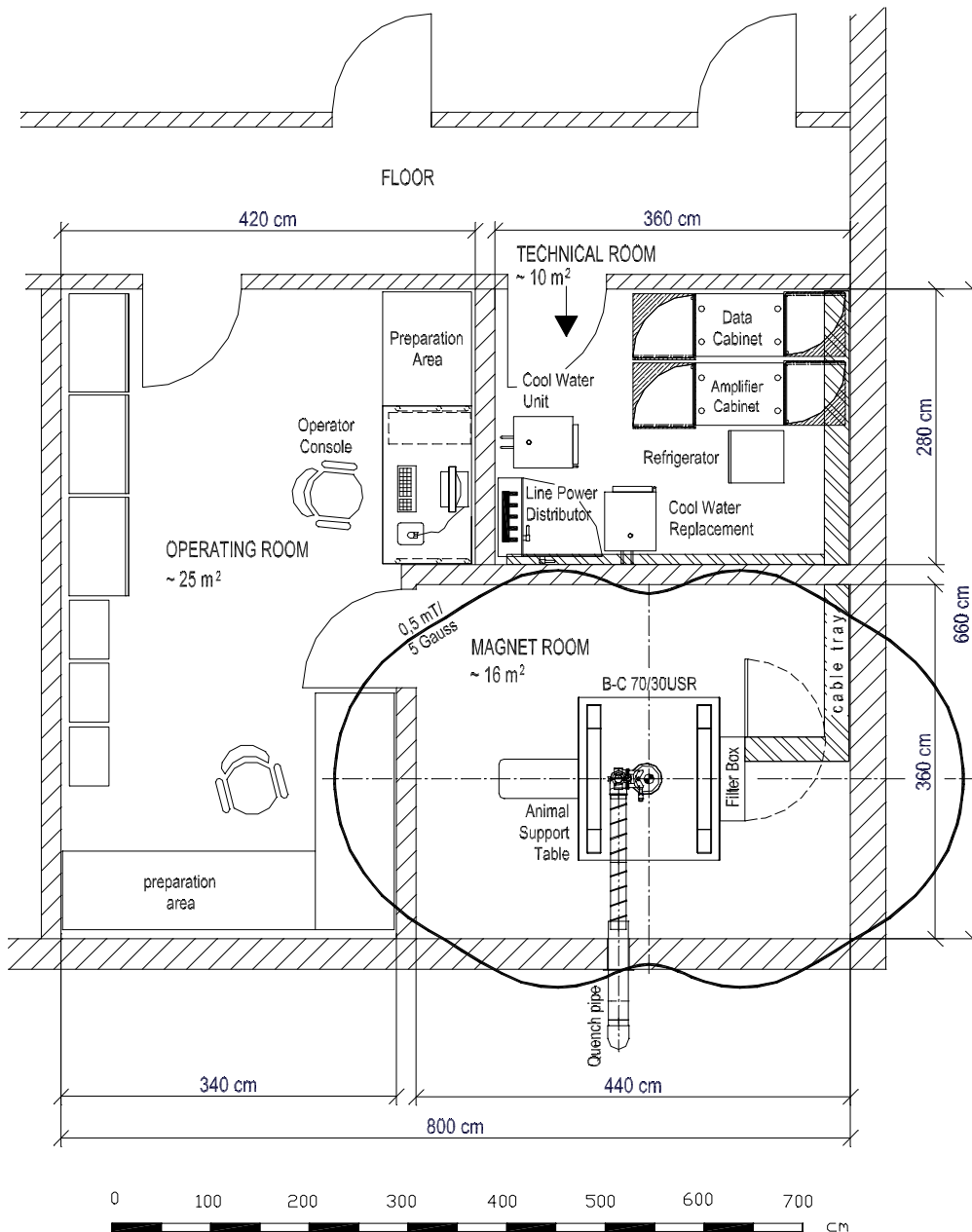

**B.2. Installation Example, BioSpec® B-C 70/30USR.**

(BioSpec® System with a actively-shielded magnet and all options)

**Floor layout** (required area: approx. 60 m<sup>2</sup>)

**Scale: 1 : 75**

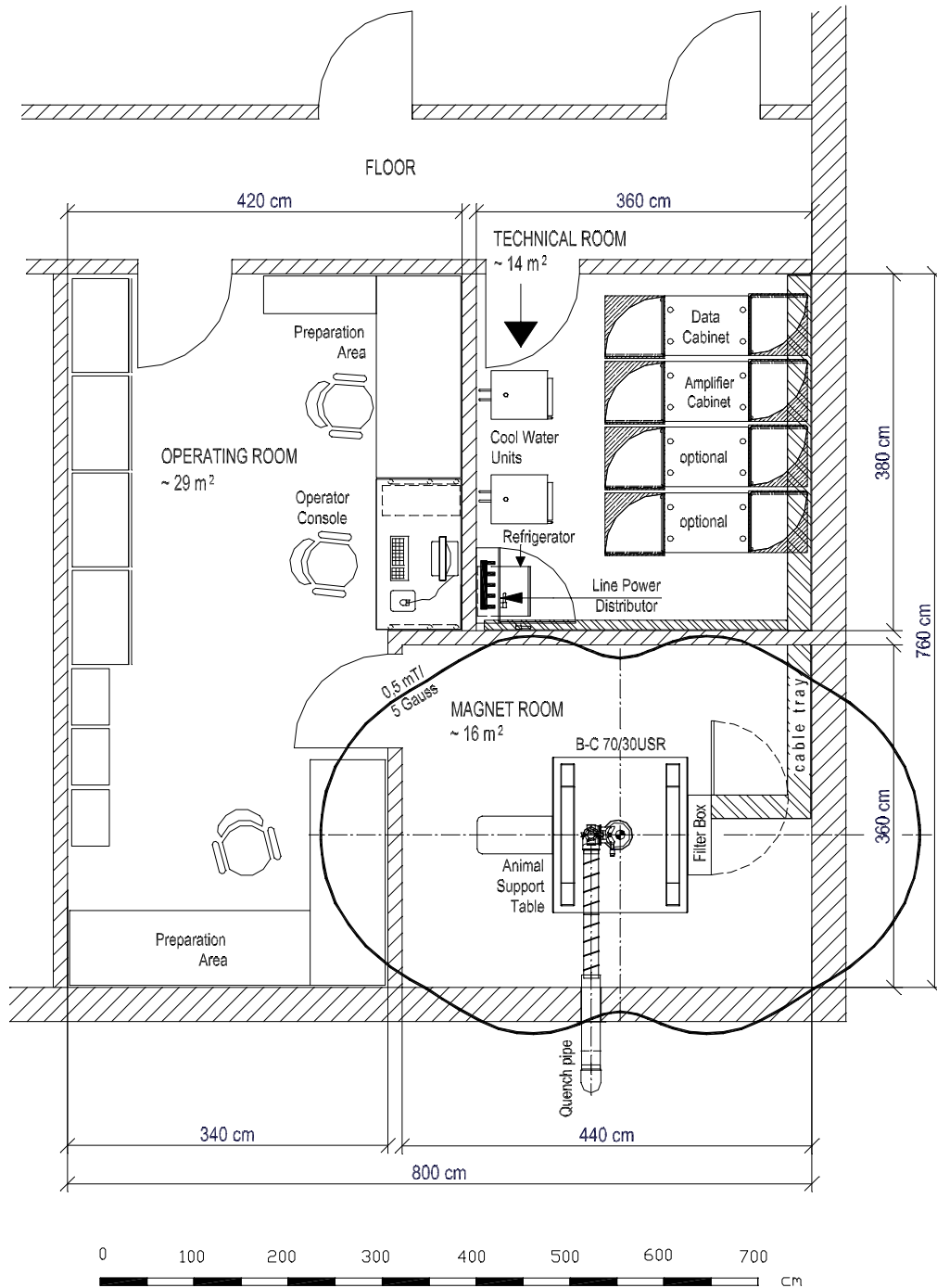

**B.3. Installation Example compact, BioSpec® M-C 94/20AS.**

*(BioSpec® System with a actively-shielded magnet)*

**Floor layout** (required area: approx. 47 m<sup>2</sup>)

**Scale: 1 : 75**

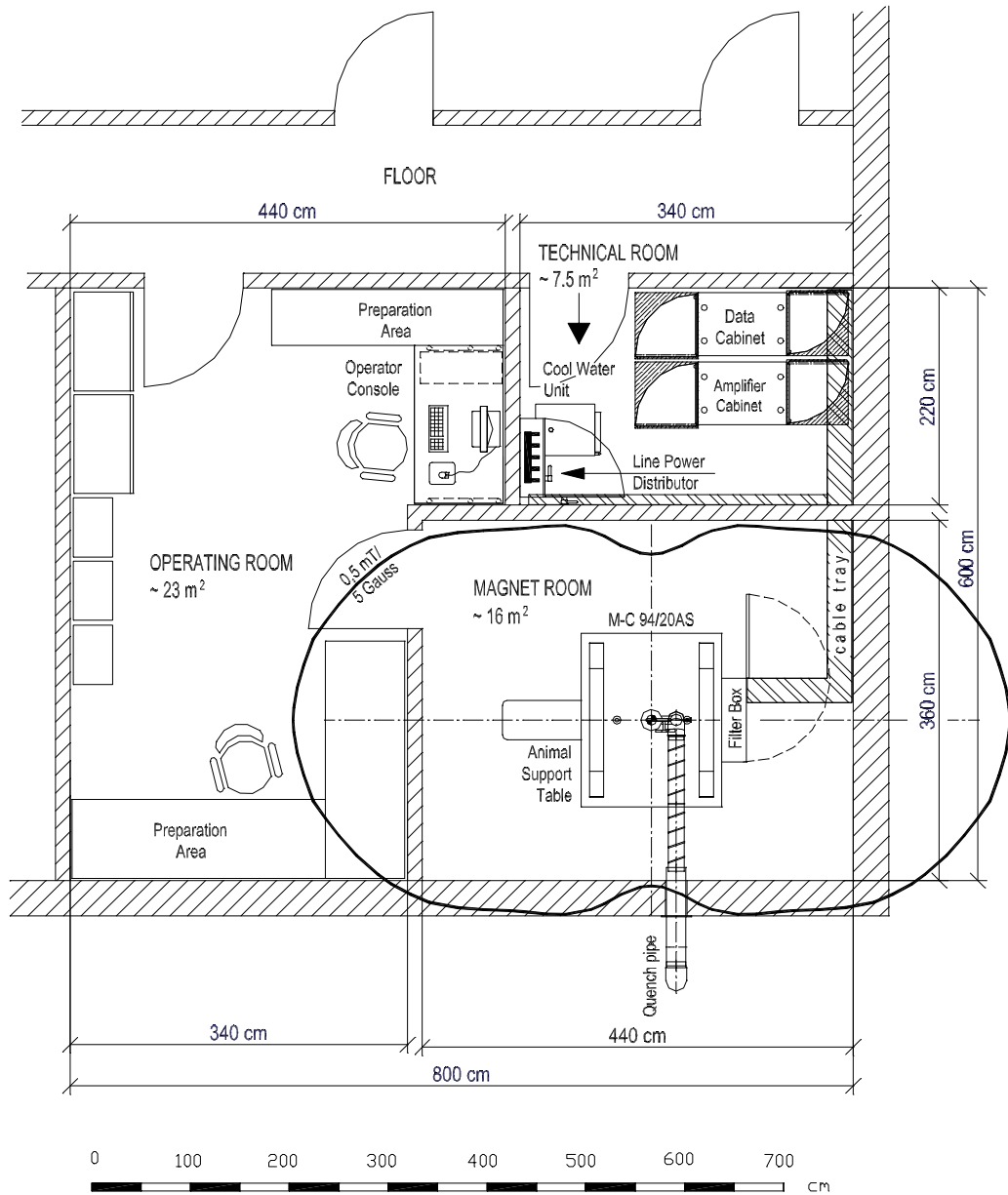



## C. Requirements and Conditions Concerning the System Installation

### C.1. The Building

**It is the responsibility of the customer to ensure that the route intended for the transport of the system, and more importantly the actual installation site, provide sufficient clear passage and weight-handling capability as will be required during the delivery of the system.** This applies for the magnet in the magnet area and for the components as well. The customer is responsible for the analysis and confirmation of the weight-handling capacity.

The transport routes must be sufficiently strong and wide for the transport and installation of a mobile crane (if required).

#### C.1.a. Installation of the System

**(It is the responsibility of the customer to create and close the openings required for placing of the system if not otherwise agreed upon beforehand).**

For placing of the magnet inside the magnet area an opening, either in the exterior wall or the roof of the building, is usually required. Occasionally a platform in front of the wall opening is necessary to bring the magnet to its final location. The loading capacity of the platform must be verified and confirmed by a structural engineer. The magnet will be transported on air pads or skates. The surface of the transport route must be even and should be at the same level as the floor of the magnet area. Irregularities of the surface cannot be present, even within the range of a few millimeters.

#### C.1.b. Security Zone of the Magnet

**No ferro-magnetic objects are allowed within the 0.5 mT stray-field, and the access of individuals with heart pacemakers must be restricted.**

Objects such as ball-point pens, scissors, screw-drivers, keys and even coins can be dangerous for personnel as such objects will be attracted by the magnet and will fly through the room like a projectile.

**Therefore a metal detector must be installed at all entrances to the magnet room.**

#### C.1.c. Climatological Requirements on the Air-Conditioning System

(Standard Configuration without any Options)

Temperature:	22° C ± 2° C
Relative humidity:	40-70 % (without condensation)
The total heat output in the	
- Technical Room "A" (with BRUKER USR magnet):	approx. 15 kW (max. approx. 18 kW)
- Technical Room "B" (with MAGNEX AS magnet):	approx. 5 kW (max. approx. 8 kW)
- Magnet Room:	approx. 0.1 kW
- Operating Room:	approx. 0.5 kW

**C.1.d. Electrical Installation, Requirements and Conditions**

**Power requirements** (standard configuration without options)

The AC power mode based upon TN-S, in accordance to DIN 57100 part 300, will be installed (Separate Neutral and Protective Grounding in the Entire Network). Other types of electrical supplies must be approved and confirmed by BRUKER.

Voltage:	400/230 V +5/-10 %
Current, frequency:	3 phase current, alternating current, 50-60 Hz
Connected loads:	approx. 20 kVA (with BRUKER USR magnet)
Consumption:	approx. 15.5 kW (with BRUKER USR magnet)
Connected loads:	approx. 7.5 kVA (with MAGNEX AS magnet)
Consumption:	approx. 5.5 kW (with MAGNEX AS magnet)

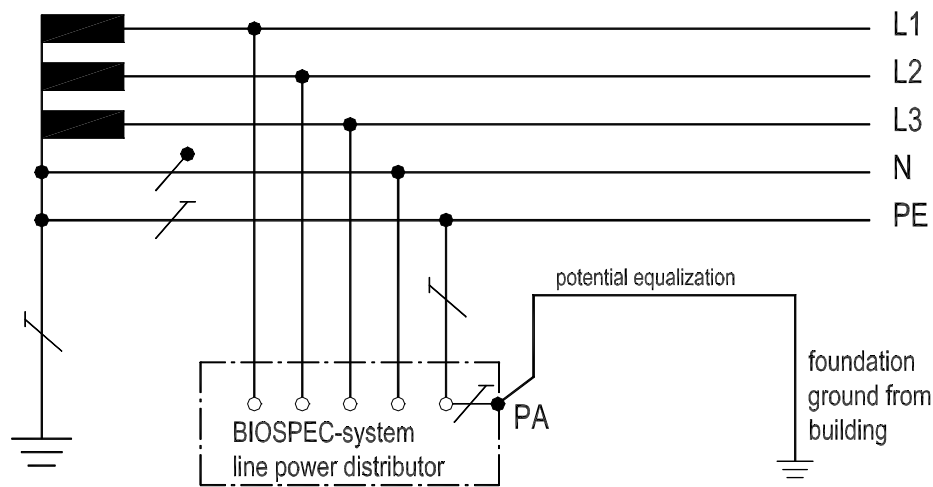

**Fig. C.1a: Line Power Connection Scheme for BioSpec® System**

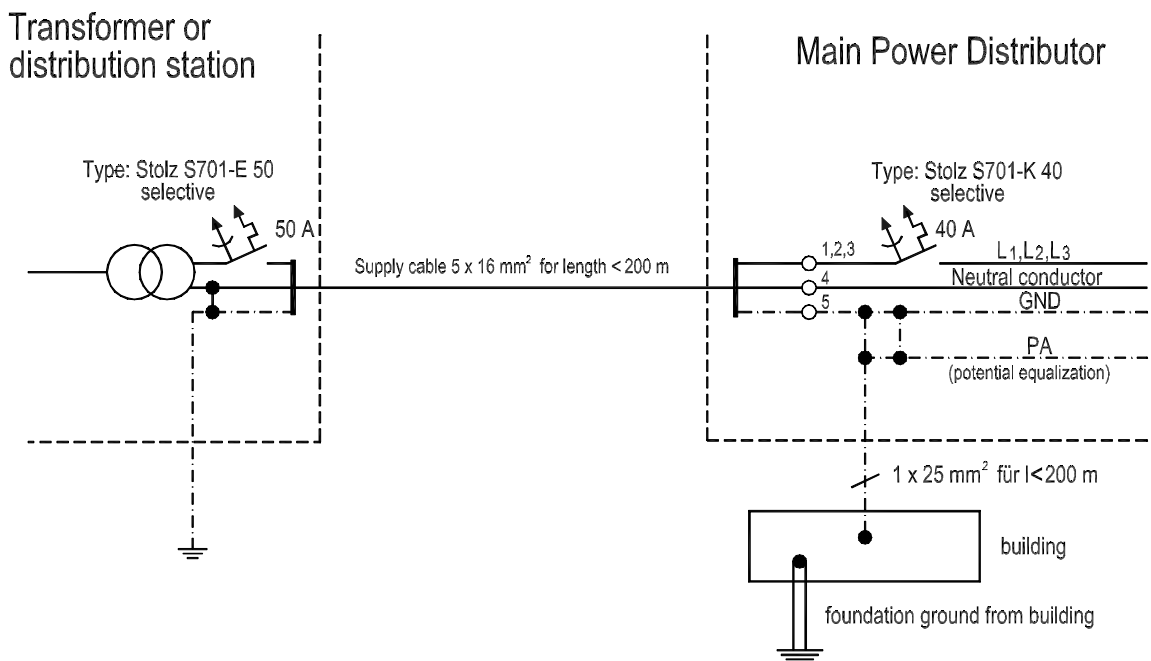

**Fig. C.1b: Electrical Supply to a BioSpec® System with BRUKER USR-Magnet**

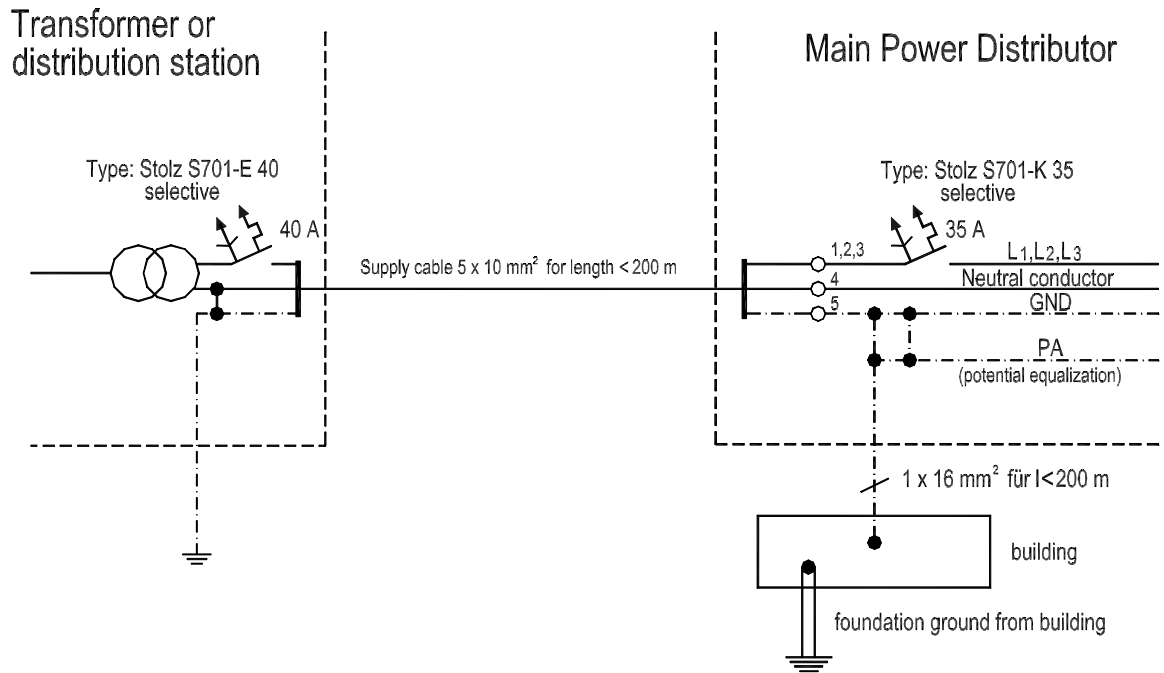

**Fig. C.1b: Electrical Supply to a *BioSpec*® System with Magnex AS-Magnet**

### Electrical Supply Lines

The customer is responsible for providing and installing all necessary electrical supply lines to the electrical distributor. The customer is also responsible for providing the connections to the transformer station and the electrical distributor.

#### **Supply lines for a *BioSpec*® System with BRUKER USR - Magnet:**

- **Main power supply line:** **5 x 16 mm<sup>2</sup> for length < 200 m**  
The voltage loss at the supply lines should be less than 3 % ( $U_v < 3\%$ ).  
The fuse value required for connecting the supply line ( e.g. building AC power distribution or transformer station ) must be in the range of 50 A .
- **Potential equalization line:** **1 x 25 mm<sup>2</sup> for length < 200 m.**  
To be connected to central building ground bar.

#### **Supply lines for a *BioSpec*® System with MAGNEX AS - Magnet:**

- **Main power supply line:** **5 x 10 mm<sup>2</sup> for length < 200 m**  
The voltage loss at the supply lines should be less than 3 % ( $U_v < 3\%$ )..  
The fuse value required for connecting the supply line ( e.g. building AC power distribution or transformer station ) must be in the range of 40 A .
- **Potential equalization line:** **1 x 16 mm<sup>2</sup> for length < 200 m.**  
To be connected to central building ground bar.

### Grounding

The grounding of the *BioSpec*® system, measured from the central grounding point of the system's electrical distribution box in relation to a control grounding outside the building, must not be greater than 5 Ohm. We recommend installing a separate grounding wire from the building ground to the grounding point at the system electrical distributor.

### **Potential compensation**

The BioSpec® system must be incorporated into the potential compensation of the installation site.

### **Electrical wiring and main connection sockets**

**The customer is responsible for the supply and installation of all necessary electrical supply lines and sockets inside the operation and magnet room.**

For the operation of the BioSpec® System three alternating current sockets 10 A each are necessary.

Two alternating current sockets (10 A) will be required in the direct vicinity of the operating console for supplying the computer components while the third will be required in the vicinity of the magnet for supplying the emergency quench device. If the first two sockets can be mounted at any height in the vicinity of the operating console, the third one must be placed in the main access area to the magnet at a height of approx. 140 cm above the ground and marked or secured against accidental removal.

Alternating current socket-type: Schuko-Connector 230 V / 10 A

### **Cable trays**

Supply and installation of cable trays to handle the system wiring are provided by the customer. The cable trays will be defined by BRUKER with regard to the local situation and according to the system requirements! The cables must be capable of being accommodated in a vertical orientation. At all curves or bends, the cables must be free from pinching or binding. Possible variants are:

a) Pedestal, b) Balustrade, c) Under the floor, d) Under the ceiling

## **C.1.e. Instructions for the Security and Cleaning Personal**

Security and cleaning personnel must be instructed not to enter the magnet room without the supervision of the operating personnel.

Example: If a vacuum cleaner or some other object is attracted to the magnet, simple removal is not permitted. If a person is pressed by any object to the magnet and cannot be released, the magnet must be discharged by pressing the emergency discharge button. Instructions can be found in the „Emergency Instructions“ pamphlet.

## **C.1.f. Instructions for the Responsible Fire Brigade**

It is recommended to organize a visit on site with the local fire brigade to discuss conduct during a fire.

**Only non-magnetic** fire extinguishers equipped with CO<sub>2</sub> must be used in the magnet room. Ferro-magnetic objects must not be carried into the magnet room. Persons using respiratory equipment must not enter the magnet room as long as the magnet is charged. The interruption of current does not influence the magnetic field. If it is absolutely necessary to enter the magnet room with ferro-magnetic objects, the magnet must first be discharged by depressing the emergency discharge button.

In the technical room fire extinguishers with CO<sub>2</sub> may be employed.

## C.2. Requirements for the Magnet Room

The location of all ferro-magnetic objects and materials existing in the vicinity of the proposed installation site must be determined and forwarded to BRUKER prior to the onset of the system installation.

Reinforced concrete made from ferro-magnetic steel up to 100 kg / m<sup>2</sup> can be used for the magnet base. If this limitation must be exceeded, other reinforcement materials e. g. glass fibre or stainless steel must be used.

All moveable ferro-magnetic objects must be removed prior to the installation.

It must be ensured that the free inner dimension at the magnet site above the magnet center is sufficient. If this inner height cannot be reached in a building already existing, special solutions are then necessary (e.g. filling the magnet with cryogenes from the upper floor or from inside the magnet room by using reduced and bendable transfer lines).

The site or the foundations of the magnet must be chosen such that the building vibrations do not exceed the allowed thresholds.

During site planning it is absolutely necessary to consider the floor surface on which the installation of the magnet will occur, as well as the weight-handling capacity of this surface.

### C.2.a. Air Ventilation

In compliance with safety regulations concerning work with cryogenes, the air ventilation system must be capable of exchanging approximately 1.5 times the room-volume air every hour.

Since such an air ventilation system can fail, we recommend a monitoring device for the in-flow of air into the ventilation system and for the O<sub>2</sub>-content in the room air. This monitoring device should be equipped with appropriate alarm mechanisms.

### C.2.b. Dimensions and Floor Loading

Type of Magnet	47/40USR	70/20AS	70/30USR	94/20AS
<b>Minimum free inner room dimension</b> (cm)	278	332	278	276
<b>Suggested on-floor space for the magnet area</b>				
Area (m. <sup>2</sup> )	~16	~16	~16	~16
Length (cm)	440	440	440	440
Width (cm)	360	360	360	360
<b>Weight-bearing area of the magnet</b>				
Magnet Foundation Area (m <sup>2</sup> )	~2.3	~2.1	~2.3	~2.8
Floor loading (kg per m <sup>2</sup> )	2087	1691	2957	1733
Length (cm)	184	167	184	178
Width (cm)	122	124	122	154

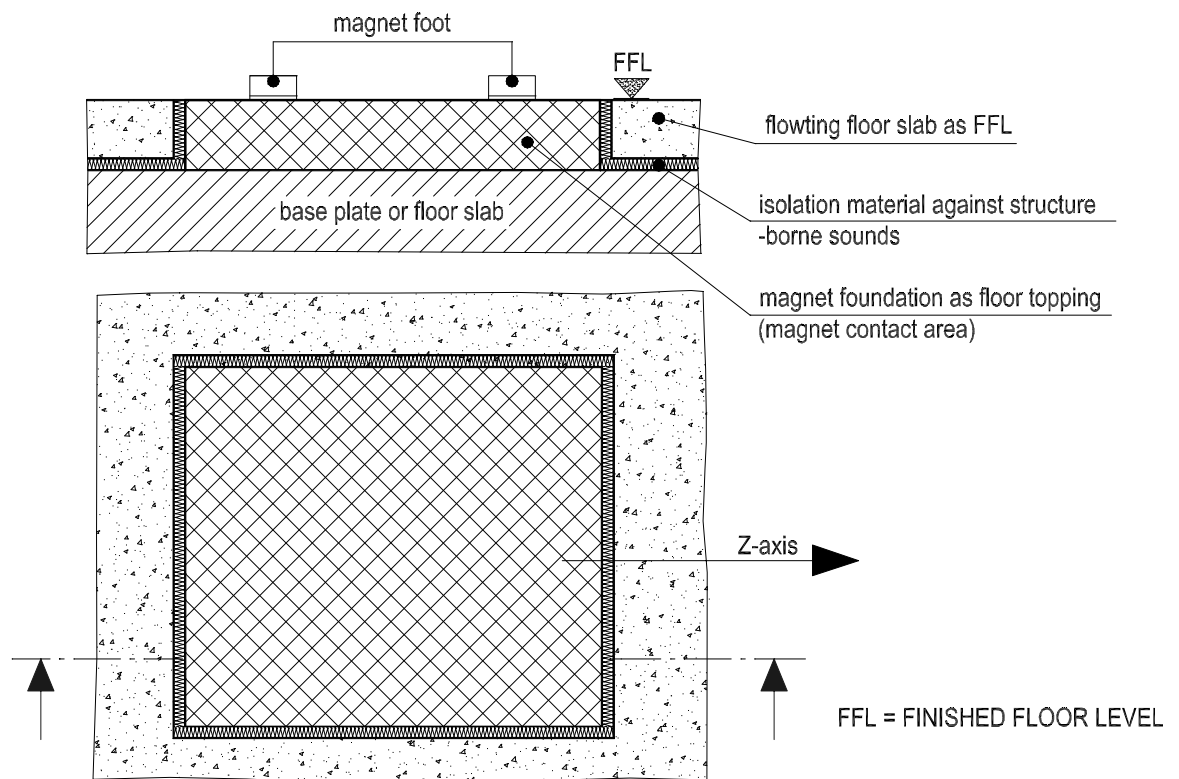

**Fig. C.2.: Schematic Diagram of a Magnet Foundation**

### C.2.c. Quench Tube (or Cylinder)

The delivery, assembly and connection of a gas-exhaust system (quench line) **is not included within the scope of a standard delivery**. The customer is responsible for such matters unless it is specified otherwise in the sale contract. The connection flange of the gas-exhaust system to the magnet represents the limit of the customer's responsibility.

The magnet is charged with cryogenic liquids. Cryogenic gases evaporate with an increase in volume approximately 700 times greater than that of the liquid state. This necessitates the installation of a quench system. For a quench pipe possessing a total length shorter than 12 m a tube with a cross-section of 15 cm is required. With these dimensions three 90° bends are possible. Other versions must be examined and approved by BRUKER. The outlet construction must make it impossible for animals, snow and the like to enter. Furthermore, the outlet must be constructed such that all risk of injury to individuals is avoided (a barrier at a distance of 3 m is recommended).

The quench line can be hand-made by a metal-worker as a sheet-metal cylinder composed of copper or stainless steel. The completed cylinder comprises a round ventilation tube; the surface of the cylinder may be covered as desired.

To avoid formation of condensed water, we recommend using strong insulation, approximately 40 mm in thickness.

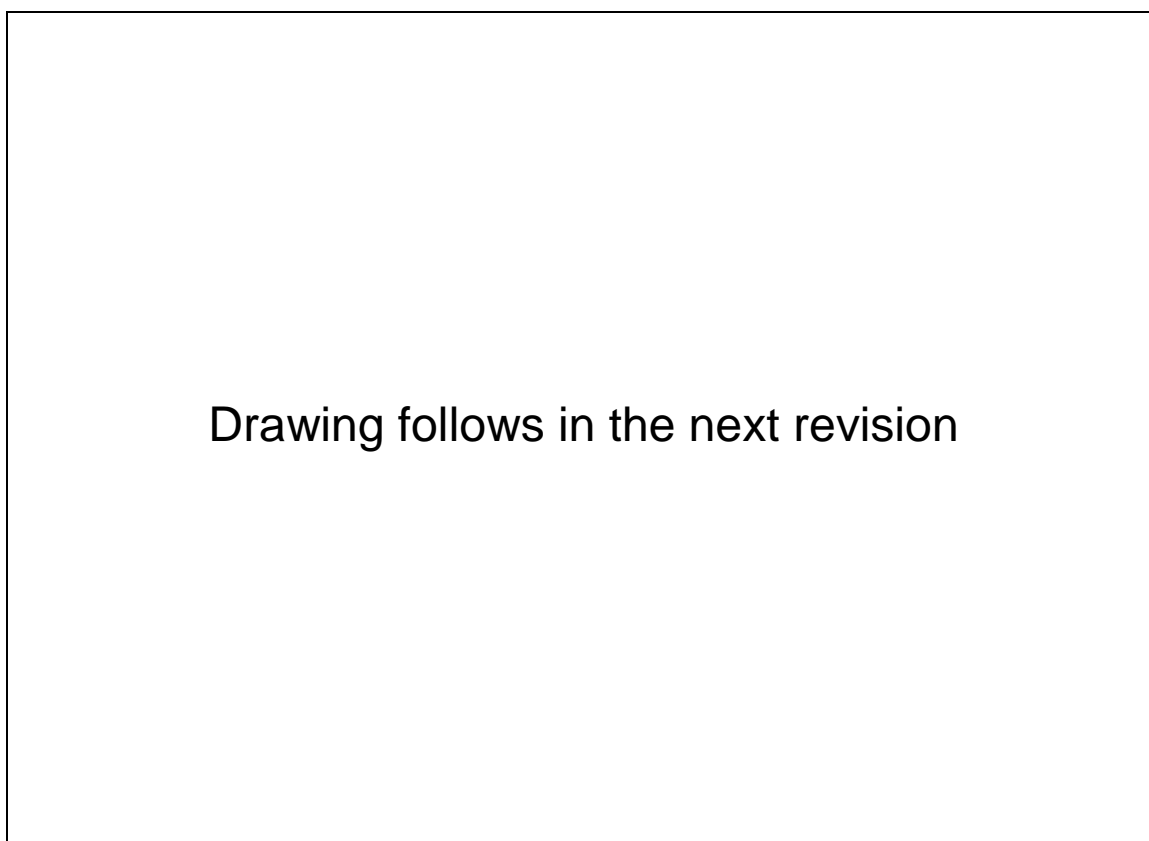

**Fig. C.2.: Connection Details Quench Tube**

**C.2.d. Opening for Magnet Transport**

For siting of the magnet an opening either in the wall (149 cm x 250 cm at minimum), in the roof of the building or in the ceiling (149 cm x 182 cm at minimum) is required.

**C.2.e. Cable trays between the Magnet and Cabinets**

A series of connection wirings must be placed between the electronic cabinets and the magnet. We prefer a direct path in a cable channel that will be connected to the rear of the magnet as an inspection stage (platform) or as a socket channel.

Since some of the cables are very rigid and can only be bent in large radii, the cabling should be laid so they are placed next to one another. The bend should have a radius of min. 10 cm.

Necessary dimensions: **Width: approx. 45 cm, Height: approx. 12 cm.**

If the cable way runs horizontally and the cables are mounted vertically one on top of the other, the cables must be anchored every 80 to 100 cm. The same applies to a vertical cable way for the tension relief.

**As standard connection cables, two different lengths are available:**

**Short length = 12 m, long length = 20 m.**

Greater connection lengths can be realized for particular situations. **Special solutions, however, do not comprise standard deliveries and therefore require BRUKER's approval.**

**Such particular situations, however, do not pertain to standard deliveries / installations and therefore require BRUKER's approval beforehand.**

### C.2.f. Light Fixtures

The lighting fixtures **do not comprise part of a standard delivery**. As a result of the high magnetic-field of the system and of the problems in operating electrical/ radio equipment in the vicinity of the system, we recommend the employment of halogen lamps.

Supply and installation of the lighting to the magnet area is provided by the customer. We recommend halogen lamps (230 V / 250 W) which are mounted on the wall and reflect on the ceiling to furnish indirect lighting. In cases where the perception of color is altered we recommend direct lighting from a low-volt halogen lamp (DC: 12 V / 50 W) positioned over the patient bed, which is supplied by a low-volt transformer. This can be mounted in the area of the filter plate. It must be ensured that the low-volt transformer must tolerate a magnetic-field strength at the installation site of about 1 - 5 Gauss. In our experience a lighting intensity of at least 500 Lux in the working area in front of the magnet is necessary. To avoid rf interferences switch mode power supplies, electronic transformers, dimmers or energy saving lamps are not allowed to be used close to the magnet.

### C.2.g. Acoustic Noise and Structure-Borne Sound Decoupling

Whenever an examination sequence is performed on the MR system acoustic noise is produced within the magnet room. Sound levels between 72 and 99 dB (A) can be measured at a distance of 1 m from the magnet bore during conventional scanning. Typical values are around approx. 86 dB (A). Examination sequences which incorporate extreme performance criteria may produce even higher sound levels. The system operator thus determines how great these sounds, or acoustic noise levels, will be during subsequent running of the examination sequence chosen.

During the installation site planning and the carrying out of the site construction it is important to consider the noise level anticipated in the vicinity of the operator's console and that system personnel will not be exposed to values which exceed established thresholds.

To avoid the propagation of vibrations, the magnet should stand on a rubberized platform or surface. In this fashion, the noise produced by the gradient switching will be decoupled from the area under the magnet. The relevant frequency range is between 50 and 800 Hz.

### C.2.h. Building Vibrations and Their Propagation

Every building displays mechanical vibrations which unfortunately have an acceleration effect on the magnet. The magnet system experiences these vibrations as a seismograph and reacts with alterations in the magnetic field which are proportional to the acceleration forces.

**If the vibrations within the frequency range of 3 to 40 Hz lead to acceleration forces exceeding 60  $\mu$ g significant image artifacts may appear. The performance specifications of the system can be guaranteed only when these acceleration forces are low in amplitude** (the drawing below specifies the positioning of the necessary measuring devices and their analogue circuit design).

Different construction measures can help in achieving these requirements. During site planning and the subsequent construction it must be ensured that floating floors do not have any contact with the magnet base. The magnet base must be in direct contact with the building, thereby ensuring the impact sound transmission will be decoupled. These measures are sufficient if the magnet will be sited in the basement. Should the magnet be sited on an upper floor these measures will prove insufficient since exterior forces also can act on the magnet.



Upon request BRUKER can measure the propagation of these vibrations and provide appropriate advice regarding the site of the system.

As a further option BRUKER also can deliver a system for flexible siting of the magnet. With this system acceleration forces of up to 200  $\mu\text{g}$  in the aforementioned frequency range can be tolerated. (60  $\mu\text{g}$  = 0,5886 mm/s<sup>2</sup>; 200  $\mu\text{g}$  = 1,962 mm/s<sup>2</sup>)

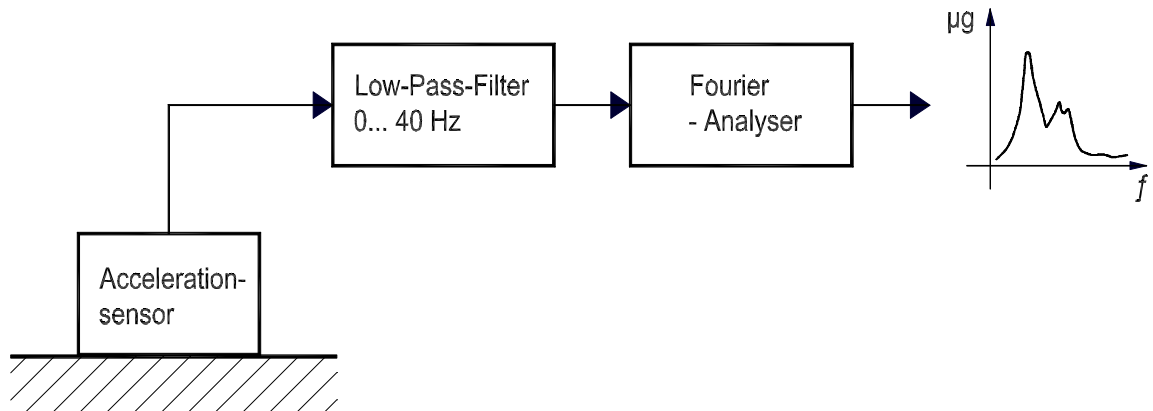

Fig. C.2.b: Arrangement Principle for Vibration Measuring Instruments

### C.2.i. Anesthesia Agents (Medical Gases)

In principal, the *BioSpec*® may be operated only with anaesthetic-gas devices which employ ISO-N-Fluorine.

Whenever anaesthetic gases (medical gases) are used, the ventilation must be dimensioned in accordance with the local regulations. In dimensioning the ventilation and evacuation equipment it is particularly important to observe the MWC values for the various anaesthetic agents used. This is especially valid for the area immediately surrounding the respiratory equipment (e. g. the MWC value for halothane is presently 5 ppm, where MWC = Maximal Working-area Concentration).

In Germany the DIN 1946 specifications (part 4) are in effect whenever choosing a ventilation system for a hospital. It has been defined that the air ventilation system must be capable of exchanging the room-volume air approximately 15 times every hour.

### C.2.j. Gaseous Helium Supply System 4.6 (> 99.996 volume %)

Pressurized gaseous helium is required during the filling of the magnet with liquid helium. This pressurized gas will be used to force the liquid helium from the transport container into the magnet. Recently it has become possible to use transport containers which do not require pressurized gaseous helium during the filling of the magnet.

Since it is not allowed to bring metallic objects (gas cylinders) into the area of the magnet, we recommend the installation of a fixed device comprising a mounting support for the gas cylinder and a release station in the technical room as well as a gas valve in the area of the magnet for additional security.

### C.2.k. RF-Shielding (Faraday Cage)

For disturbance-free operation of the MR system, the examination room must be shielded against external radio-frequencies (in the range of the system's operational frequency) with an efficacy of better than 80 dB. RF shielding manufactured by BRUKER guarantees this, **however the Faraday cage is not included with standard delivery of the system.**

Faraday cages may be constructed in a variety of manners. One is to incorporate pre-fabricated elements which are assembled on-site, another is to construct the cage using elements which are fabricated according to the site requirements and a final manner incorporates a combination of the two previous varieties.

## C.3. Requirements for the Technical Room

### C.3.a. Entrance Doors, Floor Strength

The minimum measurements of the entrance doors to the system's technical room are 80 x 200 cm. The floor strength must be checked, especially for the racks. Each rack stands on four disk feet, with a surface area of 28 cm<sup>2</sup> each.

### C.3.b. Acoustic Noise

Whenever an examination sequence is performed on the MR system acoustic noise is produced by the fans and the electro motors inside the cabinets in the technical room. Only the chillers can produce a sound level of 69 dB (A) each measured at a distance of 1 m. The total acoustic noise level depends on the system configuration and the spectrometer electronics. Typical total acoustic values in the technical room are approx. 73 dB (A).

During the installation, site planning and the carrying out of the site construction it is important to consider the noise level anticipated in the vicinity of the operator's console and that system personnel will not be exposed to values which exceed established thresholds.

### C.3.c. Ventilation Technique in the Technical Room

A room ventilation system is sufficient for operation of a *BioSpec*® system. For the capacity of the system please refer to point C.1.c.

### C.3.d. Cold Water Supply for Cryo-Refrigerator

The refrigerator for cooling the magnet releases its waste heat to the existing cold water piping. A chiller emits the heat dissipation in the air of the technical room. This chiller is a standard component of the system delivery (see table D.3 in this brochure).

For ecological reasons we recommend the use of the existing cold water piping. In case the water quality and the pressure do not meet the specifications of the refrigerator, a heat exchanger can be delivered instead of the chiller to decouple the cold water piping from the refrigerator.

For ecological reasons the installation of a stationary, decentralized cold water circuit is useful, e.g. closed cold water circuit in split construction for emission of the heat outside. Such a system can be delivered, installed and serviced by a local supplier. BRUKER can deliver such a system upon request but is not responsible for the installation and service.

C.3.e. Drawings of Components in the Technical Room

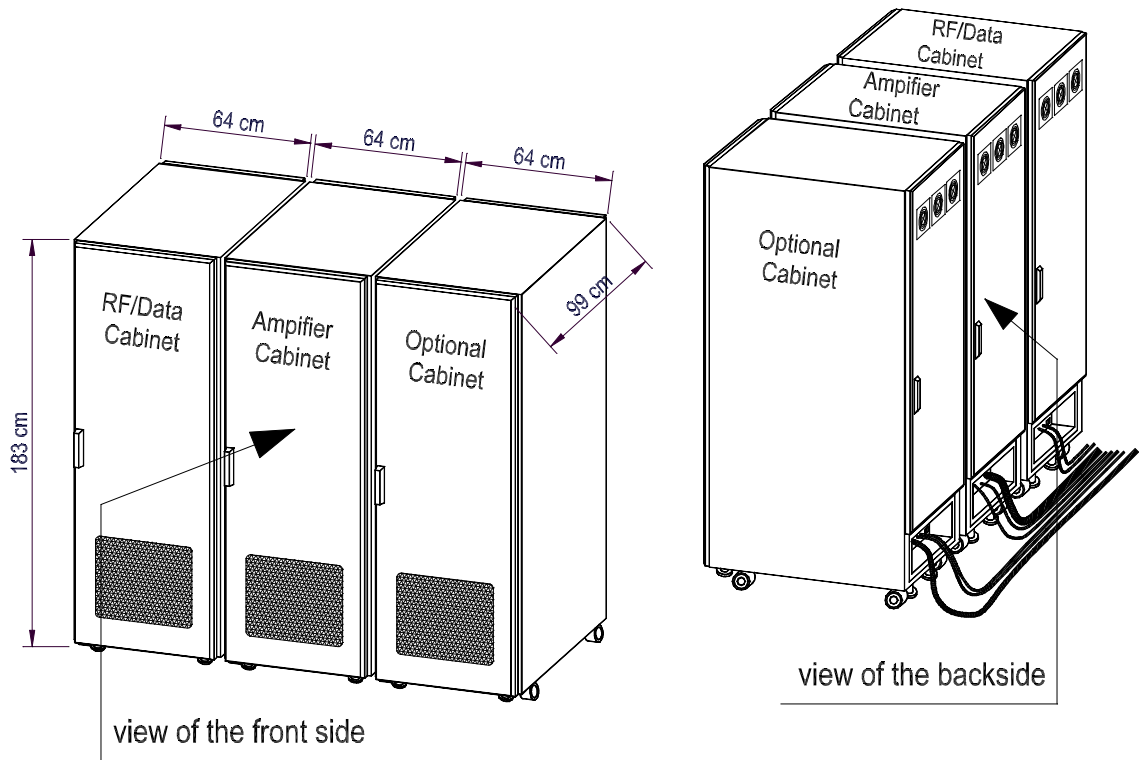

Fig. C.3.a: View of the System Cabinets

Type: CP 950/ CP 970

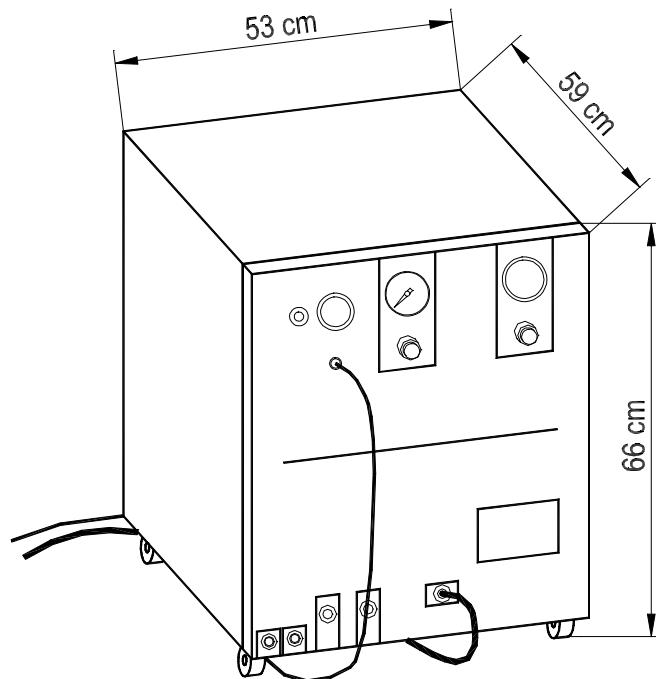

Fig. C.3.b: View of the Cryo-Refrigerator for Magnet Cooling

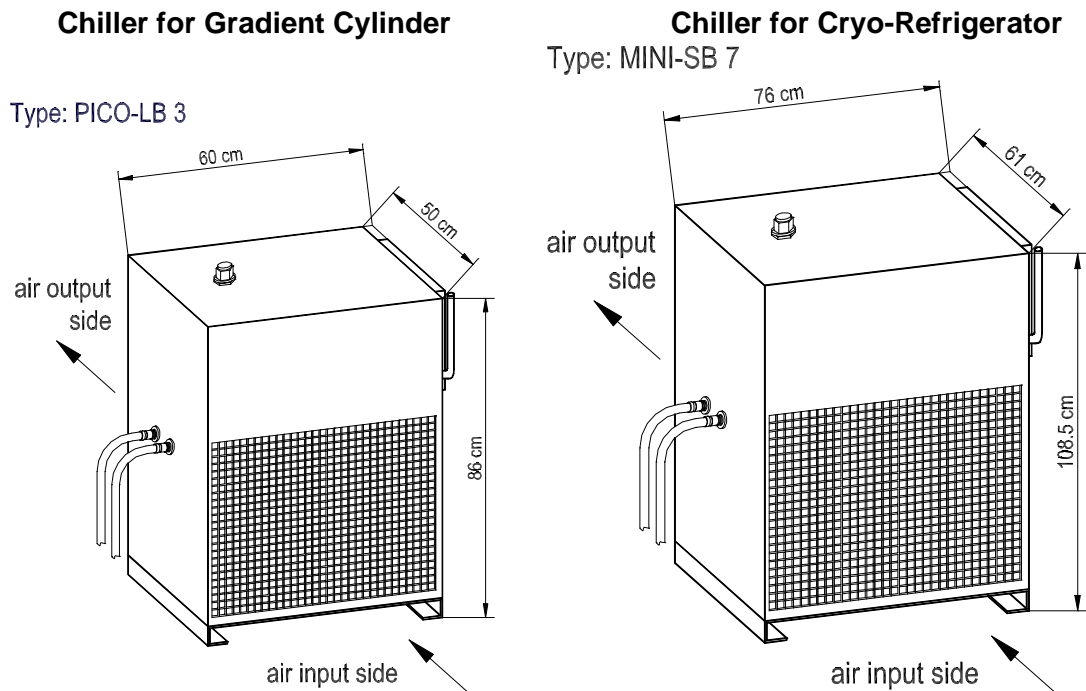

Fig. C.3.c: View of the Cooling Water Units (Recirculating Chiller Systems)

### C.3.f. Optional Components: Heat Exchanger for Cryo-Refrigerator

Alternatively to the chiller we can deliver an heat exchanger to decouple the existing cold water piping from the refrigerator loop. This allows the heat transfer from the initial heat source to the cold water piping without any additional heat dissipation into the air.

When sizing the air condition system it must be taken into consideration that the waste heat of the refrigerator will be released into the cooling water piping instead of the air. For details see table D.3.

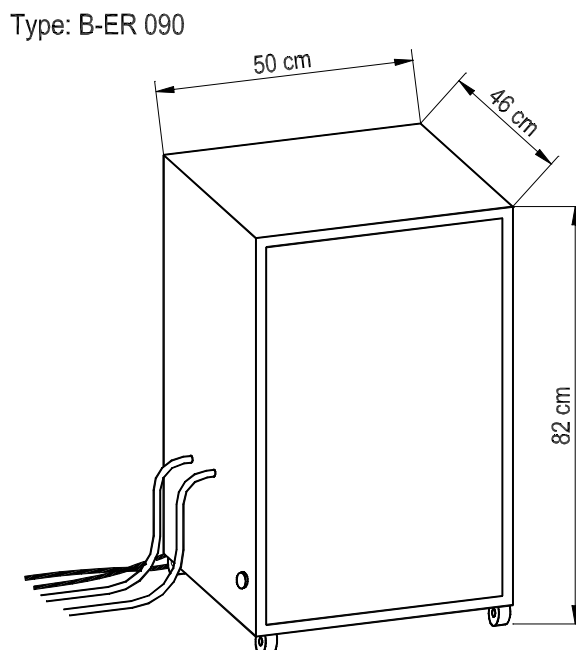

Fig. C.3.d: View of the Heat Exchanger (B-ER 090)

**C.3.g. Cooling Water Connections for the Heat Exchanger: B-ER 090**

The piping to the connection points for inflowing and out flowing water must possess a diameter of 3/4 inch and be composed of either copper or PVC. The piping must be protected against condensation, at least within the technical room. The connection between this piping and the refrigerator will be made with a high-pressure hose included in the delivery of the BioSpec®. For this connection to the 3/4 inch hose, the end of the piping should have an externally-threaded connector with an outer diameter of 1/1 inch. The end of the piping has to be oriented such that the hose is connected from below. The connection should be at a height of 55 cm above the floor. Prior to the end of the piping a ball valve must be installed.

**C.3.h. Cooling Water Requirements for the Heat Exchanger: B-ER 090**

- Intake cooling water temperature: 5 °C - 20 °C
- Temperature stability of the cooling water: no special requirements
- Pressure stability of the cooling water: no special requirements
- Maximum pressure: 16 bar
- Maximum pressure difference intake/outlet: 6,0 bar
- Minimum pressure difference intake/outlet: 2,5 bar
- Minimum necessary cool performance: 8.5 kW
- Typical water flow: 25 l/min
- Minimum water flow: 10 l/min
- PH-value of the cooling water: 6 - 8
- Suspended matter after the filter : less than 10 micrometer (10 microns)
- Water hardness: 7 - 10 °d (German scale)
- Water quality:

The compression units possess a countercurrent - heat exchanger made from copper. To prevent excessive calcification in the heat exchanger the degree of water hardness should be maintained within the range of 1.25 to 1.8 mmol/l.

1 mmol / l	=	5.6° d,	German scale for water hardness.
	=	7.02° e,	English scale for water hardness.
	=	10.0° f,	French scale for water hardness.
	=	5.85° a,	American scale for water hardness.

If water having markedly different properties is used, the deposit of chalk in the heat exchanger may impede the flow of water and heat removal. Therefore under such circumstances the heat exchanger should be decalcified at regular intervals.

## C.4. Requirements for the Operating Room

### C.4.a. Lighting and Window Surfaces

It must be ensured that the regulations for working at visual display units are followed (DIN 66234, Part 7).

This means:

The operating console and lighting devices must be installed in conjunction. It should be realized that any glaring or any direct beaming of light on the monitor surfaces should be avoided. Window surfaces in the vicinity should be darkened to the extent that glaring is eliminated. This requirement is met essentially if the luminous power does not exceed the lighting power stipulated (up to a maximum of 300 Lux). Neighboring or background areas (walls or ceiling) should be darkly painted without a reflected surface.

### C.4.b. Air-Ventilation Technique

As the heat emission of the devices in the operating room is very low it is not absolutely necessary to install a ventilation system. Room temperatures of up to 35 °C are not dangerous for device operation.

### C.4.c. Cable Terrace for System Wiring

A series of connection wirings must be placed between the electronic cabinets and the magnet. We prefer a direct path in a cable channel, that will be connected to the rear of the magnet as a socket channel or as an inspection stage (platform).

**The standard length of this connection cable is 25 m.**

Greater connection lengths can be realized for particular situations.

**Such particular situations, however, do not pertain to standard deliveries / installations and therefore require BRUKER's approval beforehand.**

### C.4.d. Telephone / Internet / Intranet

A telephone connection near the operating console is necessary for service purposes. Access to internal and external networks enables data exchange and technical support through BRUKER directly.

## C.5. Storage Room for Cryogen Gases

Cryogen gases are supplied in transportation dewers and then stored for several days. Special precautions must be taken in the storage room:

**In closed rooms there exists the danger of asphyxiation.**

The storage room must be supplied with an air-ventilation system. We recommend an oxygen supervisor with an alarm device and an automatically-switched exhaust system. We further recommend strictly observing the guidelines specified in documents such as TRGS 220 for inert and liquefied gases.

## **C.6. Route of Transport for Cryogen Gases**

Access doors of all transport routes must have internal dimensions of at least 100 x 200 cm.

When cryogen gases are transported in a closed elevator, simultaneous use by individuals is not allowed. Very small rooms (e. g. a corridor) in which the shortage of oxygen can theoretically occur, may constitute a portion of the transport route only if appropriate written permission (from the relevant technical or governmental authorities) has been granted and all necessary security precautions implemented beforehand.

The customer is responsible for all necessary security precautions.

## **C.7. Emergency Room, Emergency Plan**

In case of a medical emergency the emergency treatment must take place outside the magnet area, in another room specially equipped as an emergency room (this room may be used for other purposes as well).

The user of an MR-system has the obligation to draw up an emergency plan with instructions for the security and cleaning personnel as well as for the responsible fire brigade.

## D. Planning Data of the Electronics Components

<b>D.1 Magnet Room</b>	Length (Depth)	Width	Height	Weight	Power con- sumption	Heat into air
	<b>cm</b>	<b>cm</b>	<b>cm</b>	<b>kg</b>	<b>kW</b>	<b>kW</b>
a) Magnet with Various Small Units: Preamplifier, etc.)					0.1	0.2
b) Filterbox	28	80	110	68		
c) Animal Support Table	80	40				
d) Emergency Quench Unit (wall-mounted)	30	45	18		0.03	0.03

<b>D.2 Operating Room</b>	Length (Depth)	Width	Height	Weight	Power con- sumption	Heat into air
	<b>cm</b>	<b>cm</b>	<b>cm</b>	<b>kg</b>	<b>kW</b>	<b>kW</b>
a) Operating Console	117	120	145	140	0.4	0.4
b) Various Small Units					0.1	0.1



## D. Planning Data of the Electronics Components

<b>D.3 Technical Room "A"</b> Standard Configuration for BRUKER USR - Magnets: (47/40USR and 70/30USR)	Length (Depth)	Width	Height	Weight	Power con- sumption	Heat into air (into water)
	cm	cm	cm	kg	kW	kW
a) DATA Cabinet	96	64	183	360	1.6	1.6
b) Amplifier Cabinet (RF-Pulse Amp. 2 parts of 1 kW) (Gradient Amp.: Copley 231P)	96	64	183	345	1.9	1.8
c) Refrigerator (Cryomech CP970)	58	53	66	119	7.0	0.1 (7.1)
d) Cooling Water Unit Circulating Chiller System for Refrigerator (KKT Type: MINI-SB 7)	76	61	109	150	2,9	10.0
e) Cooling Water Unit Circulating Chiller System for Gradient Cylinder (KKT Type: PICO-LB 3)	60	52	86	120	1.2	1.8
f) Line Power Distributor	24	80	65	35		

<b>D.3 Technical Room "A"</b> Optional components	Length (Depth)	Width	Height	Weight	Power con- sumption	Heat into air (into water)
	cm	cm	cm	kg	kW	kW
1) Gradient Amplifier: Copley 262NH (Additional data for cabinet: D.3.b)				32	0.8	0.8
2) Gradient Amplifier Cabinet: Copley 265P (Deductible data for cabinet: D.3.b)	96	64	183	390 (-56)	1.4 (-0.6)	1.3 (-0.6)
3) Multiple RF-Channel Cabinet	96	64	183	260	1.2	1.2
4) Heat Exchanger for Refrigerator (Type: B-ER 090) (Don't use comp. point D.3.) (Deductible data for standard results.)	46	50	82	54	1.0	0.2  (-7.9)

## D. Planning Data of the Electronics Components

<b>D.3 Technical Room "B"</b> Standard Configuration for Magnex AS - Magnets: (70/20AS and 94/20AS)	Length (Depth)	Width	Height	Weight	Power con- sumption	Heat into air (into water)
	cm	cm	cm	kg	kW	kW
a) DATA Cabinet	96	64	183	360	1.6	1.6
b) Amplifier Cabinet (RF-Pulse Amp. 2 parts of 1 kW) (Gradient Amp.: Copley 231P)	96	64	183	345	1.9	1.8
c) Cooling Water Unit Recirculating Chiller System for Gradient Cylinder (KKT Type: PICO-LB 3)	60	52	86	120	1.2	1.8
d) Line Power Distributor	24	80	65	35		

<b>D.3 Technical Room "B"</b> Optional components	Length (Depth)	Width	Height	Weight	Power con- sumption	Heat into air
1) Gradient Amplifier: Copley 262NH (Additional data for cabinet: D.3.b)				32	0.8	0.8
2) Gradient Amplifier Cabinet: Copley 265P (Deductible data for cabinet: D.3.b)	96	64	183	390 (-56)	1.4 (-0.6)	1.3 (-0.6)
3) Multiple RF-Channel Cabinet	96	64	183	260	1.2	1.2

## E. Specifications of Various Magnet Types

Type of Magnet	B 47/40USR	M 70/20AS	B 70/30USR	M 94/20AS
<b>Field strength</b> (Tesla)	4.7	7.0	7.0	9.4
<b>Larmor-frequency (1H)</b> (MHz)	200	300	300	400
<b>Helium capacity</b> maximum (liters)	800	750	800	800
Typ. refill interval (days)	365	90	365	100
Typ. refill quantity (liters) (losses during transfer inclusive)	~450	~276	~450	~340
<b>Nitrogen capacity</b> maximum (liters)	0	180	0	200
Typ. refill interval (days)	-/-	12	-/-	14
Typ. refill quantity (liters) (losses during transfer inclusive)	-/-	~176	-/-	~198
<b>Liquid gas for installation</b> (litre) <b>warm transport</b>				
Helium	not	2500	not	2500
Nitrogen	usual !	2500	usual !	2500
<b>Liquid gas for installation</b> (litre) <b>cold transport</b>				
Helium	350	not	350	not
Nitrogen	-/-	possible !	-/-	possible !
<b>Height of magnet iso-center</b> (cm)	110	107	110	109
<b>Minimum free inner room height</b>	278	332	278	276
<b>Dimensions</b> (cm)				
Length	144	128	144	142
Width	166	172	166	176
Height	241	233	241	245
<b>Weight</b> (kg)	<b>4800</b>	<b>3550</b>	<b>6800</b>	<b>4850</b>
<b>Loading capacity of surface</b> (kg /m <sup>2</sup> )	2087	1691	2957	1733
<b>Transport data</b>				
Standard dimensions (cm)				
Length	164	148	164	162
Width	186	192	186	196
Height	256	231	256	240
Minimum dimensions (cm)				
Length	149	133	149	147
Width	176	182	176	186
Height	250	226	250	235
<b>Weight</b> (kg)	<b>4500</b>	<b>3300</b>	<b>6500</b>	<b>4600</b>

**E.1.a. Side/Front-View of BioSpec® B-C 47/40USR.**  
 (View of the Magnet with Filter Box on Service End)

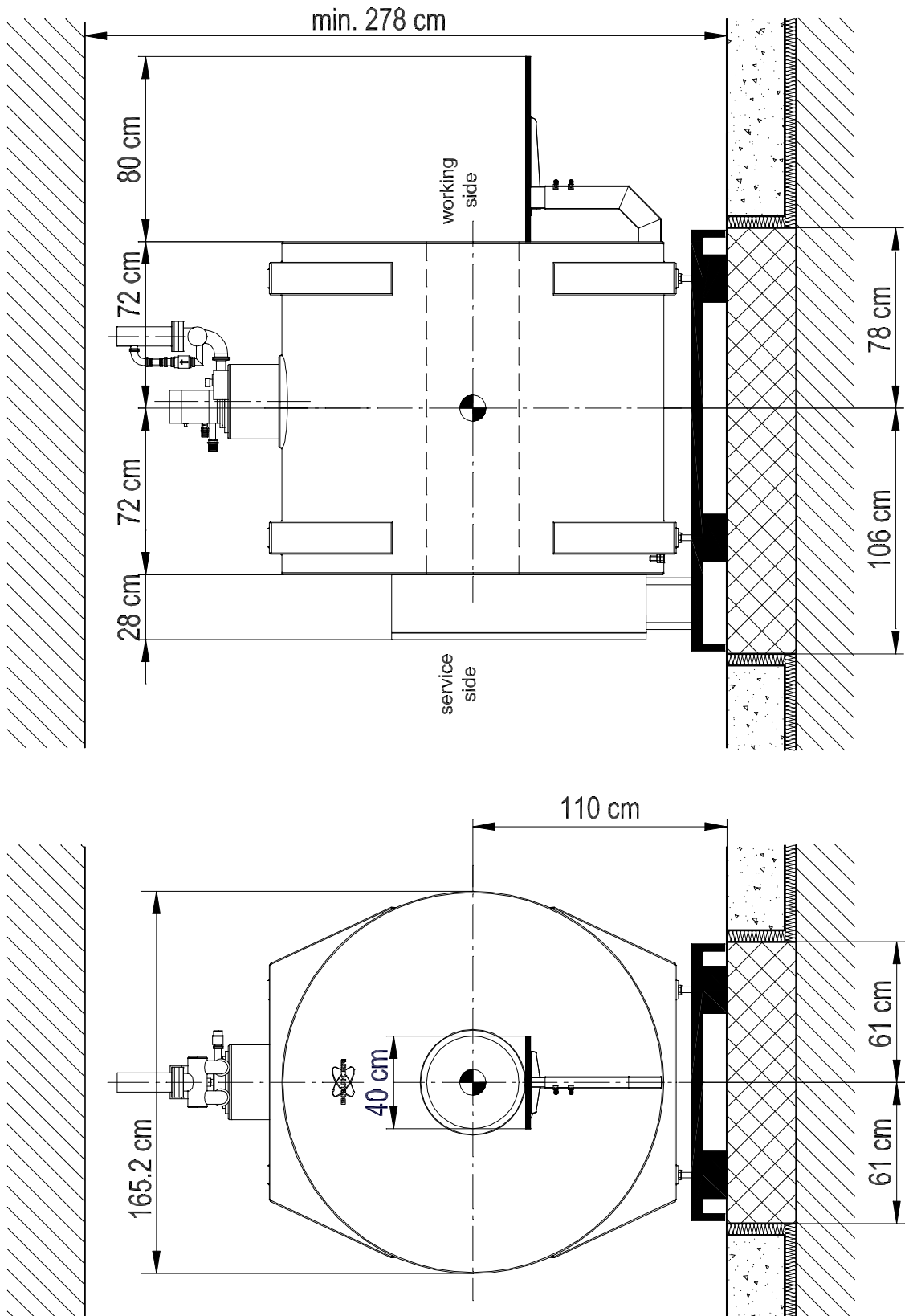

**E.1.b. Stray-Field: B-C 47/40USR (Actively Shielded).**  
Scale 1:25

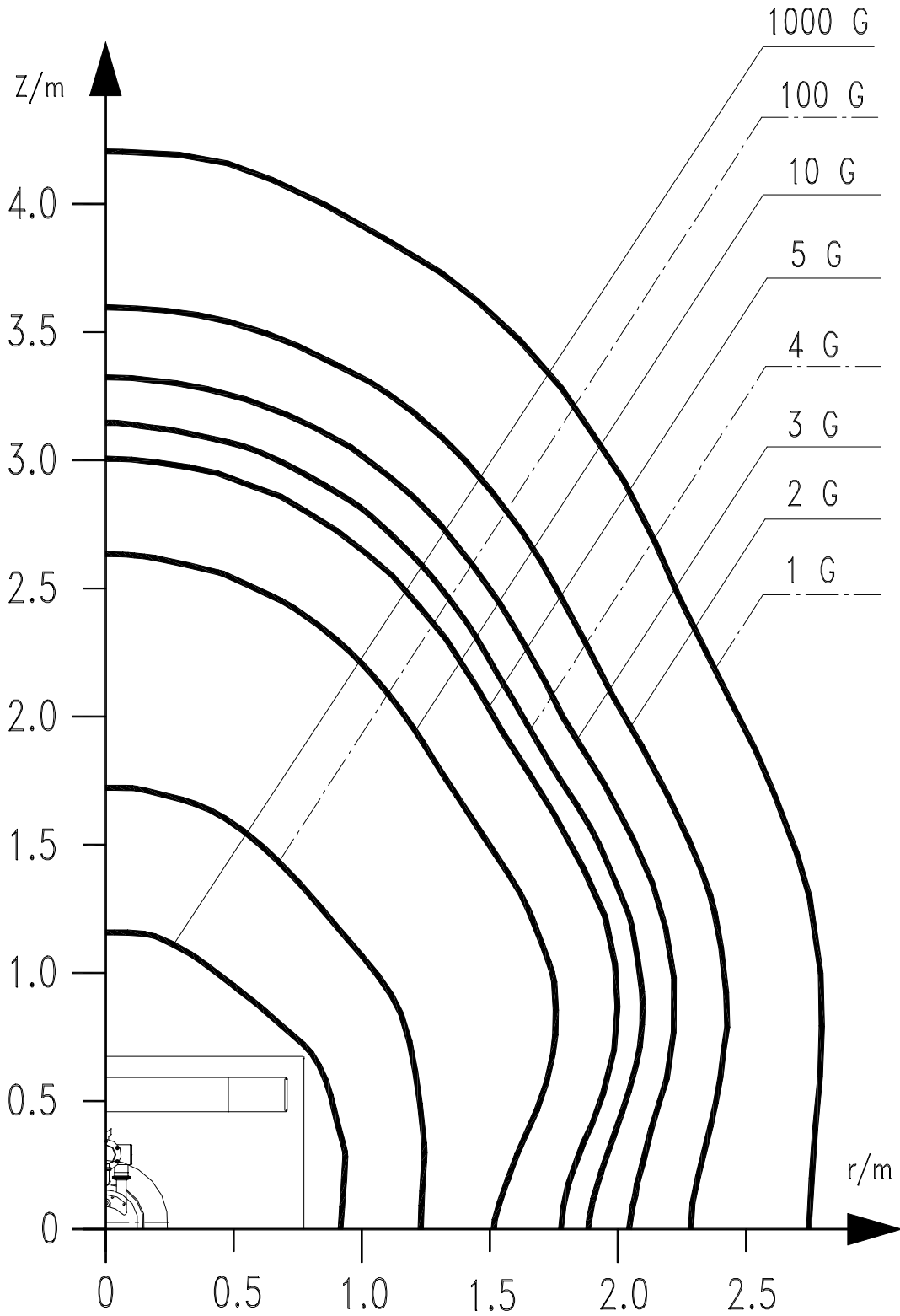

**E.2.a. Side/Front-View of BioSpec® M-C 70/20AS.**  
(View of the Magnet with Filter Box on Service End)

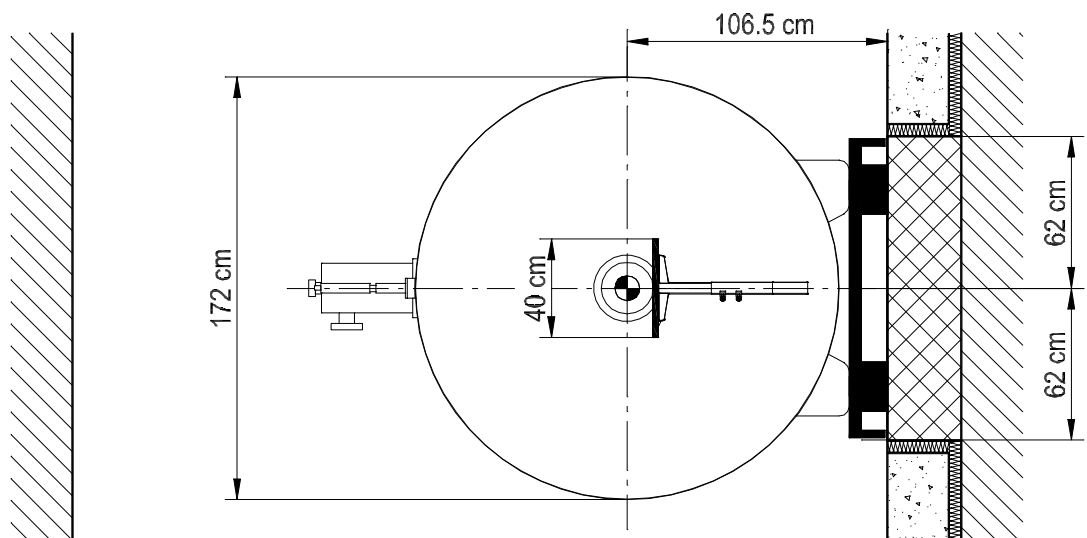
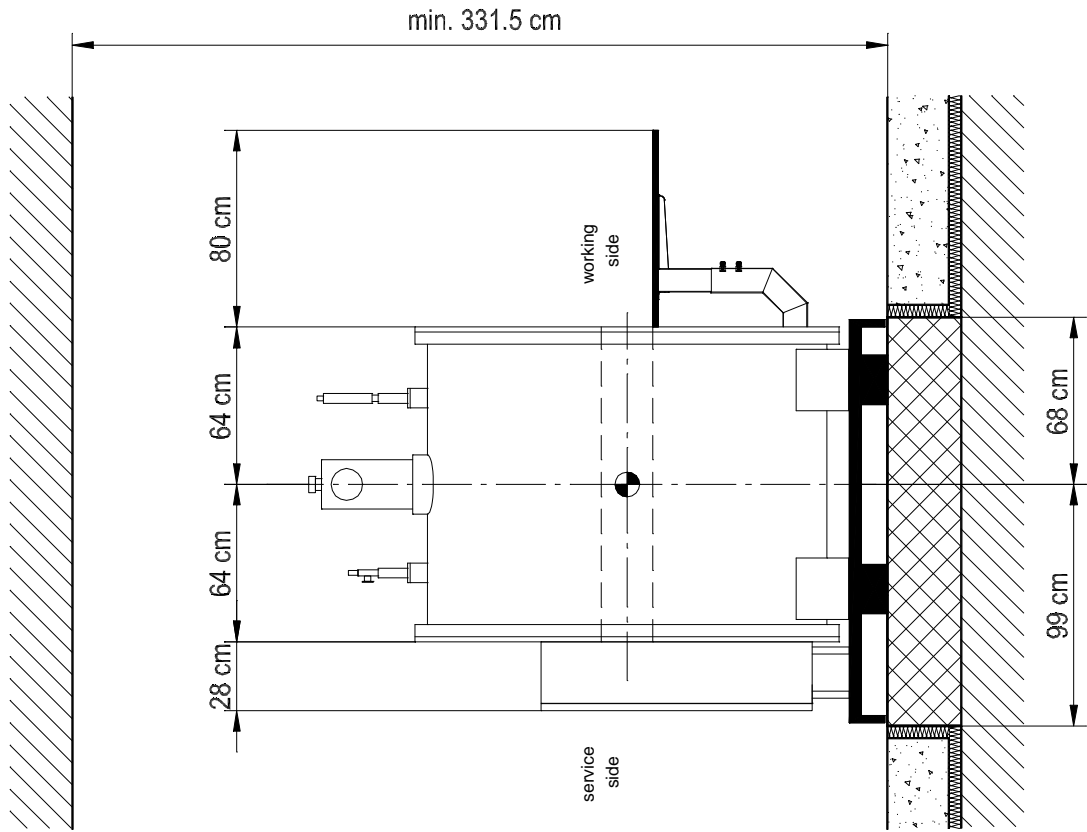

**E.2.b. Stray-Field: M-C 70/20AS (Actively Shielded).**  
Scale 1:20

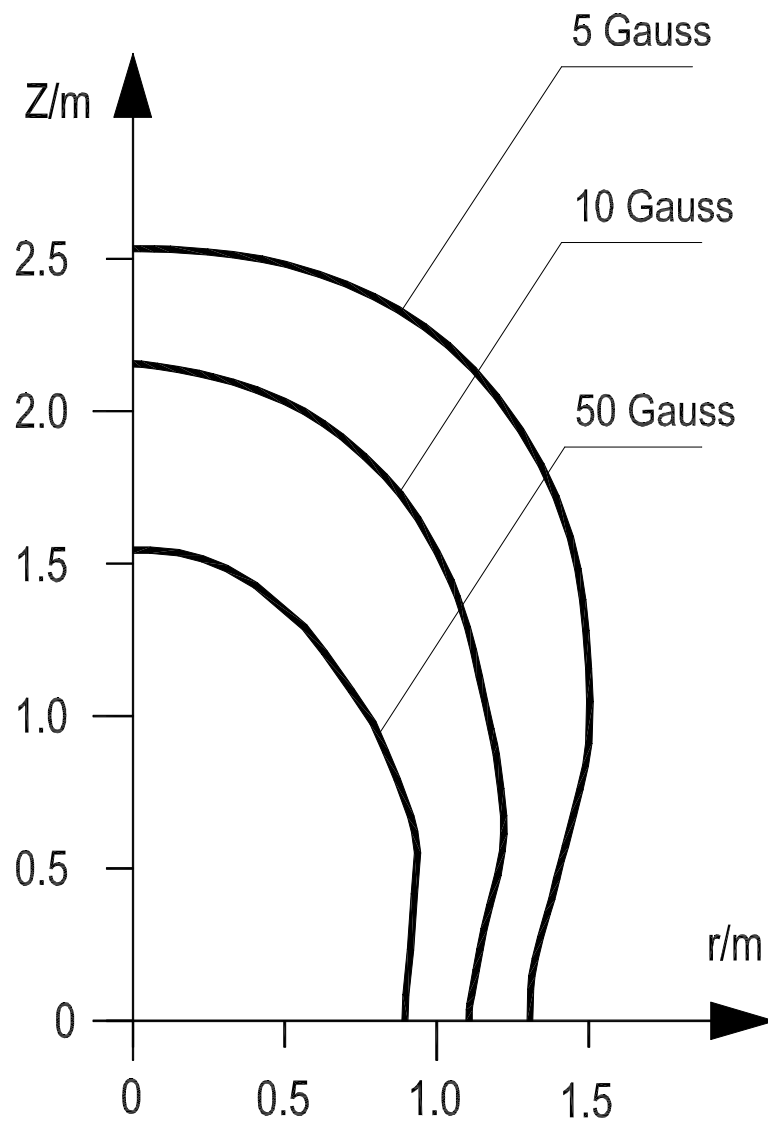

**E.3.a. Side/Front-View of BioSpec® B-C 70/30USR.**  
 (View of the Magnet with Filter Box on Service End)

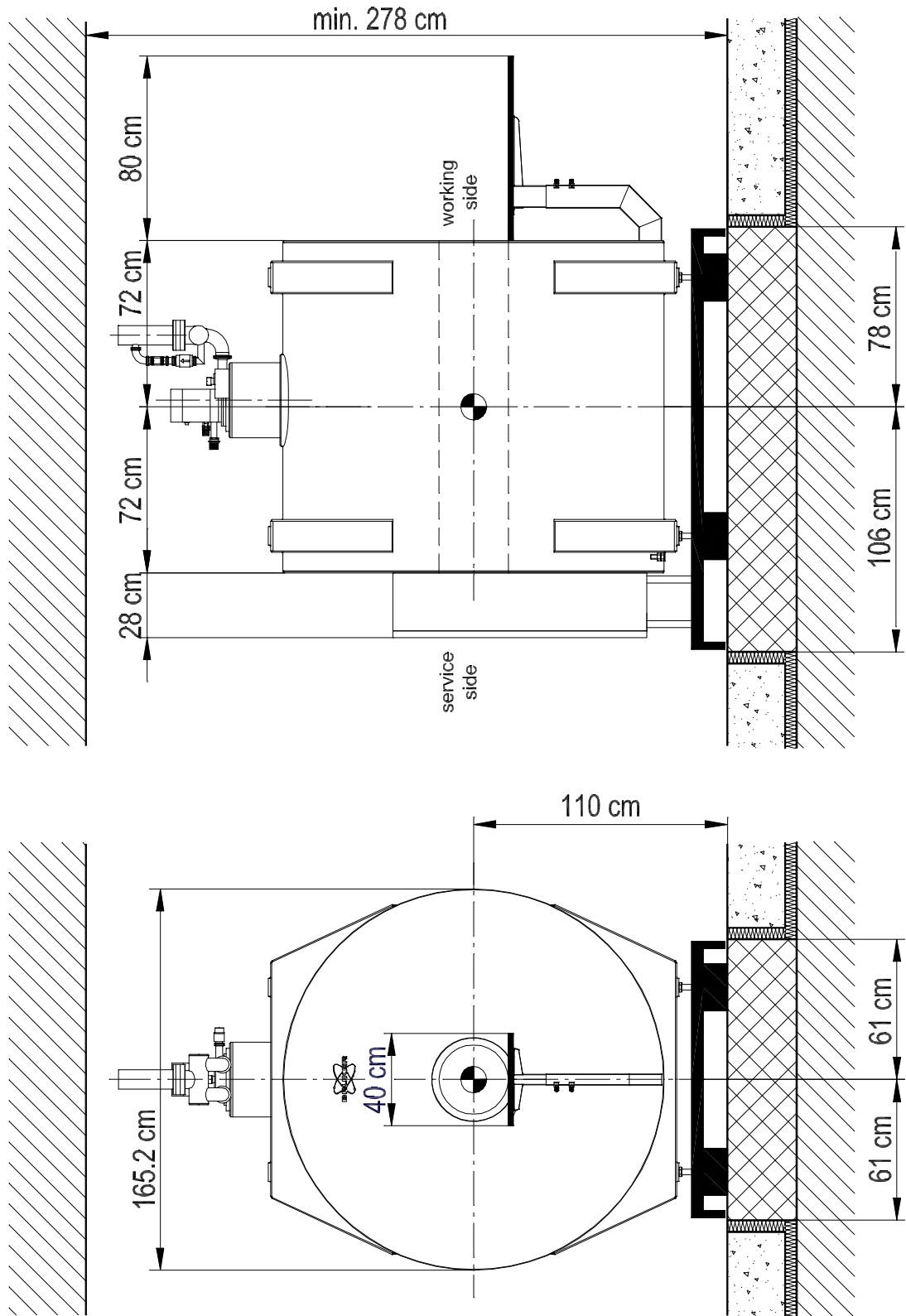



**E.3.b. Stray-Field: B-C 70/30USR (Actively Shielded).**  
Scale 1:25

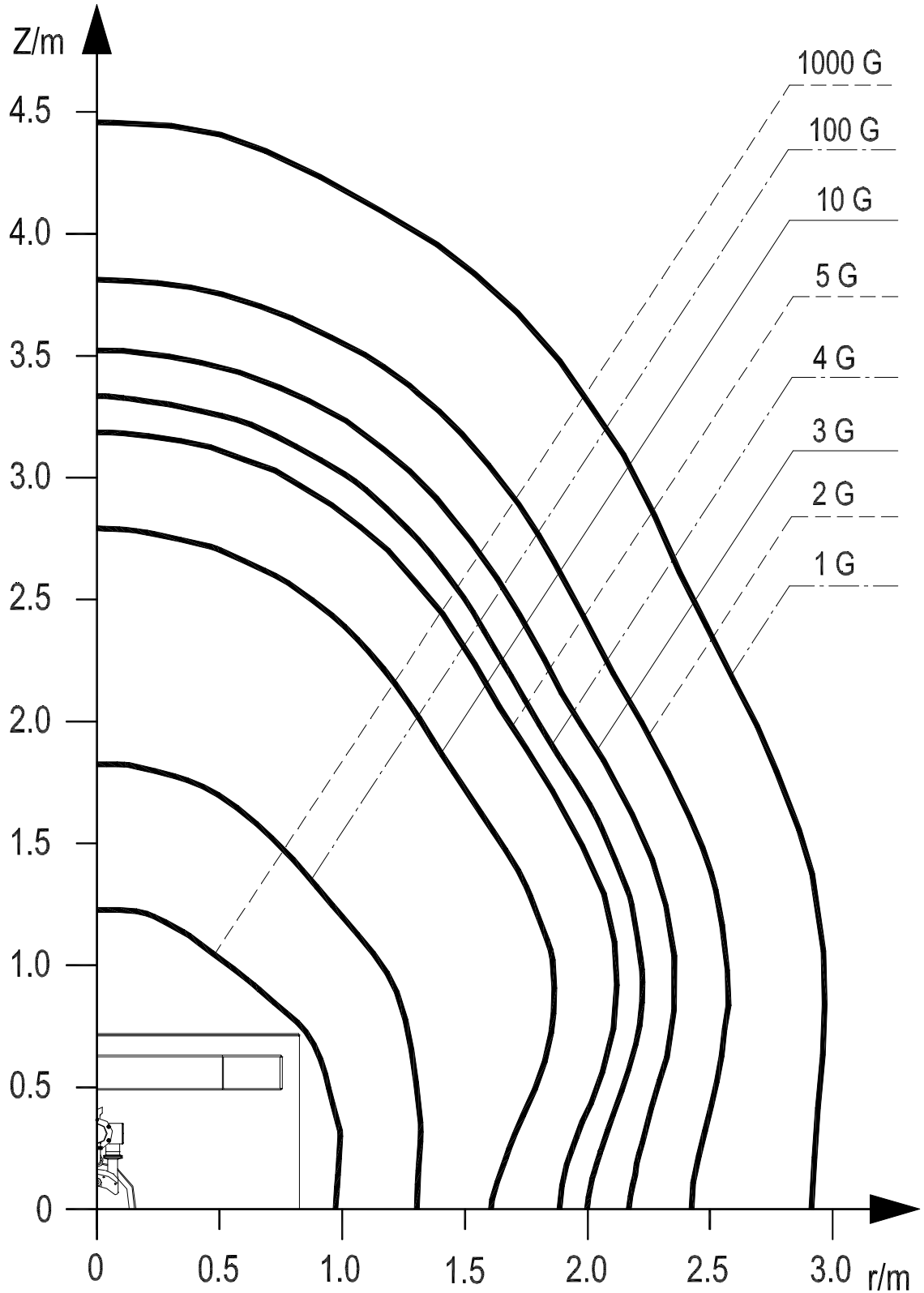

**E.4.a. Side/Front-View of BioSpec® M-C 94/20AS.**  
 (View of the Magnet with Filter Box on Service End)

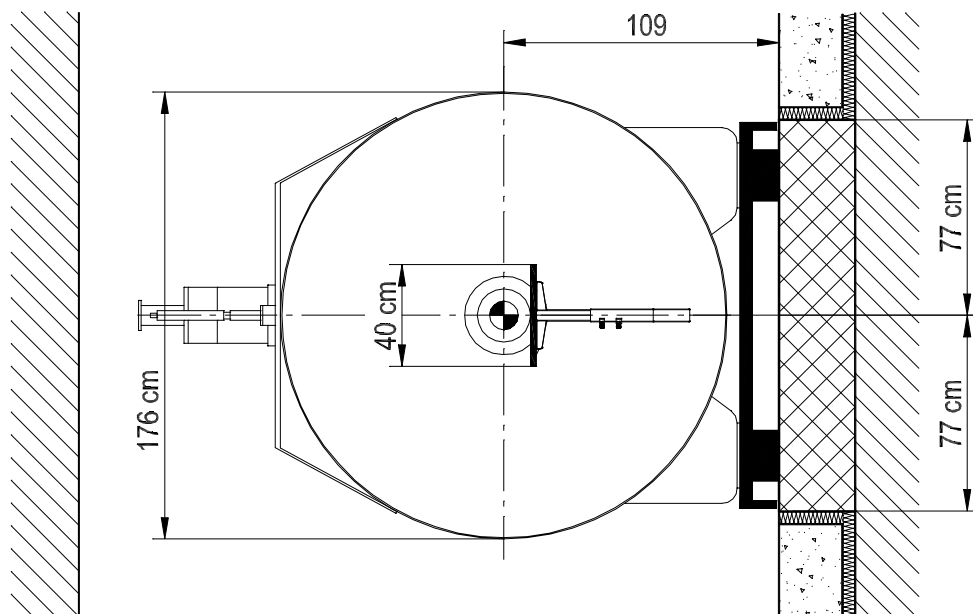
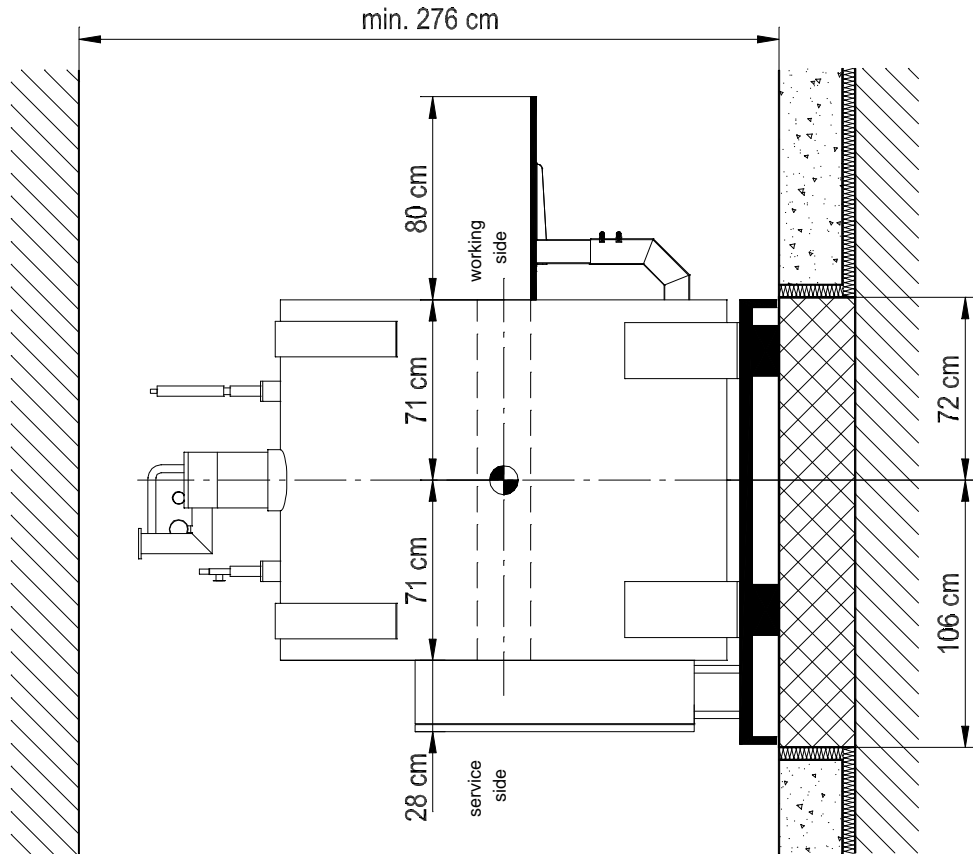

**E.4.b. Stray-Field: M-C 94/20AS (Actively Shielded).**  
Scale 1:20

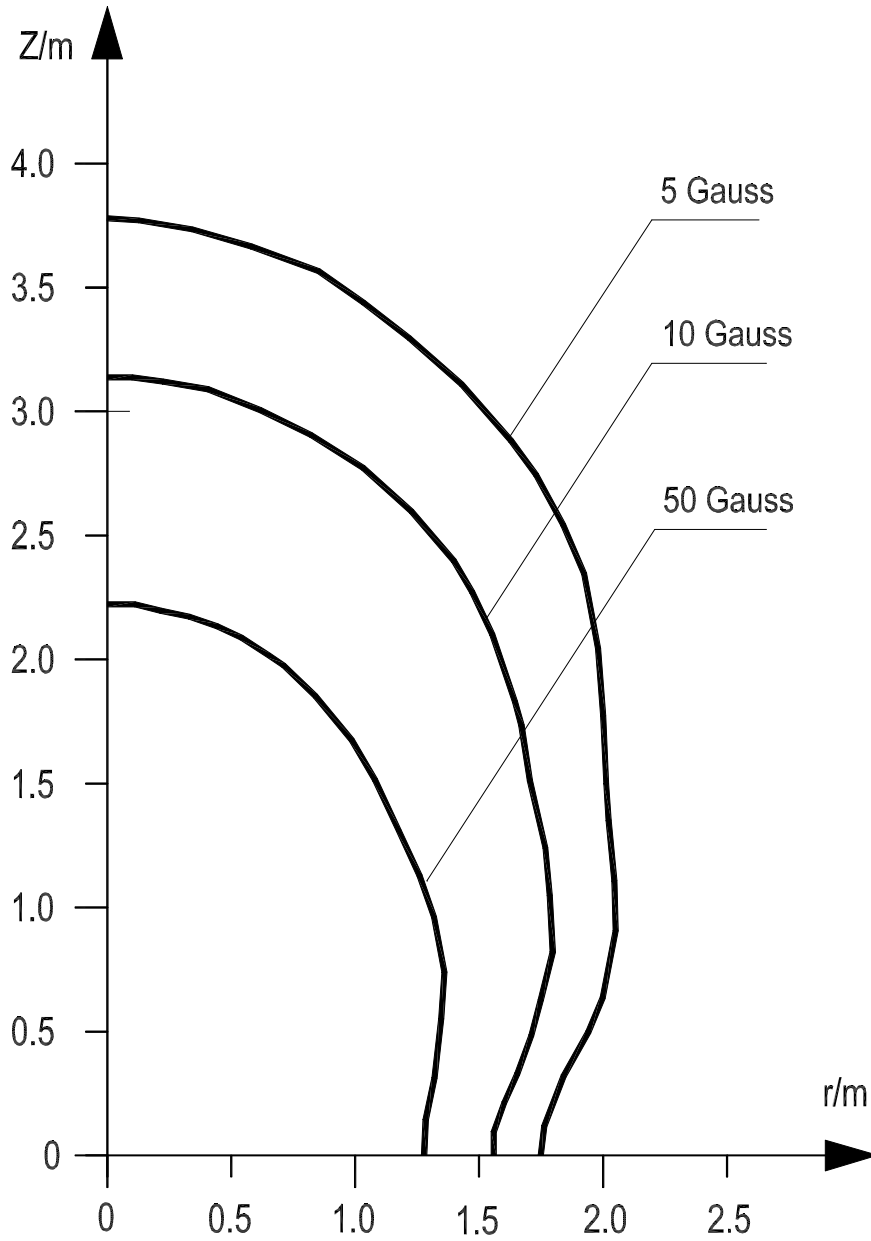

## **F. Important Instructions for System Installation**

### **F.1. Installation**

(Extract from our „Terms and Conditions of Sale“)

It is the responsibility of the Customer and at his own expense to prepare the site according to proper environmental requirements and to provide all the services requisite or necessary to enable such an installation to be effected as expeditiously as practicable including, but not restricted to power, water, drain, air, bottled gases, permits, licenses and approvals. Customer must also provide at his own expense whatever is required, including labor to uncrate and move the goods into their final location. Failure to so prepare and provide may result in a service charge by BRUKER to cover lost time on the part of its service engineers. Customer shall advise BRUKER within 60 days of written acceptance by BRUKER of the purchase order of details of all safety, building and electrical codes which must be complied with relevant to the installation of the goods. Any additional costs to BRUKER of complying with the requirements of such codes shall be added to the Contract Prices and paid for by Customer. If any certificates or other approvals by governmental and/or other authorities are required for the installation, the same shall be procured by Customer without delay and at his own expense.

### **F.2. Passing of Risk**

(Extract from our „Terms and Conditions of Sale“)

Risk passes to Customer as soon as the goods have left BRUKER's premises (i.e. postal delivery, transport by BRUKER itself, etc) or have been delivered to the forwarding agent or as soon as Customer has been advised by BRUKER that the goods are ready for dispatch. This applies mutatis mutandis for partial deliveries and the delivery of spare parts.

### **F.3. Prerequisites for the Installation**

Before the installation is performed by BRUKER, the said party shall meet the following requirements:

- All earthwork, concrete work, cutting work, construction work, etc. is completed
- The rooms planned for the installation must be clean and ready for occupancy
- Power, including fuels and all necessary connections leading to the installation site, heating, lighting and air-conditioning, installation of mains, electric connections, cable channels, pipes, etc. are available
- Safety measures have been taken and, when necessary, safety barriers have been installed
- Provide routes of transport of sufficient dimensions with regards to width and height, and of sufficient load bearing capacity, both inside and outside the building
- Provide spacious and dry rooms to store service and installation materials and equipment (approx. 18 m<sup>2</sup>)
- During the installation the access of individuals to the installation area and to the neighboring rooms (which may be locked by BRUKER personnel) must be controlled. Within this time period, admittance to these areas requires prior approval from BRUKER personnel
- Objects and materials required and assistant workers made available or can be made available at short notice

## F.4. Transportation of the Magnet to Installation Site

### F.5.a. General Handling and Lifting Procedures

The BRUKER USR magnets are designed such that they are sufficiently strong to be shipped without disassembly and in cold condition, thus the strength is optimized so as not to affect the cryogenic performance. However, care must be exercised when handling the magnet since abnormal forces due to faulty or careless handling practices may damage the system.

All lifting and moving of the magnet containing cryogenic gases (liquids) must be carried out by trained personnel and under no circumstances may the system be dropped or skidded along the floor because these actions damage the magnet system.

The magnet must be moved in an upright position by using appropriate transportation means (e.g. air pads). When moving the magnet, it should not be tilted by more than 3 degrees.

With any type of movement the resulting acceleration forces must be smaller than 2.0 g. When movement occurs in the vertical direction alone, forces of up to 3.0 g can be tolerated. However, in such cases no acceleration forces whatsoever may be experienced simultaneously in another direction (acceleration forces ( $g = 9,81 \frac{m}{s^2}$ )).

### F.5.b. Moving

It is preferable to move the system on air pads but if unavailable, skates may be used. If skates are used, the surface must be true, which may mean laying plates on the floor before moving the magnet. The system must be supported on the pads or skates directly under the feet of the cryostat. This must be carried out by experienced personnel.

The system must not be allowed to fall off the pad or skate, but must be gently lowered to the floor.

Bending of support constructions and ascents (inclines) by more than 2 mm must be avoided.

### F.5.c. Lifting

During transportation it is recommended that the magnet is lifted by the packing crate, using either a crane or a fork-lift truck.

Lifting, lowering and traversing must be carried out at low speed. Care must be taken not to grab when lifting or drop when lowering. The system must not impact other objects when traversing.

**Important:**

**The transport lugs should not experience any lateral forces at any time!**

### F.5.d. Crane Operation

Lifting, lowering and traversing must be carried out at low speed. Care must be taken not to grab when lifting or drop when lowering. The system must not impact other objects when traversing.

Any crane and equipment used to move the magnet must have a safe working load equal to, or greater than, 7 000 kg minimum.

### F.5.e. Fork Lift Operation

The truck must be capable of lifting more than 7 000 kg. Lifting and lowering must be carried out slowly, smoothly and in a controlled fashion.

**Driving must be carried out at slow speed.**

## **G. Key Points for a BioSpec® System with B-C 70/30 USR Magnet**

### **Site Preparation**

The examination room requires an interior ceiling height of minimum 278 cm.

The suggested basic area is approx. 4.40 x 3.60 m.

The floor under the magnet must be capable of handling 6.8 tons or approx. 2957 kg/m<sup>2</sup>.

The magnet is positioned over a surface area of 184 x 122 cm. The magnet stands on four pedestals.

The transport route of the magnet to the site should be min. 250 cm x 260 cm (w x h) and even, without irregularities. Narrow places such as wall openings should not be under 150 cm x 250 cm (w x h).

### **Seismic Vibrations, Magnet Protection**

It must be ensured that the floating floor surrounding the magnet has not direct contact to the magnet base. The magnet base must be fixed to the building construction to avoid the influence of the footfall sound to the magnet. In the frequency range between 3 and 40 Hz the seismic vibrations should not exceed accelerations of 60 µg.

### **Exhaust System of the Magnet (Quench tube or cylinder):**

The magnet is charged with cryogenic liquids (max. 1000 l). Cryogenic liquid gases evaporate with an increase in volume 700 times greater than that of the liquid state. This necessitates the installation of a quench system.

### **The Security Zone of the Magnet:**

The 0.5 mT line in an axial direction is 3.3 m and in a radial direction is 2.2 m from the magnet center. This area must be clearly marked and must be free of large moving ferromagnetic objects such as elevators, etc. as well as the public thorough-fares restricted to individuals without heart pacemakers.

### **Emergency Room, Emergency Plan:**

A room must be defined and equipped as emergency room (this room may be used for other purposes as well).

The user of an MR-system has the obligation to draw up an emergency plan for the security and cleaning personnel as well as the responsible fire brigade.

### **Supply the Magnet with Cryogen Gases:**

Under normal functioning conditions refill time is 90 days approx. 280 liters respectively every 365 days 450 liters helium (dependent upon losses during transfer). Usually the cryogen is supplied in transportation dewars and stored for several days. Special precautions must be taken in the storage room.

**BRUKER MEDICAL GMBH**