

Exhaust Filter

DS-NW25 949-9392

MANUALE DI ISTRUZIONI

INSTRUCTION MANUAL

Exhaust Filter



VARIAN



vacuum technologies

Dear Customer,

Thank you for purchasing a VARIAN vacuum product. At VARIAN Vacuum Technologies we make every effort to ensure that you will be satisfied with the product and/or service you have purchased.

As part of our Continuous Improvement effort, we ask that you report to us any problem you may have had with the purchase or operation of our product. On the back side you find a Corrective Action Request form that you may fill out in the first part and return to us.

This form is intended to supplement normal lines of communications and to resolve problems that existing systems are not addressing in an adequate or timely manner.

Upon receipt of your Corrective Action Request we will determine the Root Cause of the problem and take the necessary actions to eliminate it. You will be contacted by one of our employees who will review the problem with you and update you, with the second part of the same form, on our actions.

Your business is very important to us. Please, take the time and let us know how we can improve.

Sincerely,

Sergio PIRAS

*Vice President and General Manager
VARIAN Vacuum Technologies*

Note: Fax or mail the Customer Request for Action (see backside page) to VARIAN Vacuum Technologies (Torino) - Quality Assurance or to your nearest VARIAN representative for onward transmission to the same address.

CUSTOMER REQUEST FOR CORRECTIVE / PREVENTIVE / IMPROVEMENT ACTION

TO : VARIAN VACUUM TECHNOLOGIES TORINO - QUALITY ASSURANCE

FAX N° : XXXX - 011 - 9979350

ADDRESS: VARIAN S.p.A. - Via F.lli Varian, 54 - 10040 Leinì (Torino) - Italy

E-MAIL : marco.marzio@varianinc.com

| NAME | COMPANY | FUNCTION |
|-------|---------|----------|
| _____ | _____ | _____ |

ADDRESS : _____

TEL. N° : _____ FAX N° : _____

E-MAIL : _____

PROBLEM / SUGGESTION :

REFERENCE INFORMATION (model n°, serial n°, ordering information, time to failure after installation, etc.) :

DATE _____

| | |
|---|--------------|
| CORRECTIVE ACTION PLAN / ACTUATION (by VARIAN VTT) | LOG N° _____ |
| _____ | |
| _____ | |
| _____ | |
| _____ | |
| _____ | |

XXXX = Code for dialing Italy from your country (es. 01139 from USA; 00139 from Japan, etc.)



| | |
|--|---|
| ISTRUZIONI PER L'USO | 1 |
| DESCRIZIONE DEL FILTRO DISOLIATORE | 1 |
| CARATTERISTICHE TECNICHE | 1 |
| DIMENSIONI DI INGOMBRO | 1 |
| FUNZIONAMENTO | 1 |
| INSTALLAZIONE DEL FILTRO DISOLIATORE | 2 |
| MANUTENZIONE | 2 |
| Drenaggio dell'Olio..... | 2 |
| Cambio della Cartuccia..... | 2 |
| PARTI DI RICAMBIO ED ACCESSORI | 2 |

| | |
|---|---|
| INSTRUCTIONS FOR USE | 3 |
| DESCRIPTION OF THE EXHAUST FILTER..... | 3 |
| TECHNICAL SPECIFICATION | 3 |
| OUTLINE DRAWING | 3 |
| OPERATION | 3 |
| EXHAUST FILTER INSTALLATION | 4 |
| MAINTENANCE | 4 |
| Oil Drainage | 4 |
| Cartridge Changing..... | 4 |
| REPLACEMENT PARTS AND ACCESSORIES | 4 |

DESCRIZIONE DEL FILTRO DISOLIATORE

Il filtro di intrappolamento olio NW 25 utilizza cartucce disolianti ad alta efficienza ed ha lo scopo principale di purificare i gas di scarico dagli aerosol di olio e di eventuali altri liquidi.



PERICOLO!

Sostanze allo stato gassoso e di vapore non vengono trattenute dal filtro per cui eventuali gas tossici provenienti dalla pompa devono essere smaltiti allo scarico del filtro in accordo alle norme generali per la protezione contro gas velenosi.

CARATTERISTICHE TECNICHE

La seguente tabella dettaglia le principali caratteristiche del filtro disoliatore.

| | DS NW25 |
|---|--------------------------------|
| Massimo flusso a 1 bar e 20 °C [Nm ³ /h] | 90 |
| Caduta di pressione [mbar] | 150 |
| Massima pressione permessa [bar] | 2.0 |
| Flangia di aspirazione/ scarico | 25 KF |
| Pompe su cui montare il filtro | DS 102 / 202 / 302 / 402 / 602 |

DIMENSIONI DI INGOMBRO

La figura seguente mostra le dimensioni di ingombro del filtro disoliatore (le dimensioni sono in pollici [mm]).

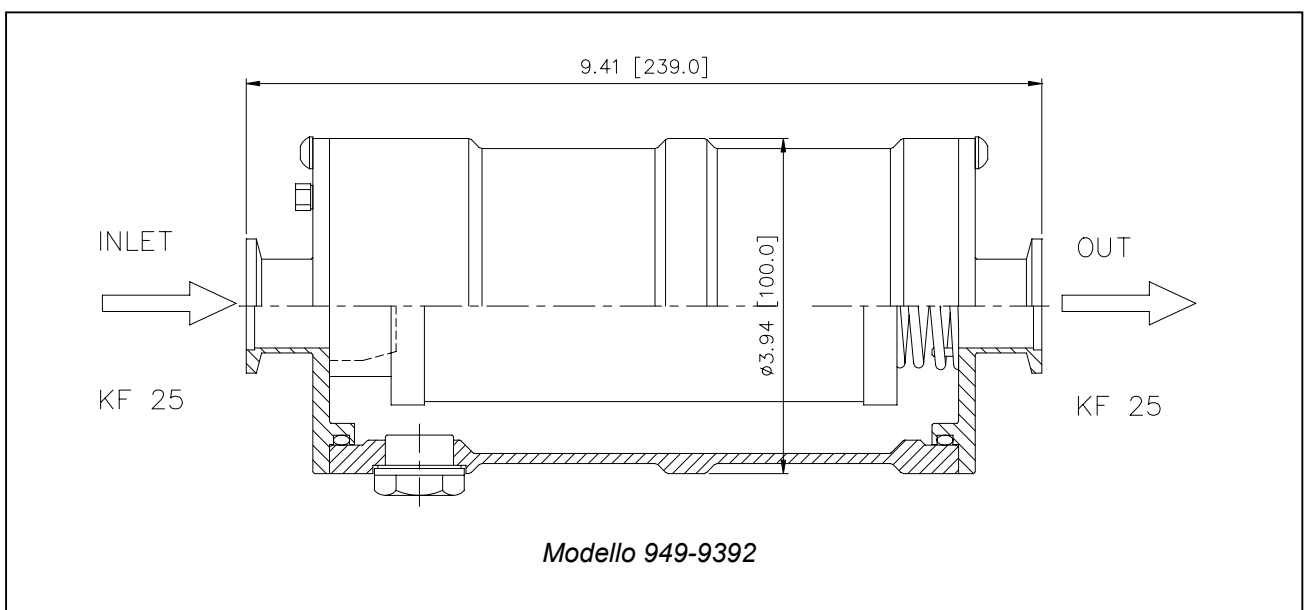

FUNZIONAMENTO

Per questa descrizione, fare riferimento alla figura seguente.

Il gas in uscita dalla pompa percorre il condotto (1), attraversa la cartuccia disoliante (2) ed esce dalla camera (3) circostante.

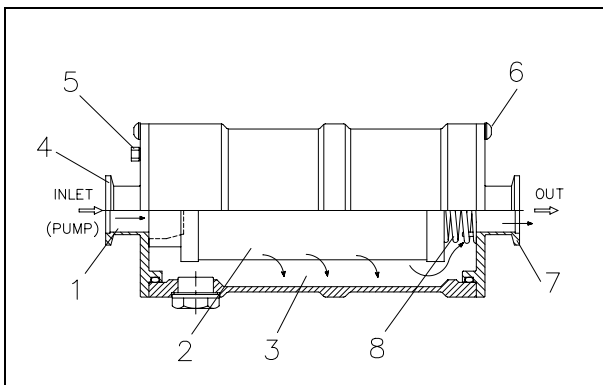

Le nebbie di olio sono trattenute dalla cartuccia, dove si aggregano sotto forma di gocce. Queste, per gravità, si depositano sul fondo del carter.

La cartuccia ha pure la capacità di trattenere particelle solide trascinate dal gas. Queste particelle sono la causa principale di intasamento della cartuccia. Per evitare che la pressione a monte dell'elemento filtrante raggiunga valori tali da compromettere il corretto funzionamento della pompa, è previsto un dispositivo di sovrappressione che interviene quando la pressione raggiunge il valore di 1 bar.

Quando la cartuccia è intasata ed il sistema di sicurezza si è innescato, le nebbie di olio vengono trascinate dal flusso dei gas direttamente dalla pompa all'ambiente esterno.

E' buona norma, prima di giungere al completo intasamento della cartuccia, sostituire la cartuccia a intervalli di tempo regolari, dipendenti dal tipo di applicazione della pompa.

INSTALLAZIONE DEL FILTRO DISOLIATORE

Il filtro disoliatore si monta sulla pompa unendo la flangia (4) (vedere la figura precedente) mediante collare di serraggio e anello di centraggio alla flangia di scarico della pompa.

Il filtro viene fornito montato come mostrato in figura.

MANUTENZIONE**Drenaggio dell'Olio**

L'olio che si accumula nel carter deve essere rimosso prima che bagni la superficie esterna della cartuccia disoliante e ne riduca l'efficienza.

L'oblò posto su un lato del carter consente di tenere sotto controllo il livello dell'olio.

Per effettuare l'operazione di drenaggio occorre svitare il tappo (5).

Cambio della Cartuccia

La cartuccia disoliante ha un tempo limitato di vita, che dipende dal tipo di applicazione. L'intasamento della cartuccia fa entrare in funzione il dispositivo di by-pass che invia i gas direttamente dalla pompa all'ambiente esterno prima che raggiungano pericolose sovrappressioni per la pompa.

In questo caso i fumi d'olio si diffondono nell'ambiente esterno indicando l'avvenuto intasamento della cartuccia stessa e, per evitare l'inquinamento dell'ambiente, si consiglia di sostituire la cartuccia.

Per sostituire la cartuccia occorre seguire i seguenti passi:

1. Svitare le quattro viti (6).

**PERICOLO!**

Avere l'accortezza di trattenerne i due elementi collegati affinché questi non vengano scagliati via a causa della compressione della molla.

2. Rimuovere la cartuccia (2) e sostituirla con quella di ricambio.
3. Accostare la testata (7) al tubo facendo attenzione che la molla (8) non esca dal proprio alloggiamento e che prema la cartuccia contro la sua sede.
4. Avvitare le quattro viti (6).

PARTI DI RICAMBIO ED ACCESSORI

Per avere le giuste parti di ricambio, occorre indicare nell'ordine il tipo di filtro ed il suo numero di modello (indicato sulla sua etichetta).

Come ricambio è disponibile un kit che contiene le guarnizioni del filtro ed il filtro stesso, con la seguente denominazione:

- DS Exhaust Filter Kit NW 25 (P/N 949-9342)

DESCRIPTION OF THE EXHAUST FILTER

The oil Exhaust Filter NW25 uses high efficiency oil separating cartridge. Its function is to purify the exhaust gas from oil or other liquid aerosol.



Gases and vapors are not filtered, so toxic gases from the pump must be disposed according to the general disposition about toxic gases.

| | |
|---|--------------------------------|
| | DS NW25 |
| Max. flux at 1 bar and 20 °C [Nm ³ /h] | 90 |
| Pressure drop [mbar] | 150 |
| Maximum allowed pressure [bar] | 2.0 |
| Inlet/outlet flange | 25 KF |
| Applicable pumps | DS 102 / 202 / 302 / 402 / 602 |

TECHNICAL SPECIFICATION

The following table details the main technical specifications of the Exhaust Filter.

OUTLINE DRAWING

The following figure shows the outline drawing for the Exhaust Filter (the dimensions are inches [mm]).

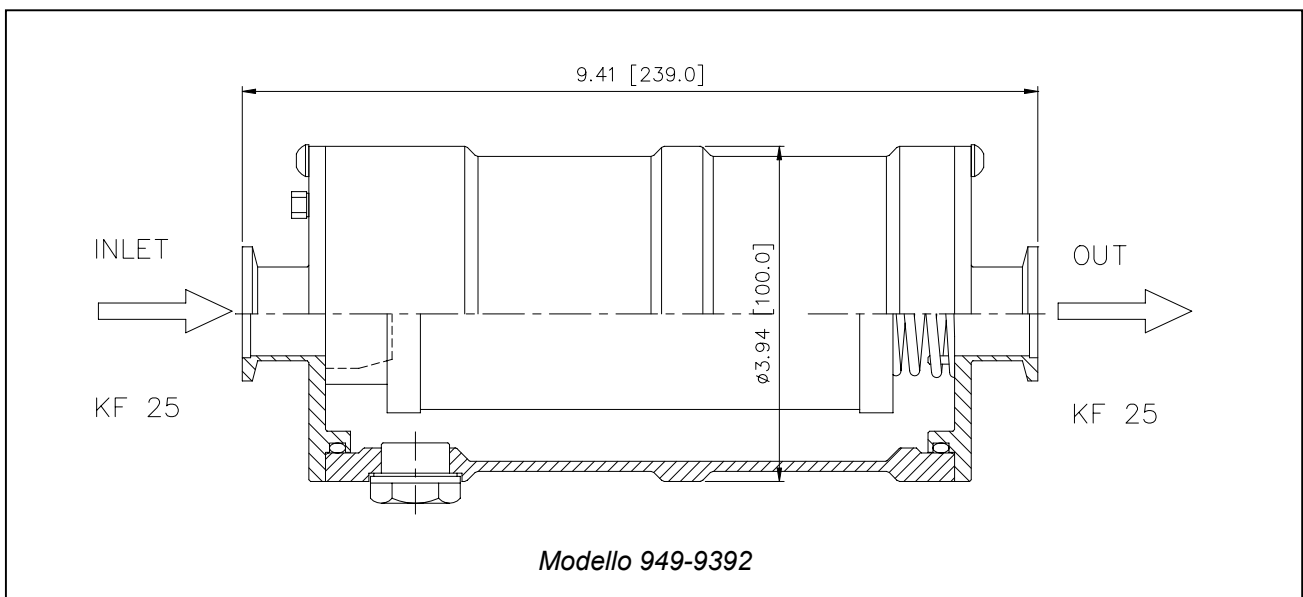

OPERATION

For the following description refer to the following figure.

The output gas from the pump flows through the duct (1), passes the cartridge (2) and exits from the surrounding chamber (3).

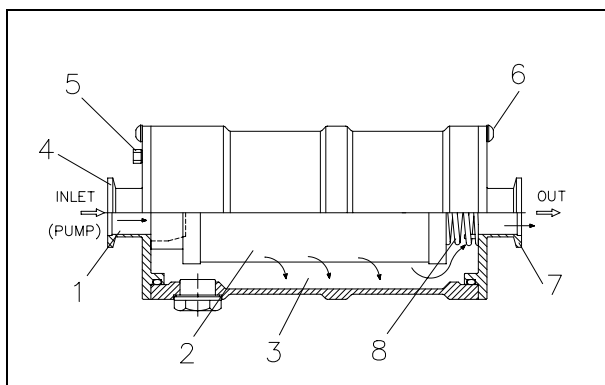

The oil mist is filtered by the cartridge where it transforms into drops. The drops deposit on the carter bottom for the gravity effect.

The cartridge also filters the solid particles from the gas. These particles are the main cause of the cartridge clog.

To avoid that the pressure before the filtering element increases so that the pump does not work properly, an overpressure device is provided that intervenes when the pressure reaches the 1 bar value.

When the cartridge is obstructed and the security system is operating, the oil mist is dragged by the gas flux from the pump directly to the external ambient.

Before the cartridge is completely obstructed, it is advisable to change it on a regular basis according to the pump application.

EXHAUST FILTER INSTALLATION

The Exhaust Filter is installed on the pump connecting the flange (4) (see the preceding figure) to the outlet flange of the pump by means of a clamping collar and centering ring.

The filter is factory assembled as shown in the figure.

MAINTENANCE

Oil Drainage

The oil on the carter bottom must be periodically removed before it reaches the external surface of the cartridge so that its efficiency is reduced.

The window on a side of the carter allows to check the oil level.

To drain the oil it is necessary to unscrew the plug (5).

Cartridge Changing

The cartridge has a limited life time that depends on the pump application. The cartridge clogging activates the by-pass device so that the gases from the pump are directly sent to the external ambient to avoid dangerous pump overpressures.

In this case the oil mist are diffused into the atmosphere indicating that the cartridge is obstructed and, to avoid the ambient pollution, it is advisable to change the cartridge.

To change the cartridge you must execute the following steps:

1. Unscrew the four screws (6).



WARNING!

Take care to keep in position the two elements so that they are not thrown away by the spring compression.

2. Remove the cartridge (2) and insert the new one.
3. Place the head (7) close to the pipe taking care that the spring (8) do not exit from its seat and that it presses the cartridge in its position.
4. Screw the four screws (6).

REPLACEMENT PARTS AND ACCESSORIES

To obtain the correct replacement parts, the order must contain the filter type and its model number (it is indicated onto the filter label)

As replacement parts ordering, a filter kit, that contains the filter itself and the relevant gaskets, is available, with the following description:

- DS Exhaust Filter Kit NW 25 (P/N 949-9342)



Request for Return



1. A Return Authorization Number (RA#) **WILL NOT** be issued until this Request for Return is completely filled out, signed and returned to Varian Customer Service.
2. Return shipments shall be made in compliance with local and international **Shipping Regulations** (IATA, DOT, UN).
3. The customer is expected to take the following actions to ensure the **Safety** of workers at Varian: (a) Drain any oils or other liquids, (b) Purge or flush all gasses, (c) Wipe off any excess residues in or on the equipment, (d) Package the equipment to prevent shipping damage, (for Advance Exchanges please use packing material from replacement unit).
4. Make sure the shipping documents clearly show the RA# and then return the package to the Varian location nearest you.

North and South America

Varian Vacuum Technologies
 121 Hartwell Ave
 Lexington, MA 02421
 Phone : +1 781 8617200
 Fax: +1 781 8609252

Europe and Middle East

Varian SpA
 Via Flli Varian 54
 10040 Leini (TO) – ITALY
 Phone: +39 011 9979111
 Fax: +39 011 9979330

Asia and ROW

Varian Vacuum Technologies
 Local Office

CUSTOMER INFORMATION

| | |
|--|--|
| Company name: | |
| Contact person: Name: | Tel: |
| Fax: | E-Mail: |
| Ship Method: | Shipping Collect #: P.O.#: |
| <i>Europe only:</i> VAT reg. Number: | <i>USA only:</i> <input type="checkbox"/> Taxable <input type="checkbox"/> Non-taxable |
| Customer Ship To: | Customer Bill To: |
| | |
| | |

PRODUCT IDENTIFICATION

| Product Description | Varian P/N | Varian S/N | Purchase Reference |
|---------------------|------------|------------|--------------------|
| | | | |
| | | | |
| | | | |

TYPE OF RETURN (check appropriate box)

| | | | | |
|--|---|--|--|--|
| <input type="checkbox"/> Paid Exchange | <input type="checkbox"/> Paid Repair | <input type="checkbox"/> Warranty Exchange | <input type="checkbox"/> Warranty Repair | <input type="checkbox"/> Loaner Return |
| <input type="checkbox"/> Credit | <input type="checkbox"/> Shipping Error | <input type="checkbox"/> Evaluation Return | <input type="checkbox"/> Calibration | <input type="checkbox"/> Other |

HEALTH and SAFETY CERTIFICATION

Varian Vacuum Technologies **CAN NOT ACCEPT** any equipment which contains **BIOLOGICAL HAZARDS** or **RADIOACTIVITY**. Call Varian Customer Service to discuss alternatives if this requirement presents a problem.

The equipment listed above (check one):

HAS NOT been exposed to any toxic or hazardous materials

OR

HAS been exposed to any toxic or hazardous materials. In case of this selection, check boxes for any materials that equipment was exposed to, check all categories that apply:

- Toxic Corrosive Reactive Flammable Explosive Biological Radioactive

List all toxic or hazardous materials. Include product name, chemical name and chemical symbol or formula.

.....

Print Name: Customer Authorized Signature:

Print Title: Date:/...../.....

NOTE: If a product is received at Varian which is contaminated with a toxic or hazardous material that was not disclosed, **the customer will be held responsible** for all costs incurred to ensure the safe handling of the product, and **is liable** for any harm or injury to Varian employees as well as to any third party occurring as a result of exposure to toxic or hazardous materials present in the product.

Do not write below this line

Notification (RA)#: Customer ID#: Equipment #:

FAILURE REPORT

TURBO PUMPS and TURBOCONTROLLERS

| | | | |
|---|--|---|---|
| <input type="checkbox"/> Does not start <input type="checkbox"/> Does not spin freely <input type="checkbox"/> Does not reach full speed <input type="checkbox"/> Mechanical Contact <input type="checkbox"/> Cooling defective | <input type="checkbox"/> Noise <input type="checkbox"/> Vibrations <input type="checkbox"/> Leak <input type="checkbox"/> Overtemperature | POSITION <input type="checkbox"/> Vertical <input type="checkbox"/> Horizontal <input type="checkbox"/> Upside-down <input type="checkbox"/> Other: | PARAMETERS Power: Rotational Speed: Current: Inlet Pressure: Temp 1: Foreline Pressure: Temp 2: Purge flow: <hr/> OPERATION TIME: |
| TURBOCONTROLLER ERROR MESSAGE: | | | |

ION PUMPS/CONTROLLERS

| | |
|--|---|
| <input type="checkbox"/> Bad feedthrough <input type="checkbox"/> Vacuum leak <input type="checkbox"/> Error code on display | <input type="checkbox"/> Poor vacuum <input type="checkbox"/> High voltage problem <input type="checkbox"/> Other |
| Customer application: | |

VALVES/COMPONENTS

| | |
|---|--|
| <input type="checkbox"/> Main seal leak <input type="checkbox"/> Solenoid failure <input type="checkbox"/> Damaged sealing area | <input type="checkbox"/> Bellows leak <input type="checkbox"/> Damaged flange <input type="checkbox"/> Other |
| Customer application: | |

LEAK DETECTORS

| | |
|--|---|
| <input type="checkbox"/> Cannot calibrate <input type="checkbox"/> Vacuum system unstable <input type="checkbox"/> Failed to start | <input type="checkbox"/> No zero/high background <input type="checkbox"/> Cannot reach test mode <input type="checkbox"/> Other |
| Customer application: | |

INSTRUMENTS

| | |
|---|--|
| <input type="checkbox"/> Gauge tube not working <input type="checkbox"/> Communication failure <input type="checkbox"/> Error code on display | <input type="checkbox"/> Display problem <input type="checkbox"/> Degas not working <input type="checkbox"/> Other |
| Customer application: | |

PRIMARY PUMPS

| | |
|--|---|
| <input type="checkbox"/> Pump doesn't start <input type="checkbox"/> Doesn't reach vacuum <input type="checkbox"/> Pump seized | <input type="checkbox"/> Noisy pump (describe) <input type="checkbox"/> Over temperature <input type="checkbox"/> Other |
| Customer application: | |

DIFFUSION PUMPS

| | |
|--|---|
| <input type="checkbox"/> Heater failure <input type="checkbox"/> Doesn't reach vacuum <input type="checkbox"/> Vacuum leak | <input type="checkbox"/> Electrical problem <input type="checkbox"/> Cooling coil damage <input type="checkbox"/> Other |
| Customer application: | |

FAILURE DESCRIPTION

(Please describe in detail the nature of the malfunction to assist us in performing failure analysis):

NOTA: Su richiesta questo documento è disponibile anche in Tedesco, Italiano e Francese.
REMARQUE : Sur demande ce document est également disponible en allemand, italien et français.
HINWEIS: Auf Anfrage ist diese Unterlage auch auf Deutsch, Italienisch und Französisch erhältlich.

Sales and Service Offices

Argentina

Varian Argentina Ltd.

Sucursal Argentina
Av. Ricardo Balbin 2316
1428 Buenos Aires
Argentina
Tel: (54) 1 783 5306
Fax: (54) 1 786 5172

Benelux

Varian Vacuum Technologies

Rijksstraatweg 269 H,
3956 CP Leersum
The Netherlands
Tel: (31) 343 469910
Fax: (31) 343 469961

Brazil

Varian Industria e Comercio Ltda.

Avenida Dr. Cardoso de Mello 1644
Vila Olimpia
Sao Paulo 04548 005
Brazil
Tel: (55) 11 3845 0444
Fax: (55) 11 3845 9350

Canada

Central coordination through:

Varian Vacuum Technologies
121 Hartwell Avenue
Lexington, MA 02421
USA
Tel: (781) 861 7200
Fax: (781) 860 5437
Toll Free # 1 (800) 882 7426

China

Varian Technologies - Beijing

Room 1201, Jinyu Mansion
No. 129A, Xuanwumen Xidajie
Xicheng District
Beijing 100031 P.R. China
Tel: (86) 10 6641 1530
Fax: (86) 10 6641 1534

France and Wallonie

Varian s.a.

7 avenue des Tropiques
Z.A. de Courtaboeuf - B.P. 12
Les Ulis cedex (Orsay) 91941
France
Tel: (33) 1 69 86 38 13
Fax: (33) 1 69 28 23 08

Germany and Austria

Varian Deutschland GmbH

Alsfelder Strasse 6
Postfach 11 14 35
64289 Darmstadt
Germany
Tel: (49) 6151 703 353
Fax: (49) 6151 703 302

India

Varian India PVT LTD

101-108, 1st Floor
1010 Competent House
7, Nangal Raya Business Centre
New Delhi 110 046
India
Tel: (91) 11 5548444
Fax: (91) 11 5548445

Italy

Varian Vacuum Technologies

via F.lli Varian 54
10040 Leini, (Torino)
Italy
Tel: (39) 011 997 9 111
Fax: (39) 011 997 9 350

Japan

Varian Vacuum Technologies

Sumitomo Shibaura Building, 8th Floor
4-16-36 Shibaura
Minato-ku, Tokyo 108
Japan
Tel: (81) 3 5232 1253
Fax: (81) 3 5232 1263

Korea

Varian Technologies Korea, Ltd

Shinsa 2nd Bldg. 2F
966-5 Daechi-dong
Kangnam-gu, Seoul
Korea 135-280
Tel: (82) 2 3452 2452
Fax: (82) 2 3452 2451

Mexico

Varian, S. de R.L. de C.V.

Concepcion Beistegui No 109
Col Del Valle
C.P. 03100
Mexico, D.F.
Tel: (52) 5 523 9465
Fax: (52) 5 523 9472

Taiwan

Varian Technologies Asia Ltd.

14F-6, No.77, Hsin Tai Wu Rd., Sec. 1
Hsi chih, Taipei Hsien
Taiwan, R.O.C.
Tel: (886) 2 2698 9555
Fax: (886) 2 2698 9678

UK and Ireland

Varian Ltd.

28 Manor Road
Walton-On-Thames
Surrey KT 12 2QF
England
Tel: (44) 1932 89 8000
Fax: (44) 1932 22 8769

United States

Varian Vacuum Technologies

121 Hartwell Avenue
Lexington, MA 02421
USA
Tel: (781) 861 7200
Fax: (781) 860 5437

Other Countries

Varian Vacuum Technologies

via F.lli Varian 54
10040 Leini, (Torino)
Italy
Tel: (39) 011 997 9 111
Fax: (39) 011 997 9 350

Customer Support & Service:

North America

Tel: 1 (800) 882 7426 (toll-free)
vtt.technical.support@varianinc.com

Europe

Tel: 00 (800) 234 234 00 (toll-free)
vtt.technical.support@varianinc.com

Japan

Tel: (81) 3 5232 1253 (dedicated line)
vtj.technical.support@varianinc.com

Korea

Tel: (82) 2 3452 2452 (dedicated line)
vtk.technical.support@varianinc.com

Taiwan

Tel: 0 (800) 051 342 (toll-free)
vtw.technical.support@varianinc.com

Worldwide Web Site, Catalog and Order On-line:

www.varianinc.com

Representative in most countries

